



Disclaimer

This user manual is provided as a free service by FixYourDLP.com. FixYourDLP is in no way responsible for the content of this manual, nor do we guarantee its accuracy. FixYourDLP does not make any claim of copyright and all copyrights remain the property of their respective owners.

About FixYourDLP.com

FixYourDLP.com (<http://www.fixyourdpl.com>) is the World's #1 resource for media product news, reviews, do-it-yourself guides, and manuals.

Informational Blog: <http://www.fixyourdpl.com>

Video Guides: <http://www.fixyourdpl.com/guides>

User Forums: <http://www.fixyourdpl.com/forum>

FixYourDLP's Fight Against Counterfeit Lamps:

<http://www.fixyourdpl.com/counterfeits>

Sponsors:

RecycleYourLamp.org – Free lamp recycling services for used lamps:

<http://www.recycleyourlamp.org>

Lamp Research - The trusted 3rd party lamp research company:

<http://www.lampresearch.com>

Discount-Merchant.com – The worlds largest lamp distributor:

<http://www.discount-merchant.com>



FixYourDLP.com

Sponsored by 

SANYO

Portable LCD Data-Grade Color Projector

MODEL PLC-550M

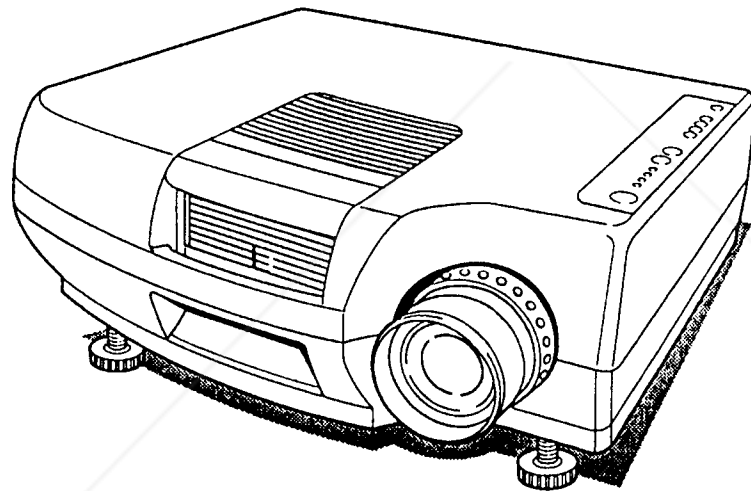

**Owner's
Manual**



FixYourDLP.com

Sponsored by DM

Discount-Merchant.com (800) 281-8860

THE TRUSTED SOURCE FOR PROJECTOR LAMPS AND ACCESSORIES

INFORMATION TO THE USER

NOTE: This equipment has been tested and found to comply with the limits for a Class A digital device, pursuant to Part 15 of the FCC Rules. These limits are designed to provide reasonable protection against harmful interference when the equipment is operated in a commercial environment. This equipment generates, uses, and can radiate radio frequency energy and, if not installed and used in accordance with the instruction manual, may cause harmful interference to radio communications. Operation of this equipment in a residential area is likely to cause harmful interference in which case the user will be required to correct the interference at his own expense.

TO THE OWNER

As the owner of a new Portable LCD Data-Grade Color Projector, you are probably eager to try out your new projector. Before you do, we suggest that you spend a little time reading this manual to familiarize yourself with the operating procedures, so that you will receive maximum enjoyment from the many features included on your new projector.

This owner's manual will acquaint you with your projector's features. Reading it will help us too. Through the years, we have found that many service requests were not caused by problems with our projectors. They were caused by problems that could have been prevented, if the owner had followed the instructions in the manual.

You can often correct operating problems yourself. If your projector fails to work properly, locate the operating problem in the Helpful Hints Chart on page 21 and try the solutions marked for each problem.

SAFETY PRECAUTIONS

WARNING:

TO REDUCE THE RISK OF FIRE OR ELECTRIC SHOCK, DO NOT EXPOSE THIS APPLIANCE TO RAIN OR MOISTURE.

The new Portable LCD Data-Grade Color Projector has a grounding-type AC line plug. This is a safety feature to be sure that the plug will fit into the power outlet. Do not try to defeat this safety feature.

Intense light source. Do not stare directly into the projection lens as possible eye damage could result. Be especially careful that children do not stare directly into the beam.

If the new Portable LCD Data-Grade Color Projector will not be used for an extended time, unplug the new Portable LCD Data-Grade Color Projector from the power outlet.

READ AND KEEP THIS OWNER'S MANUAL FOR LATER USE.



CAUTION
RISK OF ELECTRIC SHOCK
DO NOT OPEN



CAUTION: TO REDUCE THE RISK OF ELECTRIC SHOCK, DO NOT REMOVE COVER (OR BACK). NO USER-SERVICEABLE PARTS INSIDE. REFER SERVICING TO QUALIFIED SERVICE PERSONNEL.



THIS SYMBOL INDICATES THAT DANGEROUS VOLTAGE CONSTITUTING A RISK OF ELECTRIC SHOCK IS PRESENT WITHIN THIS UNIT.



THIS SYMBOL INDICATES THAT THERE ARE IMPORTANT OPERATING AND MAINTENANCE INSTRUCTIONS IN THE OWNER'S MANUAL WITH THIS UNIT.

IMPORTANT SAFETY INSTRUCTIONS

All the safety and operating instructions should be read before the product is operated.

Read all of the instructions given here and retain them for later use. Unplug this projector from AC power supply before cleaning. Do not use liquid or aerosol cleaners. Use a damp cloth for cleaning.

Do not use attachments not recommended by the manufacturer as they may cause hazards.

Do not place this projector on an unstable cart, stand, or table. The projector may fall, causing serious injury to a child or adult, and serious damage to the projector. Use only with a cart or stand recommended by the manufacturer, or sold with the projector. Wall or shelf mounting should follow the manufacturer's instructions, and should use a mounting kit approved by the manufacturer.

Do not expose this unit to rain or use near water... for example, in a wet basement, near a swimming pool or the like.

Slots and openings in the cabinet and the back or bottom are provided for ventilation, to insure reliable operation of the equipment and to protect it from overheating.

The openings should never be covered with cloth or other material, and the bottom opening should not be blocked by placing the projector on a bed, sofa, rug, or other similar surface. This projector should never be placed near or over a radiator or heat register.

This projector should not be placed in a built-in installation such as a bookcase unless proper ventilation is provided.

This projector should be operated only from the type of power source indicated on the marking label. If you are not sure of the type of power supplied, consult your authorized dealer or local power company.

Do not overload wall outlets and extension cords as this can result in fire or electric shock. Do not allow anything to rest on the power cord. Do not locate this projector where the cord will be abused by persons walking on it.

Never insert objects of any kind into this projector through case slots as they may touch dangerous voltage points or short out parts that could result in a fire or electric shock. Never spill liquid of any kind on the projector.

Do not attempt to service this projector yourself as opening or removing covers may expose you to dangerous voltage or other hazards. Refer all servicing to qualified service personnel.

Unplug this projector from wall outlet and refer servicing to qualified service personnel under the following conditions:

- a. When the power cord or plug is damaged or frayed.
- b. If liquid has been spilled into the projector.
- c. If the projector has been exposed to rain or water.
- d. If the projector does not operate normally by following the operating instructions. Adjust only those controls that are covered by the operating instructions as improper adjustment of other controls may result in damage and will often require extensive work by a qualified technician to restore the projector to normal operation.
- e. If the projector has been dropped or the cabinet has been damaged.
- f. When the projector exhibits a distinct change in performance-this indicates a need for service.

When replacement parts are required, be sure the service technician has used replacement parts specified by the manufacturer that have the same characteristics as the original part. Unauthorized substitutions may result in fire, electric shock, or injury to persons.

Upon completion of any service or repairs to this projector, ask the service technician to perform routine safety checks to determine that the projector is in safe operating condition.

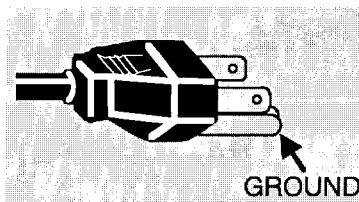

This projector is equipped with a grounding type AC line plug. Should you be unable to insert the plug into the outlet, contact your electrician. Do not defeat the safety purpose of this grounding type plug.

Follow all warnings and instructions marked on the projectors.

For added protection for the projector during a lightning storm, or when it is left unattended and unused for long periods of time, unplug it from the wall outlet. This will prevent damage due to lightning and powerline surges.



An appliance and cart combination should be moved with care. Quick stops, excessive force, and uneven surfaces may cause the appliance and cart combination to overturn.

TABLE OF CONTENTS

	PAGE
DESCRIPTION.....	5
CONNECTING THE PROJECTOR	6-9
SETTING-UP THE PROJECTOR.....	10
OPERATION OF CONTROLS.....	11-12
REMOTE CONTROL UNIT OPERATION.....	13-14
USING THE PROJECTOR	15-17
PICTURE ADJUSTMENTS.....	18-19
AIR FILTER CARE AND CLEANING	20
LAMP REPLACEMENT/TEMPERATURE INDICATORS	20
HELPFUL HINTS-Problems and Solutions.....	21
TECHNICAL SPECIFICATIONS.....	22

POWER REQUIREMENTS

Your projector uses nominal input voltages of 120 VAC. The projector is designed to work with single-phase power systems having a grounded neutral conductor. To reduce the risk of electrical shock, do not plug into any other type of power system. Consult your authorized dealer or service station if you are not sure what type of power is supplied to your building.

Projector side (Female)

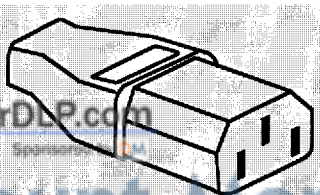

AC outlet side (Male)

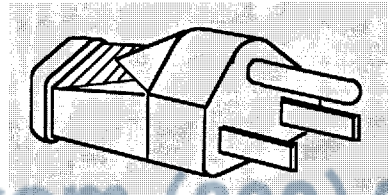

DESCRIPTION

FRONT

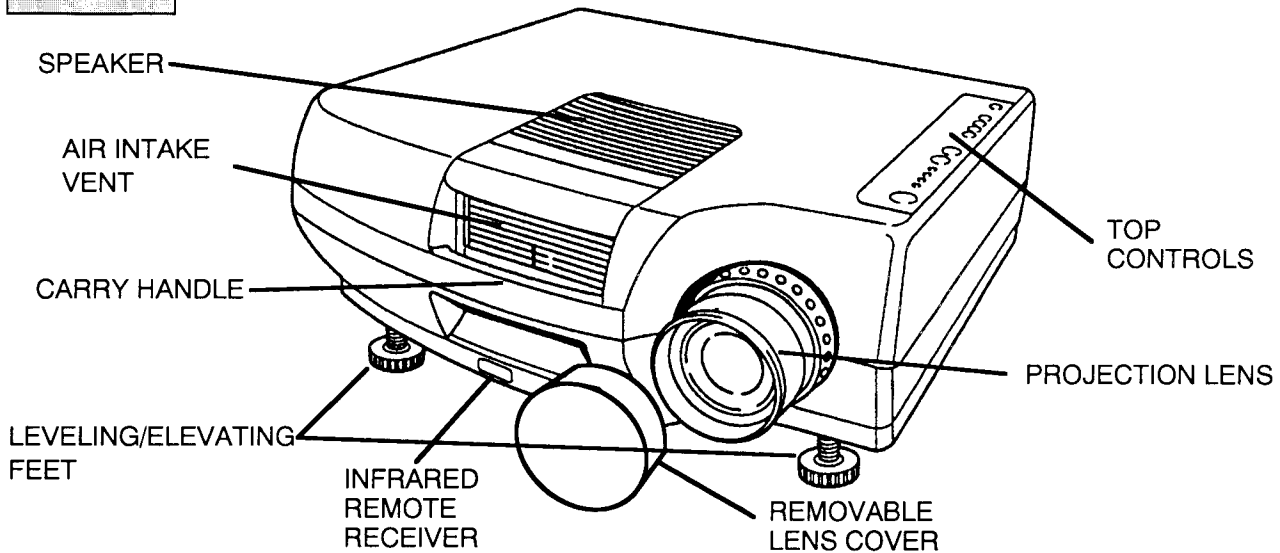

REAR

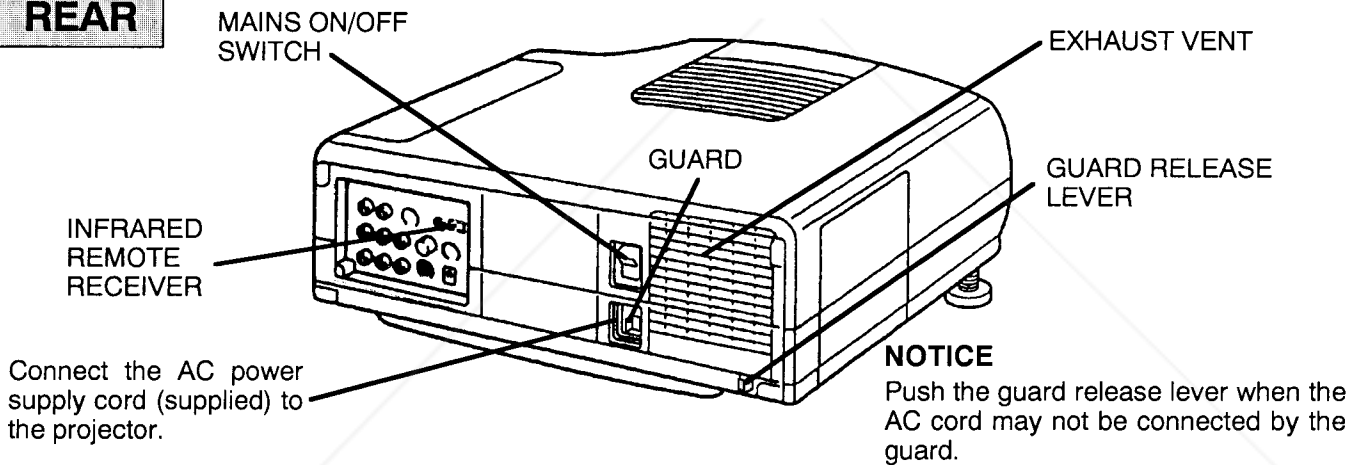

MOVING THE PROJECTOR

Use the carry handle when moving projector.
Replace the lens cover when moving the projector to prevent damage to the lens.

NOTE:

Do not hold the projector by the filter cover when moving.
You risk dropping the projector if the cover comes loose.

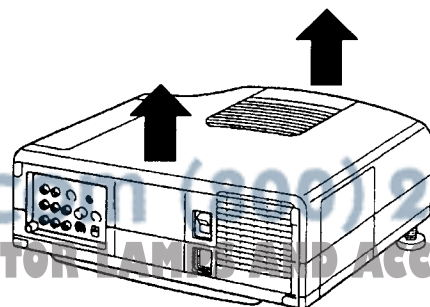
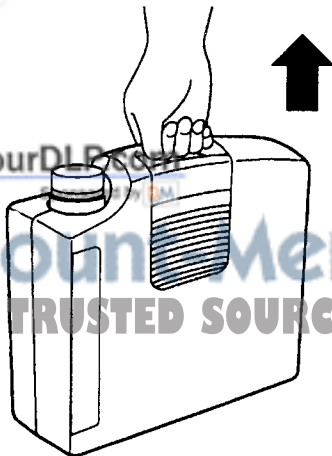

CONNECTING THE PROJECTOR

Your projector is equipped with various audio/video inputs and outputs including Computer HDB15-pin terminals, Monitor HDB15-pin terminals, and S-VHS video .

COMPUTER MODE

This projector is compatible with many different types of personal computers: using the adapter cable provided, it can be connected directly to any VGA and MAC II or compatible computers equipped with FM-TOWNS (640 × 400), FM-TOWNS (640 × 480), PC-9801 (640 × 400), PC-9821 (640 × 400), PC-9821 (640 × 480), AT&T, AX-286/386, GENOA 6000, and VESA VS901001. (adapter cable not provided).

CONNECTING TO THE COMPUTER INPUT HDB15-PIN TERMINAL

Personal computers can be connected to the HDB15-pin terminal on the projector.

- Connect the computer to this terminal using the adapter cable (two type of adapter cables are provided).

WARNING: For projectors, adapter cable provided is designed to reduce RFI (Radio Frequency Interference) emissions. For regulatory compliance reasons, this cable must be used and must not be replaced by any other cable.

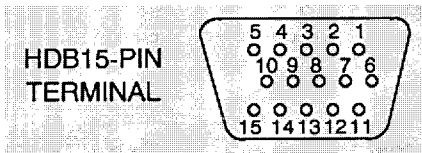

Pin No./Signal

- 1 Red input
- 2 Green input
- 3 Blue input
- 4 Sense 2
- 5 Ground (Horiz. sync.)
- 6 Ground (Red)
- 7 Ground (Green)
- 8 Ground (Blue)

Pin No./Signal

- 9 Non Connect
- 10 Ground (Vert. sync.)
- 11 Sense 0
- 12 Sense 1
- 13 Horiz. sync.
- 14 Vert. sync.
- 15 Reserved

CONNECTING TO THE MONITOR OUTPUT HDB15-PIN TERMINAL

Monitor televisions can be connected to the HDB15-pin terminal on the projector.

- Connect the monitor television to this terminal using the adapter cable (not provided).

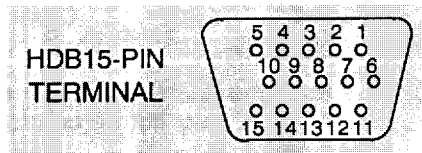

Pin No./Signal

- 1 Red input
- 2 Green input
- 3 Blue input
- 4 Sense 2
- 5 Ground (Horiz. sync.)
- 6 Ground (Red)
- 7 Ground (Green)
- 8 Ground (Blue)

Pin No./Signal

- 9 Non Connect
- 10 Ground (Vert. sync.)
- 11 Sense 0
- 12 Sense 1
- 13 Horiz. sync.
- 14 Vert. sync.
- 15 Reserved

CONNECTING TO THE COMPUTER AUDIO INPUT JACKS

- Connect audio outputs from your computer to these jacks.
- If the audio input of the audio equipment is stereo, be sure to connect the right and left channels to the respective right and left jacks.
- If the audio input of the audio equipment is monaural, connect it to the left jack.

CONNECTING TO THE DIN8 (SERIAL PORT) CONNECTOR

If you control the projector by computer, you must connect a cable from your computer to this connector.

■ SERIAL PORT

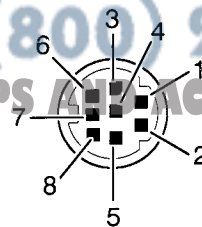

1	RxD
2	ADB
3	MUX232
4	GND
5	MUXTTL
6	TxD
7	—
8	—

CONNECTING THE PROJECTOR TO A COMPUTER

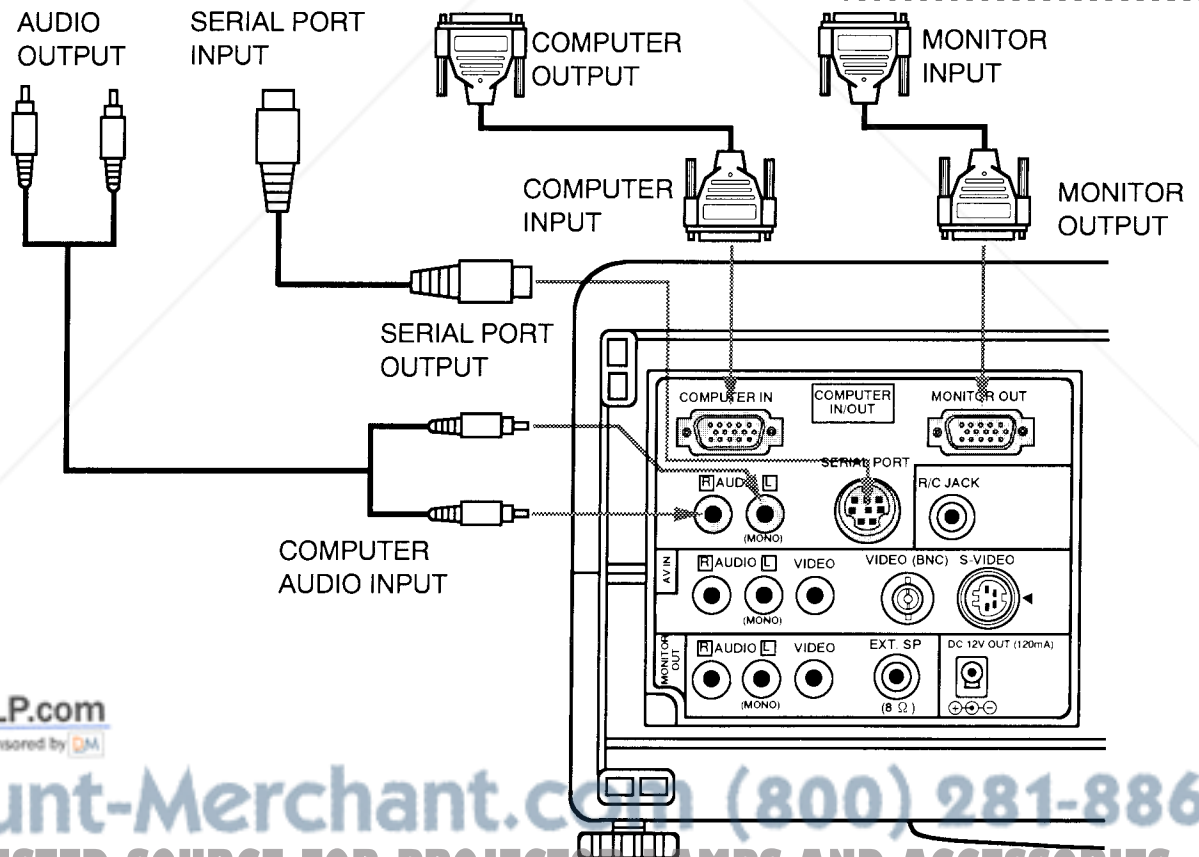
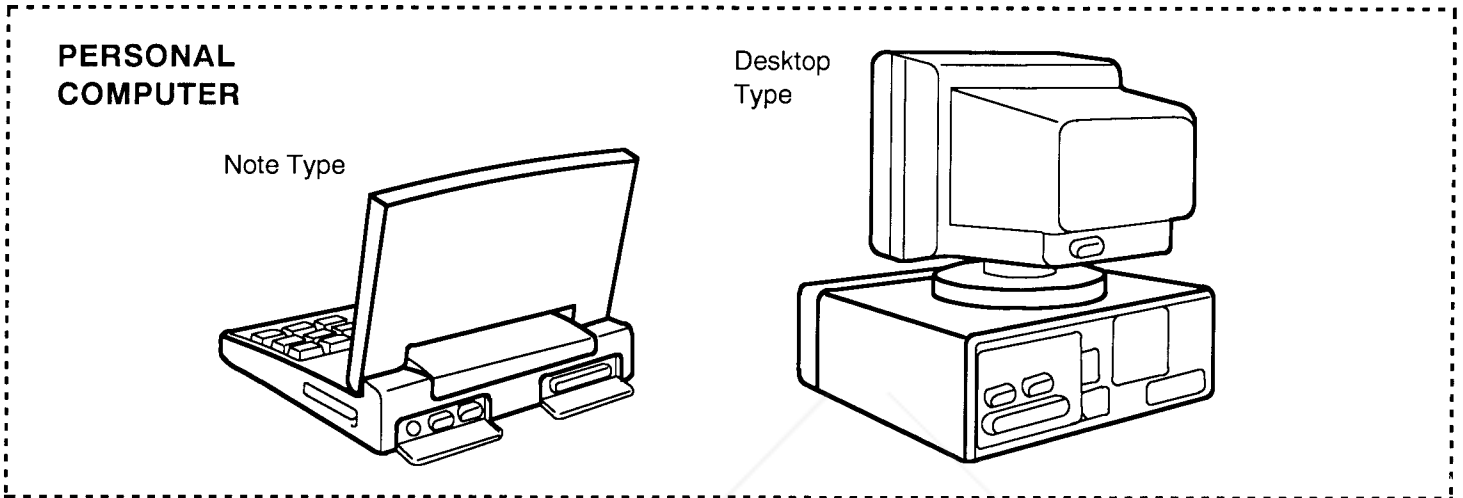
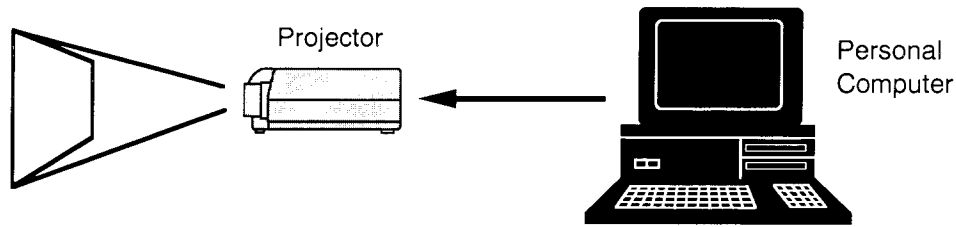

FixYourDLP.com
Sponsored by DM

Discount-Merchant.com (800) 281-8860

THE TRUSTED SOURCE FOR PROJECTOR LAMPS AND ACCESSORIES

NOTE: The hook up should be done as per the above illustration. After hook up, turn on the personal computer and monitor and the POWER(LAMP) ON/OFF button to light the projection lamp. Otherwise, the monitor's image does not appear.

AV MODE

CONNECTING TO THE AV INPUT JACKS

Connect to the video and audio outputs of a VCR, video disc player, video camera, satellite TV tuner or other AV equipment.

- Connect video/audio outputs from external sources to these input jacks.
- If the audio signal from the AV equipment is stereo, be sure to connect the right and left channels to the respective right and left audio input jacks.
- If the external audio signal is monaural, connect it to the left jack.
- Do not connect the video sources to the video input jack (RCA) together with the BNC jack. Use one video input only for video input jack.

S-VHS FORMAT VCR CONNECTION

The AV input includes an extra video input jack marked S-VIDEO to allow connection to an S-VHS format VCR that has separate Y/C video signals. The S-VIDEO jack has priority over the VIDEO (RCA or BNC) jack.

CONNECTING TO THE MONITOR OUTPUT JACKS

These jacks contain the audio/video information that is viewed on the screen.

- Connect video/audio inputs from AV equipment to these output jacks.
- If the audio input of the audio equipment is stereo, be sure to connect the right and left channels to the respective right and left jacks.
- If the audio input of the audio equipment is monaural, connect it to the left jack.
- Whenever the S-VIDEO signal source is viewed on the screen, the video signal available at the MONITOR OUTPUT jack will be in black and white (monochrome).

CONNECTING TO THE EXT. SP. JACK (3.5mm mini type)

This jack contain the audio information that is viewed on the screen. Use to connect a external monaural speaker system when using this jack, turn off the audio from the internal speaker.

CONNECTING TO THE DC 12V SOURCE

Used as a DC source for other equipment such as controllers electric screens.



Discount-Merchant.com (800) 281-8860
THE TRUSTED SOURCE FOR PROJECTOR LAMPS AND ACCESSORIES

HOW TO CONNECT EXTERNAL AV EQUIPMENT

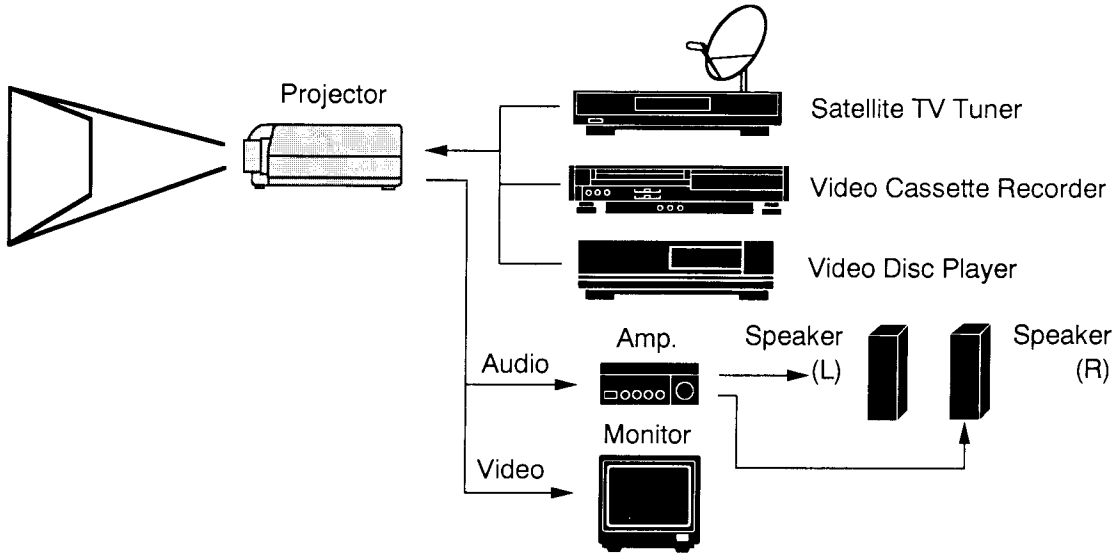

VIDEO EQUIPMENT

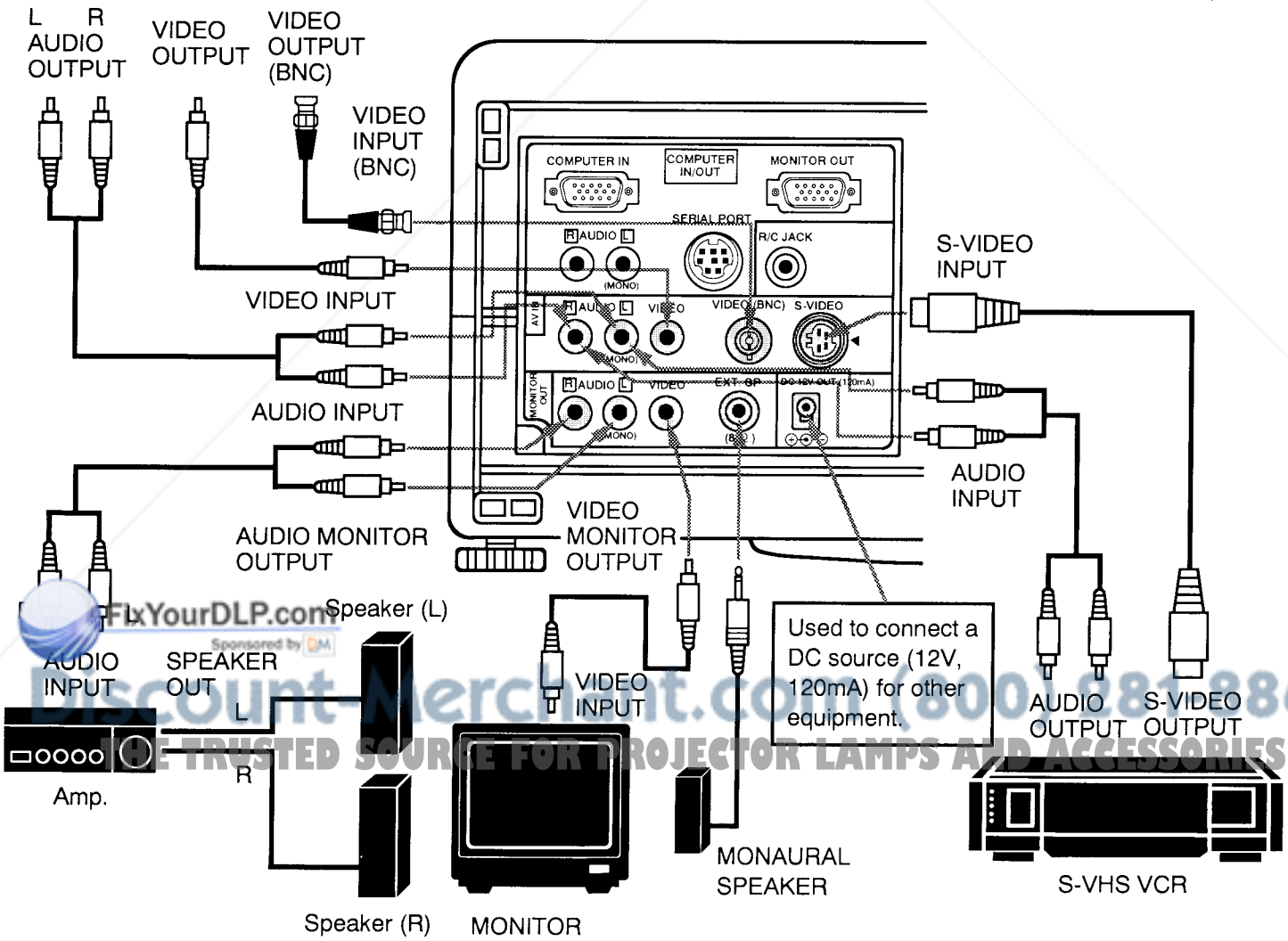
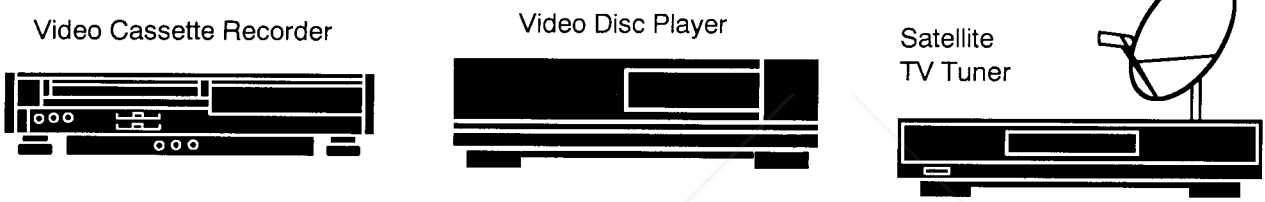

SETTING-UP THE PROJECTOR

POSITIONING:

- This projector is basically designed to project on a flat projection surface.
- This projector can be focused from 4.9' (1.5m) ~ 39.4' (12.0m).
- Use the illustration below as an example when positioning the projector to the screen.

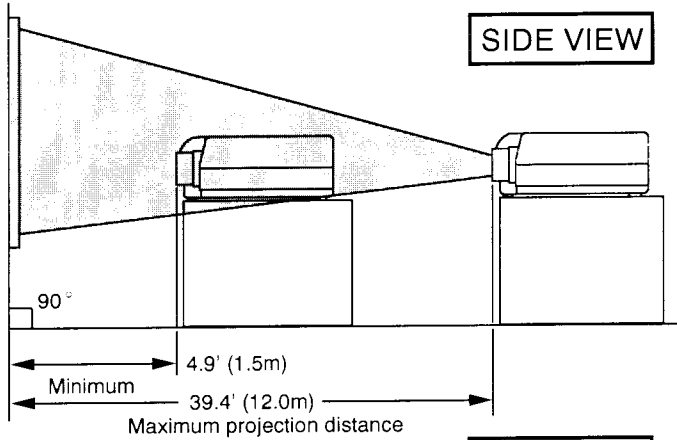

ROOM LIGHT

The projector should ideally be placed in a room with very limited light. Picture quality will be directly affected by lighting conditions.

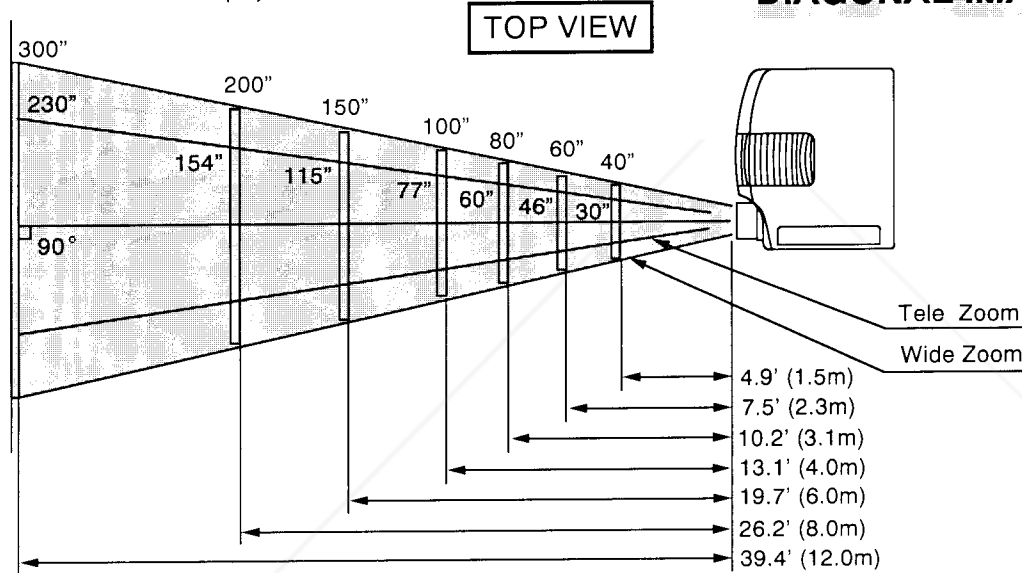

LEVELING AND ELEVATING ADJUSTMENTS

Picture adjustments can be made with the two leveling/elevating feet. Adjustments of 6° up are possible by rotating the feet on the bottom of the projector. Adjust leveling of the projector, by rotating the two (left and right) feet on the bottom of the projector.

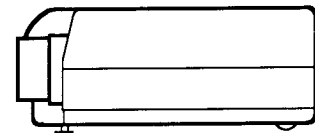

LEVELING/ELEVATING FEET

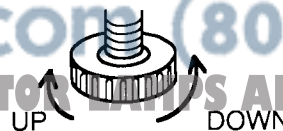
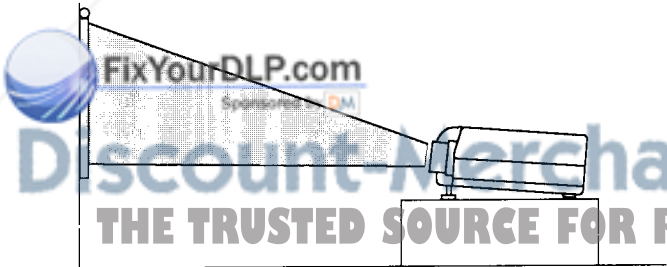

OPERATION OF CONTROLS

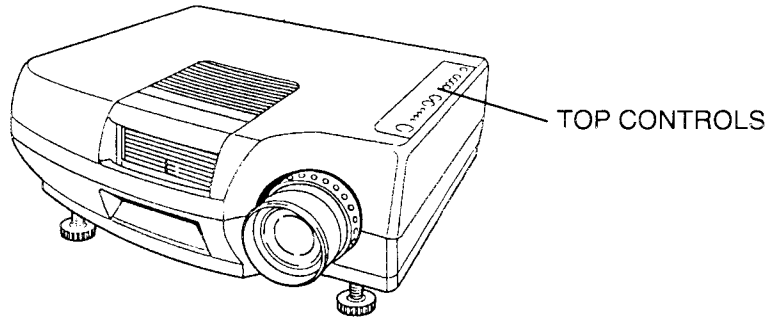

TOP CONTROLS

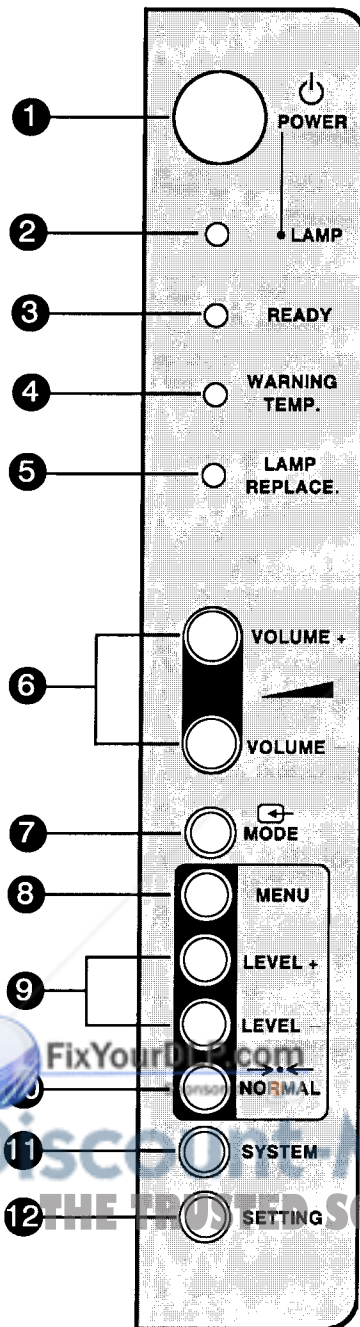

- 1** POWER (LAMP) ON/OFF BUTTON
Used to turn projection lamp on or off.
- 2** POWER INDICATORS
Lights dim when the projector is on.
Lights bright when the projector is stand-by position.
- 3** READY INDICATORS
Lights green when projector lamp is ready to be turned on.
- 4** TEMPERATURE WARNING INDICATOR
Flashes red when internal projector temperature is too high.
- 5** LAMP REPLACEMENT INDICATOR
Lights orange when projection lamp is nearing end of service life.
- 6** VOLUME BUTTONS
Used to adjust volume
- 7** MODE BUTTON
Used to select video source. (Computer Input or AV Input)
- 8** MENU BUTTON
 - Computer Mode
Used to select on-screen adjustment displays for brightness, contrast, horizontal position, vertical position, fine sync and memory. Press repeatedly to cycle.
 - AV Mode
Used to select on-screen adjustment displays for color, tint, contrast, brightness and sharpness. Press repeatedly to cycle.
- 9** LEVEL CONTROL BUTTONS
 - Computer Mode
Used to adjust brightness, contrast, horizontal position, vertical position, fine sync, memory, display, blue background, reverse R/L and reverse T/B by pressing + or - button.
 - AV Mode
Used to adjust color, tint, contrast, brightness, sharpness, display, blue background, reverse R/L and reverse T/B by pressing + or - button.
- 10** NORMAL BUTTON
Used to reset to normal picture adjustment preset by factory.
- 11** SYSTEM BUTTON
 - Computer Mode
Used to select computer system.
 - AV Mode
Used to select color system.
- 12** SETTING BUTTON
Used to select on-screen adjustment displays for focus setting pattern, display, blue background, reverse R/L and reverse T/B.
Press repeatedly to cycle.

FixYourProjector.com
 Discount Merchant.com (800) 281-8860
 THE TRUSTED SOURCE FOR PROJECTOR LAMPS AND ACCESSORIES

BACK OF THE PROJECTOR

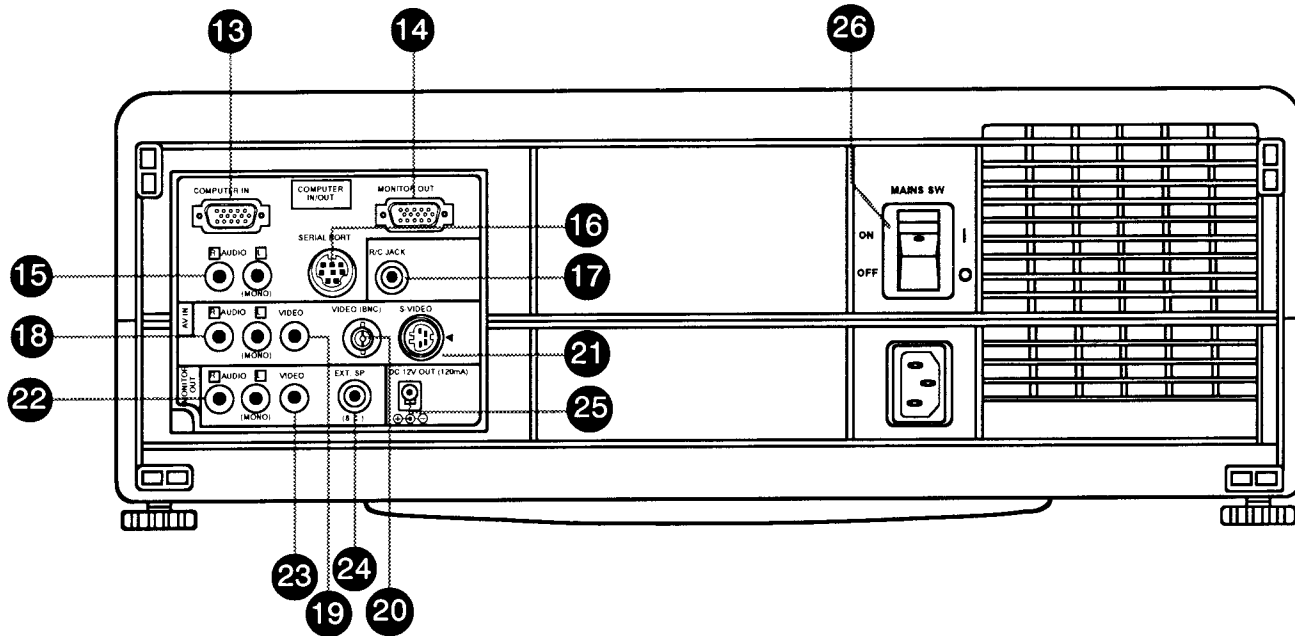

- 13** COMPUTER INPUT TERMINAL
Used to connect a computer to the projector.
- 14** MONITOR OUTPUT TERMINAL
Used to connect a monitor to the projector.
- 15** COMPUTER AUDIO INPUT JACKS
Used to connect a computer audio input to the projector.
- 16** SERIAL PORT CONNECTOR
Used to connect a computer to the projector.
- 17** WIRED REMOTE JACK
When using the wired remote control, connect the remote cable to this jack.
- 18** AUDIO INPUT JACKS
Used to connect an audio input to the projector.
- 19** VIDEO INPUT JACK
Used to connect a video source to the projector.
- 20** VIDEO INPUT (BNC) JACK
Used to connect a video source to the projector.
- 21** S-VIDEO INPUT JACK
Used to connect a S-VHS video source to the projector.
- 22** AUDIO MONITOR OUTPUT JACKS
Permits audio connection to a monitor.
- 23** VIDEO MONITOR OUTPUT JACK
Permits video connection to a monitor.
- 24** EXT. SP. JACK (3.5 mm mini type)
Used to connect a external monaural speaker system.
- 25** DC 12V SOURCE
Used to connect a DC source (12V, 120mA) for other equipment.
- 26** MAINS ON/OFF SWITCH
Used to turn the projector on.

FixYourDLP.com
Sponsored by DM

Discount-Merchant.com (800) 281-8860
THE TRUSTED SOURCE FOR PROJECTOR LAMPS AND ACCESSORIES

REMOTE CONTROL OPERATION

1 MODE BUTTON

Used to select video source. (Computer Input or AV Input)

2 POWER (LAMP) ON/OFF BUTTON

Used to turn projection lamp on or off.

3 SOUND MUTE BUTTON

Used to mute sound.

4 VOLUME BUTTONS

Used to adjust volume.

5 LEVEL CONTROL BUTTONS

● Computer Mode

Used to adjust brightness, contrast, horizontal position, vertical position, fine sync and memory by pressing + or - button.

● AV Mode

Used to adjust color, tint, contrast, brightness and sharpness by pressing + or - button.

6 NORMAL BUTTON

Used to reset to normal picture adjustment preset by factory.

7 MENU BUTTON

● Computer Mode

Used to select on-screen adjustment displays for brightness, contrast, horizontal position, vertical position, fine sync and memory. Press repeatedly to cycle.

● AV Mode

Used to select on-screen adjustment displays for color, tint, contrast, brightness and sharpness. Press repeatedly to cycle.

8 SYSTEM SELECT BUTTON

● Computer Mode

Used to select computer system.

● AV Mode

Used to select color system.

9 LIGHT UP BUTTON

Press to light the back light for function buttons on the remote control unit for 5 seconds. Press any other function button during the lighting to light for another 5 seconds.

10 WIRED REMOTE JACK

When using the wired remote control, connect the remote cable to this jack.

INFRARED/WIRED REMOTE CONTROL

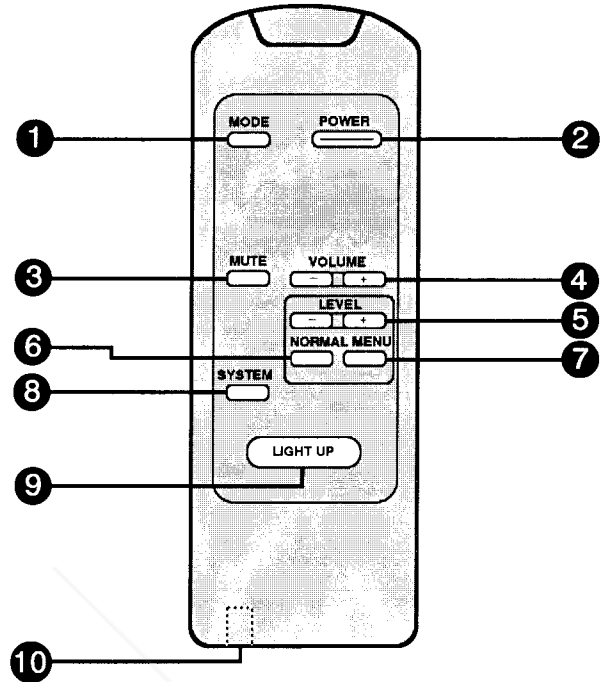

REMOTE CONTROL BATTERY INSTALLATION

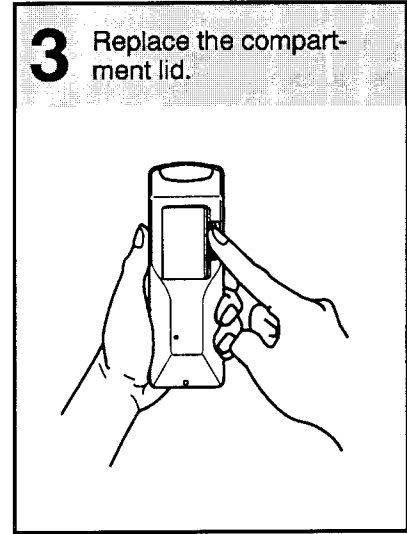
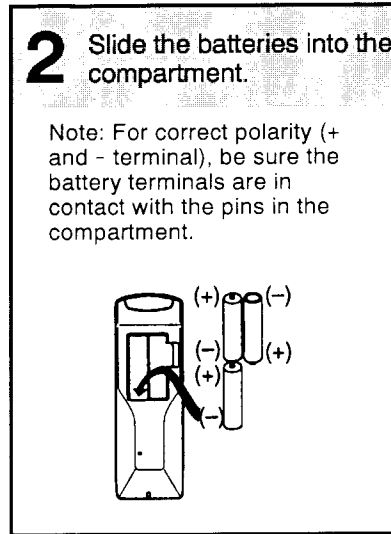
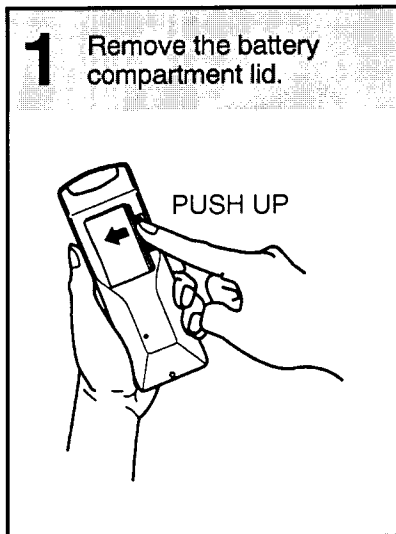

The remote control unit can be used as wireless or wired remote control.

USING THE REMOTE CONTROL UNIT (wireless)

Point the remote control toward the projector (Receiver window) whenever pressing the buttons. Maximum operating range for the remote control is about 16.4' (5m) and 60° (back of the projector) and 16.4' (5m) and 90° (front of the projector).

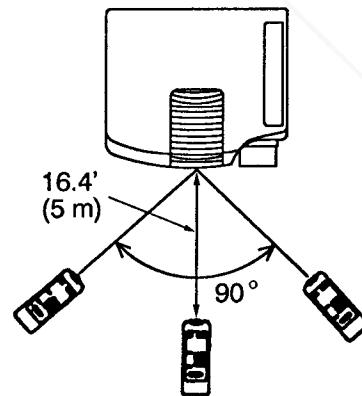
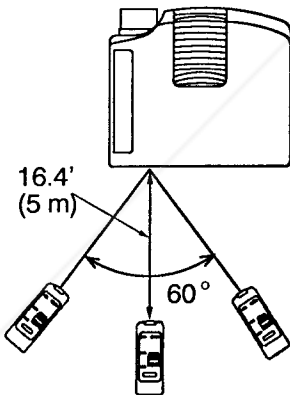

USING THE REMOTE CONTROL UNIT (wired)

Connect a remote control cable to RC jacks located on the remote control unit and the back of the projector.

To insure safe operation, please observe the following precautions:

- * Use (3) AA type batteries.
- * Change three batteries at the same time.
- * Do not use a new battery with a used battery.
- * Avoid contact with water.
- * Do not drop the remote control unit.

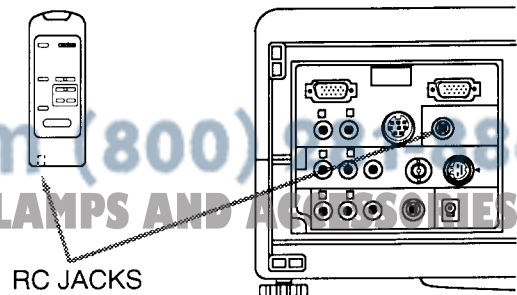

USING THE PROJECTOR

TO TURN ON THE PROJECTOR

Connect the projector to a video source (Computer, VCR, Video Camera, Video Disc Player, etc.) using the appropriate terminals on the rear of the projector (See page 6-9).

Connect the projector's AC power cord into a wall outlet and turn the MAINS ON/OFF switch (located on the back of the projector) to ON position. The POWER indicator will light RED and the READY indicator will light GREEN.

Press the POWER (LAMP) ON/OFF button on the projector or on the remote control unit to ON. The POWER indicator will light dim and the cooling fan will operate. The wait display (A MOMENT!/UN MOMENTO! and numeral 30) appears on the screen and the count-down starts (30-29-28...1). The signal from the video source appears after 30 seconds.

A MOMENT!/UN MOMENTO!



CAUTION:

- THIS PROJECTOR USES A METAL-HALIDE ARC LAMP. IF YOU TURN ON THE LAMP, DO NOT TURN IT OFF FOR AT LEAST 5 MINUTES SO THAT ITS LIFE WILL NOT GET SHORTER.
- DO NOT UNPLUG THE PROJECTOR OR TURN THE MAINS ON/OFF SWITCH (LOCATED ON THE BACK OF THE PROJECTOR) TO OFF UNTIL THE COOLING FAN HAS STOPPED OPERATING.

NOTE 1: After you turn off the projector using the POWER (LAMP) ON/OFF button on the projector (or on the remote control unit) you must wait one minute before you can turn the projector on again.

NOTE 2: TEMPERATURE WARNING INDICATOR flashes red, the projector will automatically turn off. Wait at least 5 minutes before turning the projector on.

If the TEMPERATURE WARNING INDICATOR continues to flash, follow the procedures below:

- (1). Press POWER (LAMP) ON/OFF button to OFF.
- (2). Check the air filter for dust accumulation.
- (3). Remove dust with vacuum cleaner (See air filter care and cleaning on page 20.)
- (4). Press POWER (LAMP) ON/OFF button to ON.

If the TEMPERATURE WARNING INDICATOR still continues to flash, call your authorized distributor or dealer for service.

TO TURN OFF THE PROJECTOR

Press the POWER (LAMP) ON/OFF button on the projector or on the remote control unit. The "⏻ POWER OFF ?" appears on the screen. Press again the POWER (LAMP) ON/OFF button to OFF the projector. The cooling fan will operate for 50 seconds after the projector is turned off and POWER indicator will light bright. (During this "cooling down" period, the projector can not be turned on.)

After 10 seconds, the READY indicator will light green again and the projector may be turned on by pressing the POWER (LAMP) ON/OFF button.

⏻ POWER OFF ?

ADJUST THE PROJECTOR

FOCUS ADJUSTMENT

Turn the focus ring using your fingers for sharper picture. When focusing, press setting button to select focus setting pattern. (See other function setting on page 17.)

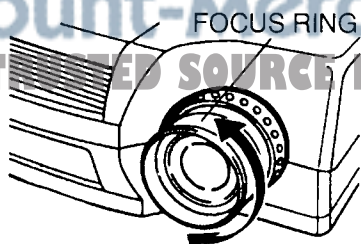

ZOOM ADJUSTMENT

Turn the zoom ring using zoom ring knob to obtain your desired picture size.

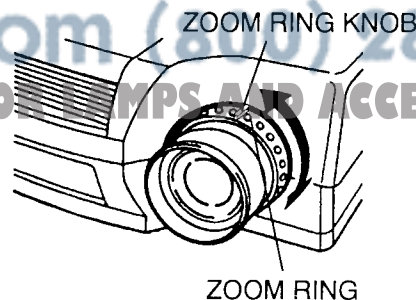

VIDEO MODE SELECT

Press the MODE button (located on projector or remote control unit) to select Computer Input or AV Input. The "COMPUTER" or "AV" display will appear on the screen.

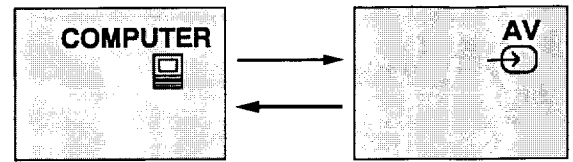

VOLUME ADJUSTMENT

Press VOLUME buttons (located on projector or remote control unit) to adjust the volume. The screen display will appear.

Pressing (+) will increase volume and the green indicator will increase to the right on the screen.

Pressing (-) will decrease volume and the green indicator will decrease to the left on the screen.

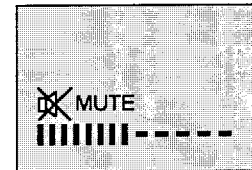
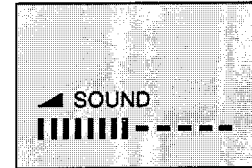

SOUND MUTE ADJUSTMENT

Pressing SOUND MUTE button on the remote control unit will mute audio. Press SOUND MUTE button again to restore audio to its previous level.

PICTURE ADJUSTMENT

The normal picture level is factory preset on the projector and can be obtained anytime by pressing the NORMAL button on the projector, or on the remote control unit. (The Normal display will appear for 5 seconds.)

Picture adjustments can be made by using the MENU and LEVEL buttons on the projector, or on the remote control unit. (See picture adjustment on page 18-19.)



SYSTEM SELECT

● COMPUTER MODE

When a computer is connected to the projector and both of the computer and the projector are turned On, the type of the connected computer system appears on the screen. (See "ON-SCREEN DISPLAY" on page 23.)

If any of the following 3 computer systems is connected to the projector and the projector cannot discriminate those systems, press the "SYSTEM" button to select the correct system of the connected computer.

1. "MAC II NORMAL" and "MAC LC 13RGB"
2. "VGA 640 X 400" and "VGA 720 X 400"
3. "VGA 640 X 480" and "GENOA"

For example; The display of "MAC II NORMAL" will appear on-screen when the signal comes from Mac II normal, Super Mac and/or Raster Ops.

In case of connecting Mac LC 13" RGB monitor, press SYSTEM button (located on projector or remote control unit) to select the display of "MAC LC 13RGB".

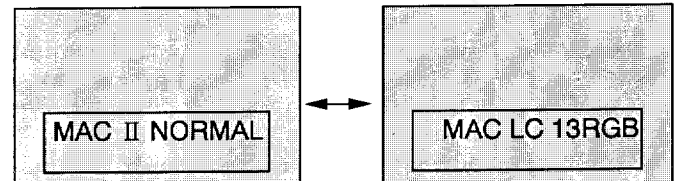

NOTE:

1. If no input signal from the computer, the "NO SIGNAL" display appears on the screen.

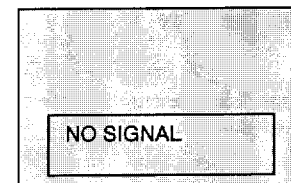

If the projector cannot discriminate the input signal from the computer, the "NOT COMPATIBLE" display appears on the screen.

● AV MODE

Press the SYSTEM button (located on projector or remote control unit) to select AUTO, PAL, SECAM, NTSC4.43 or NTSC.

Each time the SYSTEM button is pressed, the color system changes as follows:

When the color system is set to "AUTO" position, this projector can receive color programs from one of the 4 systems (PAL, SECAM, NTSC4.43 or NTSC), automatically.

If the picture quality is poor, make sure the proper color system is selected to match the video source.

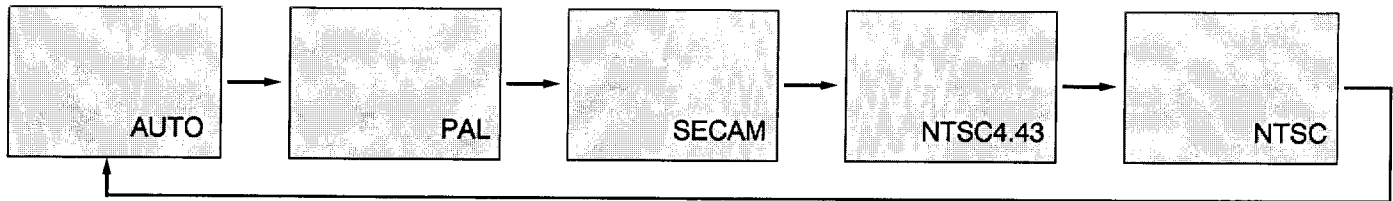

TEXT SELECT

(VGA 720 × 400 and VGA 640 × 400 used only)

Press the SYSTEM button (located on projector or remote control unit) to select "VGA 720 × 400"-TEXT- or "VGA 640 × 400"-GRAPHIC-.

NOTE: "720 × 400" TEXT mode is projected to be compressed as "640 × 400".

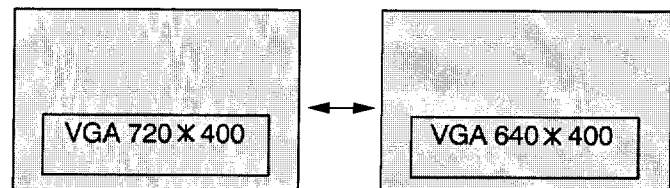

OTHER FUNCTION SETTING

This projector has other function settings; focus setting pattern, display, blue background, reverse R/L or reverse T/B. These setting by using SETTING and LEVEL buttons on the projector.

1. Press SETTING button to select the function.

Each time the SETTING button is pressed, the control function changes as follows:

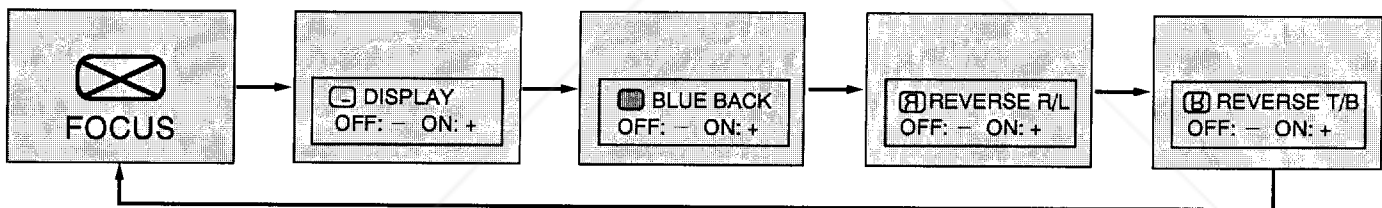

2. Adjust the display, blue background, reverse R/L and reverse T/B by pressing LEVEL (- and +) buttons.

3. The ON-SCREEN display will disappear automatically in 5 seconds.

FOCUS ADJUSTMENT PATTERN

This function lets you project an easier-to-focus picture on the screen. When focusing, select this function with the setting button. (The focus setting pattern will appear for 10 seconds.)

DISPLAY

When this function is "ON" position, the projector to see the on-screen display of all setting and adjustment will be appeared.

When this function is "OFF" position, the projector to see the on-screen display of any setting and adjustment (related of Picture Adjustment and Other function Setting) will be appeared.

BLUE BACK

When this function is in the "ON" position, the projector will project the blue image without video noise on the screen when the video source is unplugged or turned off.

REVERSE R/L

When this function is in the "ON" position, the left/right picture reverse capability lets you project onto a rear projection screen.

REVERSE T/B

When this function is in the "ON" position, the top/bottom picture reverse.

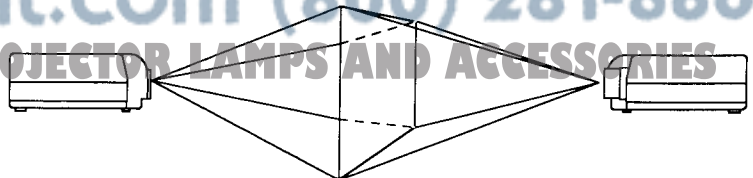

PICTURE ADJUSTMENTS

TOP CONTROLS OF THE PROJECTOR

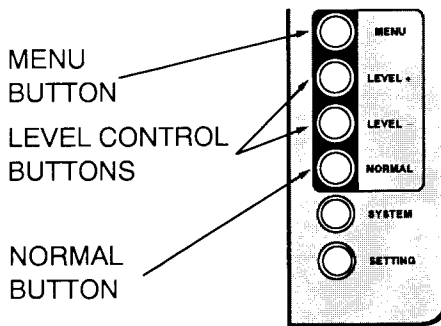

REMOTE CONTROL UNIT

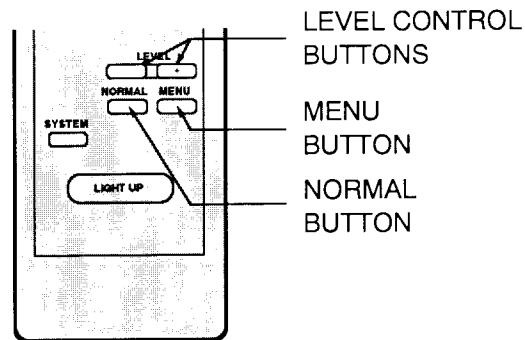

(A) COMPUTER MODE

Picture adjustments have been preset at the factory to our quality standards. The picture adjustments can be made by the MENU and LEVEL buttons on the projector or on the remote control unit.

1. Press the MENU button to select the picture adjustments function.
Each time the MENU button is pressed, the control function changes as follows:

NOTE: "V. POSITION" will be skipped, less than 480 line displays computer connected.

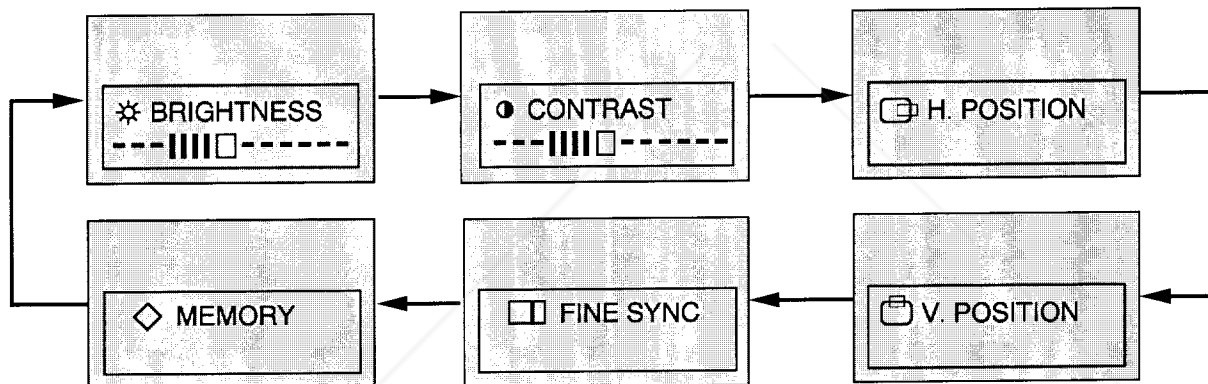

2. Adjust the brightness, contrast, H. position, V. position or fine sync by pressing the LEVEL (+ and -) buttons.
3. The ON-SCREEN display will disappear automatically in 5 seconds.

- + [] LEVEL [] ←-----■-----→	
BRIGHTNESS	DARKER ←→ BRIGHTER
CONTRAST	SOFTER ←→ SHARPER
H. POSITION	LEFT ←→ RIGHT
V. POSITION	DOWNWARD ←→ UPWARD
FINE SYNC	Press the LEVEL CONTROL buttons (- or +) as necessary to eliminate flicker from the display.

4. Then press the MENU button to select the MEMORY menu. Press the LEVEL + button to save the picture adjustment levels in memory.

NOTE: The projector is equipped with a built-in memory feature that can maintain the picture adjustment levels if the projector is turned off and AC power cord is disconnected. If the NORMAL button is pressed, the projector will return to factory preset level.

(B) AV MODE

Picture adjustments have been preset at the factory to our quality standards. The picture adjustments can be made by the MENU and LEVEL buttons on the projector or on the remote control unit.

1. Press the MENU button to select the picture adjustments function.
Each time the MENU button is pressed, the control function changes as follows:

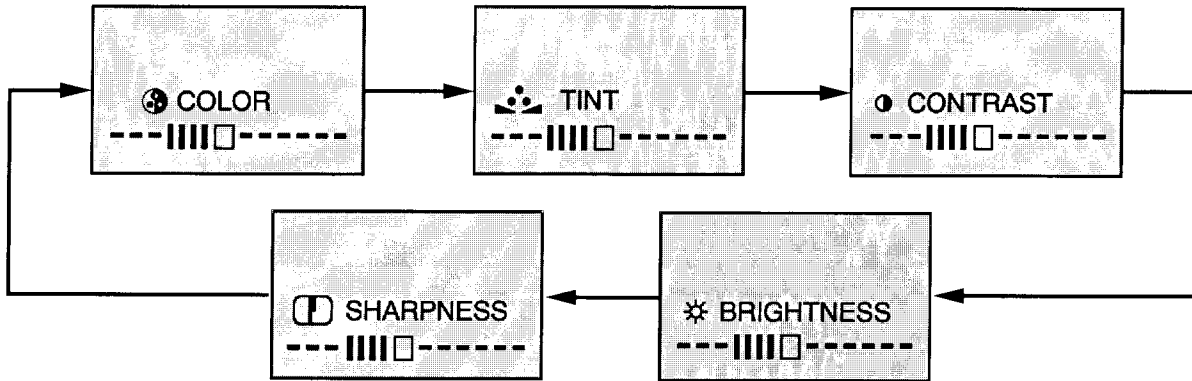

NOTE: TINT will be skipped during in the PAL and SECAM mode.

2. Adjust the color intensity, tint, contrast, brightness or sharpness by pressing the LEVEL (+ and -) buttons.
3. The ON-SCREEN display will disappear automatically in 5 seconds.

<ul style="list-style-type: none"> • Press the LEVEL CONTROL buttons to make adjustments. Refer to the control chart below. 	
COLOR	DECREASES ← → INCREASES
TINT	MORE PURPLE ← → MORE GREEN
CONTRAST	SOFTER ← → SHARPER
BRIGHTNESS	DARKER ← → BRIGHTER
SHARPNESS	SOFTER ← → SHARPER

NOTE: The projector is equipped with a built-in memory feature that can maintain the picture adjustment levels if the projector is turned off and AC power cord is disconnected. If the NORMAL button is pressed, the projector will return to factory preset level.



Discount-Merchant.com (800) 281-8860
THE TRUSTED SOURCE FOR PROJECTOR LAMPS AND ACCESSORIES

AIR FILTER CARE AND CLEANING

The removable air filter prevents dust from accumulating on the surface of the projection lens and projection mirror. Should the air filter become clogged with dust particles, it will reduce the cooling fan's effectiveness and may result in internal heat built up and reduce the life of the projection lamp.

The air filter should be cleaned about every 100 hours. Clean the air filter more often when the projector is used in a particularly dusty or smoky place.

When the air filter is blackened and beyond cleaning, it is time to change new air filter. Request service from an authorized dealer or service station.

Be sure to face the air filter in the correct direction when installing inside of the filter cover. Attach the air filter with the arrow on the "AIR FLOW" label facing towards the inside of the projector.

To clean the air filter, follow the cleaning procedures below:

1. Turn the POWER (LAMP) ON/OFF button OFF.
2. Remove the air filter cover from the side of the projector.
3. Remove the air filter and sponge from the filter cover.
4. Clean the air filter and sponge with a vacuum cleaner.
5. Replace the air filter and sponge. Make sure that air filter cover is fully inserted.

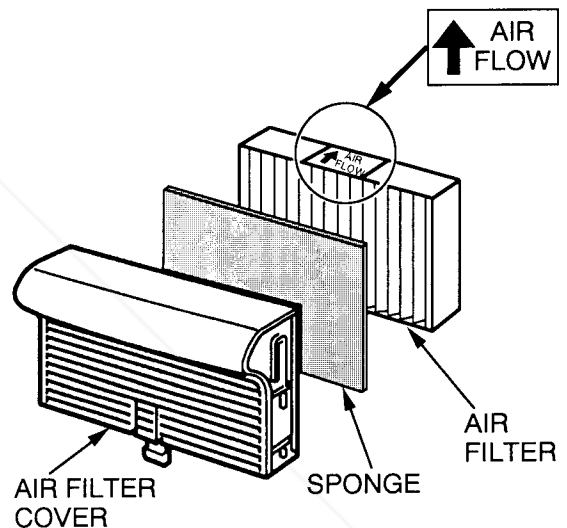
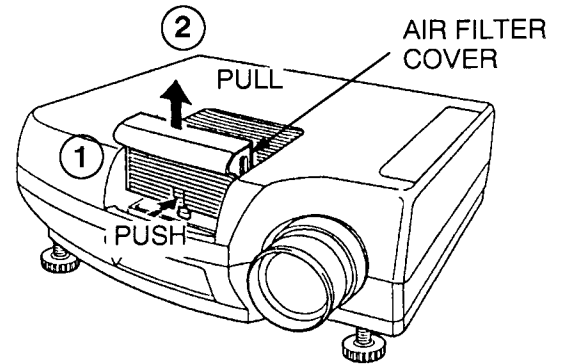

Do not clean with water. Doing so may damage the air filter.
Do not operate the projector with air filter removed.

RECOMMENDATION

TO ENJOY PICTURE IMAGE, USE THE PROJECTOR IN THE CLEAN ENVIRONMENT. USAGE IN THE CLEAN ENVIRONMENT IS RECOMMENDED.

When used under the dusty or smoky conditions, dust may accumulate on the liquid crystal panel and lens inside it, and may resultantly be projected on the screen together with the picture.

When the above symptoms are noticed contact the place where your purchased or the nearest service center for the cleaning.

LAMP REPLACEMENT & TEMPERATURE WARNING INDICATORS

LAMP REPLACEMENT INDICATOR

When the lamp nears the end of its service life, the picture quality and color quality will deteriorate and the lamp replacement indicator will light orange.



DO NOT ATTEMPT TO REMOVE OR CHANGE THE PROJECTION LAMP. THE LAMP CAN ONLY BE CHANGED BY QUALIFIED SERVICE PERSONNEL.

TEMPERATURE WARNING INDICATOR

The TEMPERATURE WARNING INDICATOR flashes red when the internal temperature of the projector exceeds the normal temperature.

Possible causes for the temperature warning may be:

1. Ventilation slots at the front or rear of the projector are blocked. In such an event, reposition the projector so that ventilation slots are not obstructed.
2. Air filter is clogged with dust particles. Remove dust from the air filter by following instructions in the Air Filter Care and Cleaning section above.

If temperature warning indicator remains on after performing the checks listed above, cooling fan/internal circuits may be malfunctioning. Request service from an authorized dealer or service station.

HELPFUL HINTS-Problems and Solutions

Check the following chart before requesting service.

Problem:	Try these Solutions:
No power	<ul style="list-style-type: none"> ● Plug the projector into an AC outlet. ● Turn the MAINS ON/OFF button to ON. ● Press the POWER (LAMP) ON/OFF switch to ON. ● Check the READY INDICATOR light ON. ● One minute has not passed after the projector turned OFF. <p>NOTE: After pressing the POWER (LAMP) ON/OFF button to OFF , the projector functions as follows.</p> <ol style="list-style-type: none"> 1. The READY indicator will turn off. 2. The cooling fan will operate for 50 seconds after the projector is turned off and POWER indicator will light bright. (During this "cooling down period, the projector can not be turned on.) 3. After 10 seconds, the READY indicator will light green again and the projector may be turned on by pressing the POWER (LAMP) ON/OFF button.
No sound from built-in speaker	<ul style="list-style-type: none"> ● Press the VOLUME (▲) and (▼) to (▲). ● Check audio cable connection from audio input source.
No color	<ul style="list-style-type: none"> ● Check color system.
Picture is reversed	<ul style="list-style-type: none"> ● Check REVERSE SCAN (R/L or T/B) Feature.
Picture blurred or color faded	<ul style="list-style-type: none"> ● Check the projection distance 4.9' (1.5 m) ~ 39.4' (12.0 m). ● Adjust the FOCUS control. <p>NOTE: Moving the projector from a cool temperature location to a warm temperature location may result in moisture condensation on the lens. In such an event, leave the projector OFF and wait until condensation disappears.</p>

SERVICE

WARNING: High voltages are used to operate this projector. Do not remove the back from

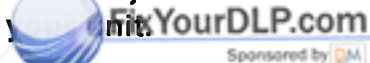

You can often correct operating problems yourself. If the projector fails to work properly, locate the operating problem in the Helpful Hints Chart. To correct them, try the "Solutions."

Sanyo Service is easily obtained. If after following all operating instructions, you find that service is necessary, contact the SFS Corporation in Los Angeles, or the store where you purchased the unit. Give the model number and explain the difficulty. We will advise you how to obtain service.

TECHNICAL SPECIFICATIONS

SPECIFICATIONS

Projector Type	Portable LCD Data-Grade Color Projector
Dimensions (H x W x D)	6.2" (158 mm) × 16.9" (430 mm) × 15.2" (385 mm)
Net Weight	21.8 lbs (9.9 kg)
LCD Panel System	1.3" TFT Active Matrix type (Thin Film Transistor) × 3
Number of Pixels	921,600 (307,200 × 3)
Color System	4 color system (PAL, SECAM, NTSC4.43 and NTSC)
Projection Image Size (Diagonal)	Adjustable from 30" to 300"
Contrast Ratio	100 :1
Horizontal Resolution	550 TV lines
Projection Lens	f2.8 ~ 3.2 lens with 2.09"~2.72" Manual zoom and focus
Lens Aperture	2.04" (51.8 mm)
Throw Distance	4.9' (1.5 m) ~ 39.4' (12.0 m)
Projection Lamp	Metal Halide, 200 watt type
Projection Mirror	Dichroic mirror system
AV Input jacks	RCA Type × 1 (Video, Audio R and L), BNC Type × 1 and DIN 4 pin (S-Video) × 1
Computer Input Jack	HDB15 Terminal × 1, DIN 8 pin (Serial port)
Monitor Output Jack	HDB15 Terminal × 1
Computer Audio Input Jack	RCA Type × 1 (R and L)
Video Monitor Output Jack	RCA Type × 1
Audio Monitor Output Jacks	RCA Type × 1 (R and L)
Other Jacks	EXT. Speaker Jack × 1, Wired Remote Jack × 1 and External Power Supply (+12V DC, 120mA)
Built-in Speaker	INT. SP. Monaural, 3 watt RMS (T.H.D. 10%)
Image Elevation Adjustment	Up 6°
Voltage	120V AC, 50/60 Hz
Power Consumption	285 Watts/4.6A (Max. Ampere)
Operating Temperature	5°C ~ 35°C
Storage Temperature	- 10°C ~ 60°C
Remote Control Battery	(3) AA Type
Standard Accessories	Remote Control Unit, R/C Cable 5' (1.5m), Software Kit, AC Power Supply Cord, VGA Cable, MAC Cable, Lens Cover , Owner's Instruction Manual and Protective Dust Cover



Discount-Merchant.com (800) 281-8860



This symbol on the nameplate means the product is Listed by Underwriters Laboratories Inc. It is designed and manufactured to meet rigid U.L. safety standards against risk of fire, casualty and electrical hazards.

COMPATIBLE PERSONAL COMPUTER SPECIFICATIONS

ON-SCREEN DISPLAY	COMPATIBLE COMPUTER	DOT × LINES	fH (kHz)	1V (LINE)	POLA.	
					H	V
FMT 640 × 400	FM-TOWNS (640 × 400)	640 × 400	24.37	440	--	--
PC98 640 × 400	PC-9801 (640 × 400)	640 × 400	24.83	440	--	--
	PC-9821 (640 × 400)	640 × 400	24.83	440	--	--
AT&T	AT&T6300 (350 LINE)	640 × 350	25.86	432	+	+
	AT&T6300 (400 LINE)	640 × 400	25.86	432	+	+
AX286/386	AX-286/386	640 × 480	30.27	501	+	--
VGA 640 × 400	VGA 640 × 400	640 × 400	31.47	449	--	+
VGA 720 × 400	VGA 720 × 400	720 × 400	31.47	449	--	+
VGA 640 × 350	VGA 640 × 350	640 × 350	31.47	449	+	--
VGA 640 × 480	VGA 640 × 480	640 × 480	31.47	525	--	--
	PC-9821 (640 × 480)	640 × 480	31.47	525	--	--
	FM-TOWNS (640 × 480)	640 × 480	31.47	525	--	--
	MBC-P100J	640 × 480	31.47	525	--	--
	J-3100VS	640 × 480	31.47	525	--	--
	T-4500C	640 × 480	31.32	525	--	--
GENOA	GENOA 6000 (60 Hz)	640 × 480	31.47	525	--	--
VGA 640 × 400 525 LINE	VGA 640 × 400 525 LINE	640 × 400	31.47	525	--	+
VGA 640 × 350 525 LINE	VGA 640 × 350 525 LINE	640 × 350	31.47	525	+	--
MAC II NORMAL	MAC II (NORMAL)	640 × 480	35.00	525	--	+
	MAC II (SuperMac)	640 × 480	35.00	525	--	+
	MAC II (RasterOps)	640 × 480	35.00	525	--	+
MAC LC 13RGB	MAC LC (13"RGB-MO)	640 × 480	34.97	525	--	--
VESA	VESA VS901001	640 × 480	37.86	520	--	--
GENOA	GENOA 6000 (70 Hz)	640 × 480	37.90	509	--	+

Specifications are subject to change without notice.



Discount-Merchant.com (800) 281-8860
THE TRUSTED SOURCE FOR PROJECTOR LAMPS AND ACCESSORIES

SANYO INDUSTRIAL VIDEO LCD PROJECTOR LIMITED WARRANTY

OBLIGATIONS

In order to obtain warranty service, the product must be delivered to and picked up from an Authorized Sanyo Service Center at the user's expense, unless specifically stated otherwise in this warranty. The names and addresses of Authorized Sanyo Service Centers may be obtained by writing to SFS Corporation, SFC's warranty administrator, at any of the addresses listed below, or by calling (toll-free) 1-800-421-5013.

New Jersey Office
210 Riser Road
Little Ferry, NJ 07643
201-641-3000

California Office
1200 W. Artesia Blvd.
Compton, CA 90220
310-537-5830

Illinois Office
900 N. Arlington Heights Road
Itasca, IL 60143 U.S.A.
708-775-1414

THIS WARRANTY IS VALID ONLY ON SANYO PRODUCTS PURCHASED OR RENTED IN THE UNITED STATES OF AMERICA, EXCLUDING HAWAII AND ALL U.S. TERRITORIES AND PROTECTORATES. THIS WARRANTY APPLIES ONLY TO THE ORIGINAL RETAIL USER. THE ORIGINAL DATED BILL OF SALE, SALES SLIP OR RENTAL AGREEMENT MUST BE SUBMITTED TO THE AUTHORIZED SANYO SERVICE CENTER AT THE TIME WARRANTY SERVICE IS REQUESTED.

Subject to the OBLIGATIONS above and EXCLUSIONS below, SANYO FISHER (USA) CORPORATION (SFC) warrants this SANYO product against defects in materials and workmanship for the periods specified below. SFC will repair or replace (at its option) the product and any of its parts which fail to conform to this warranty. The warranty period commences on the date the product was first purchased or rented at retail.

LABOR	PARTS	LAMP
1 YEAR	1 YEAR	90 DAYS

EXCLUSIONS

This warranty does not cover (A) the adjustment of customer-operated controls as explained in the appropriate model's instruction manual, or (B) the repair of any product whose serial number has been altered, defaced or removed.

This warranty shall not apply to the cabinet or cosmetic parts, knobs or batteries.

This warranty does not apply to uncrating, setup, installation, removal of the product for repair or reinstallation of the product after repair.

This warranty does not apply to repairs or replacements necessitated by any cause beyond the control of SFC including, but not limited to, any malfunction, defect or failure caused by or resulting from unauthorized service or parts, improper maintenance, operation contrary to furnished instructions, shipping or transit accidents, modification or repair by the user, abuse, misuse, neglect, accident, incorrect power line voltage, fire, flood or other Acts of God, or normal wear and tear.

The foregoing is in lieu of all other expressed warranties and SFC does not assume or authorize any party to assume for it any other obligation or liability.

THE DURATION OF ANY WARRANTIES WHICH MAY BE IMPLIED BY LAW (INCLUDING THE WARRANTIES OF MERCHANTABILITY AND FITNESS) IS LIMITED TO THE TERM OF THIS WARRANTY. IN NO EVENT SHALL SFC BE LIABLE FOR SPECIAL, INCIDENTAL OR CONSEQUENTIAL DAMAGES ARISING FROM OWNERSHIP OR USE OF THIS PRODUCT, OR FOR ANY DELAY IN THE PERFORMANCE OF ITS OBLIGATIONS UNDER THIS WARRANTY DUE TO CAUSES BEYOND ITS CONTROL.

SOME STATES DO NOT ALLOW LIMITATIONS ON HOW LONG AN IMPLIED WARRANTY LASTS AND/OR DO NOT ALLOW THE EXCLUSION OR LIMITATION OF CONSEQUENTIAL DAMAGES, SO THE ABOVE LIMITATIONS AND EXCLUSIONS MAY NOT APPLY TO YOU.

THIS WARRANTY GIVES YOU SPECIFIC LEGAL RIGHTS. YOU MAY HAVE OTHER RIGHTS, WHICH VARY FROM STATE TO STATE.

ATTENTION

For your protection in the event of theft or loss of this product, please fill in the information below for your own personal records.

Model No. _____

Serial No. _____

(Located on back or bottom side of unit.)

Date of Purchase _____ Purchase Price _____

Where Purchased _____

21350 Lassen Street
Chatsworth, California 91311

Printed in Japan

Part No. 610 262 5752 (1AA6P1P0965-- M6GA)

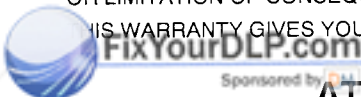



Disclaimer

This user manual is provided as a free service by FixYourDLP.com. FixYourDLP is in no way responsible for the content of this manual, nor do we guarantee its accuracy. FixYourDLP does not make any claim of copyright and all copyrights remain the property of their respective owners.

About FixYourDLP.com

FixYourDLP.com (<http://www.fixyourdpl.com>) is the World's #1 resource for media product news, reviews, do-it-yourself guides, and manuals.

Informational Blog: <http://www.fixyourdpl.com>

Video Guides: <http://www.fixyourdpl.com/guides>

User Forums: <http://www.fixyourdpl.com/forum>

FixYourDLP's Fight Against Counterfeit Lamps:

<http://www.fixyourdpl.com/counterfeits>

Sponsors:

RecycleYourLamp.org – Free lamp recycling services for used lamps:

<http://www.recycleyourlamp.org>

Lamp Research - The trusted 3rd party lamp research company:

<http://www.lampresearch.com>

Discount-Merchant.com – The worlds largest lamp distributor:

<http://www.discount-merchant.com>



FixYourDLP.com

Sponsored by 