



Disclaimer

This user manual is provided as a free service by FixYourDLP.com. FixYourDLP is in no way responsible for the content of this manual, nor do we guarantee its accuracy. FixYourDLP does not make any claim of copyright and all copyrights remain the property of their respective owners.

About FixYourDLP.com

FixYourDLP.com (<http://www.fixyourdlp.com>) is the World's #1 resource for media product news, reviews, do-it-yourself guides, and manuals.

Informational Blog: <http://www.fixyourdlp.com>

Video Guides: <http://www.fixyourdlp.com/guides>

User Forums: <http://www.fixyourdlp.com/forum>

FixYourDLP's Fight Against Counterfeit Lamps:

<http://www.fixyourdlp.com/counterfeits>

Sponsors:

RecycleYourLamp.org – Free lamp recycling services for used lamps:

<http://www.recycleyourlamp.org>

Lamp Research - The trusted 3rd party lamp research company:

<http://www.lampresearch.com>

Discount-Merchant.com – The worlds largest lamp distributor:

<http://www.discount-merchant.com>



FixYourDLP.com

Sponsored by 

hp
xp8010 series
digital projector



reference guide



Discount-Merchant.com (800) 281-8860
THE TRUSTED SOURCE FOR PROJECTOR LAMPS AND ACCESSORIES

Notice

The information contained herein is subject to change without notice. The only warranties for HP products and services are set forth in the express warranty statements accompanying such products and services. Nothing herein should be construed as constituting an additional warranty. HP shall not be liable for technical or editorial errors or omissions contained herein.

Consumer transactions in Australia and the United Kingdom: The above disclaimers and limitations shall not apply to Consumer transactions in Australia and the United Kingdom and shall not affect the statutory rights of Consumers.

© Copyright 2003, 2004 Hewlett-Packard Development Company, L.P. Reproduction, adaptation, or translation of this manual is prohibited without prior written permission of Hewlett-Packard Company, except as allowed under the copyright laws.

The programs that control this product are copyrighted and all rights are reserved. Reproduction, adaptation, or translation of those programs without prior written permission of Hewlett-Packard Co. is also prohibited.

Microsoft® and Windows® are U.S. registered trademarks of Microsoft Corporation. Adobe® and Acrobat® are trademarks of Adobe Systems Incorporated.

Hewlett-Packard Company
Digital Projection and Imaging
1000 NE Circle Blvd.
Corvallis, OR 97330

Second Edition (April 2004)



Discount-Merchant.com (800) 281-8860
THE TRUSTED SOURCE FOR PROJECTOR LAMPS AND ACCESSORIES

Contents

1 Installation and Setup

What's in the Box?	8
Identifying Common Features	9
Projector at a glance	10
Projector buttons and lights	11
Back panel	12
Remote control	14
Accessories	16
Selecting a Location	17
To install on a table	18
To install on the ceiling	18
To install for rear projection	21
To install the cable shroud	22
Turning On and Off	23
To connect power	23
To turn the projector on	24
To turn the projector off	25
To operate the remote control	25
To reset the projector	26
Making Initial Connections	27
To connect input sources	27
To connect output devices	32
To connect control equipment	33
Configuring the Projector	34
To change settings using the on-screen menu	34
To set up network access	35
Securing the Projector	36

2 Adjustments

Making Basic Adjustments	37
To aim the projector	38
To adjust the focus and zoom	39
To adjust the audio	39
Adjusting the Picture	40
To adjust the image according to type of picture	40
To adjust other image settings	40
To make adjustments from the web	41

3 Presentations

Connecting and Preparing	43
To connect a computer using a VGA cable	44
To connect a handheld organizer	45
To connect a computer using other types of cables	46
To connect other video sources	48
Showing Presentations	49
To present from a computer	49
To change the source	50
To hide or show the display	50
Disconnecting	51

4 System Management

Managing the Projector	53
To find the IP address	53
To set basic projector properties	54
To set up email for notifications	55
To protect configuration changes	55
Upgrading the Projector	56
To update the firmware	56
To install an add-on lens	57
To change the connectivity module	59



5 Maintenance

Using the On-Screen Menu	61
Quick Choice menu	62
Input menu	62
Adjust Picture menu	64
Audio menu	66
Setup menu	66
Help menu	67
Performing Routine Maintenance	68
To get the projector status	68
To clean the projector lens	68
To replace the lamp module	69
To replace the battery in the remote control	70

6 Troubleshooting

Troubleshooting Suggestions	71
Start-up problems	72
Picture problems	73
Sound problems	77
Interruption problems	78
Remote control problems	79
Networking problems	79
Testing the Projector	81
To run the projector diagnostics	81

7 Reference

Specifications	83
Safety Information	90
Safety precautions	90
Laser safety	90
LED safety	91
Mercury safety	91

Contents

Regulatory Information	92
U.S.A.	92
Canada.....	92
Japan	93
Korea.....	93
International.....	94

Index



Discount-Merchant.com (800) 281-8860 *Reference Guide*

THE TRUSTED SOURCE FOR PROJECTOR LAMPS AND ACCESSORIES

Installation and Setup

The chapter explains how to install and set up the HP digital projector.

If you are a presenter who is setting up the projector for short-term use, see Chapter 3, “Presentations.”

This chapter covers:

- “Identifying Common Features” on page 9.
- “Selecting a Location” on page 17.
- “Turning On and Off” on page 23.
- “Making Initial Connections” on page 27.
- “Configuring the Projector” on page 34.
- “Securing the Projector” on page 36.

What's in the Box?

Before setting up your projector, be sure your shipping box includes the following items. If the shipping box does not contain any of the following items, contact HP.

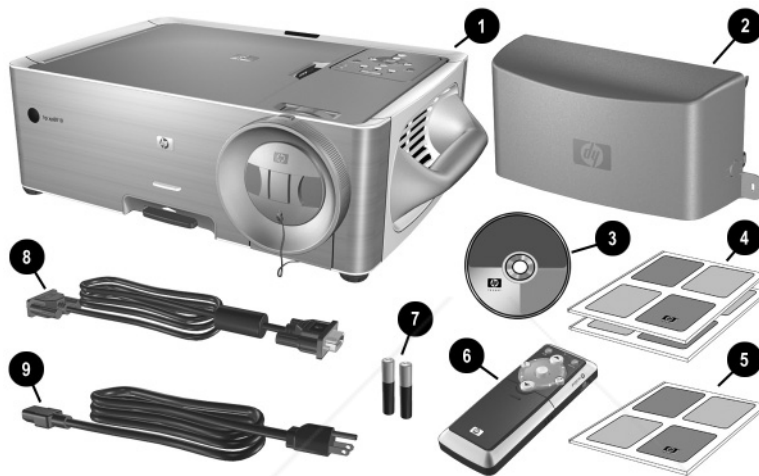

Identifying the contents of the box

Symbol	Item	Function
①	Projector	Displays images.
②	Cable shroud	Covers cable connections.
③	Documentation CD	Contains projector documentation.
④	Warranty and support guides	Provide warranty and support information.
⑤	<i>Quick Setup Guide</i>	Provides setup instructions.
⑥	Remote control	Controls projector.
⑦	Two AAA batteries	Powers remote control.
⑧	VGA to VGA cable	Connects projector to computer.
⑨	Power cord	Connects projector to power source.

Identifying Common Features

This section identifies common features and functions of the projector. The section covers:

- “Projector at a glance” on page 10.
- “Projector buttons and lights” on page 11.
- “Back panel” on page 12.
- “Remote control” on page 14.
- “Accessories” on page 16.

Projector at a glance



Identifying the projector

Symbol	Item	Function
①	Infrared receiver	Receive signals from the remote control.
②	Cover latch	Releases cover for replacing lamp module and connectivity module.
③	Control panel	Contains buttons and lights.
④	Zoom ring	Enlarges picture size 100–120%.
⑤	Focus ring	Focuses at distances of 1.5–14 m (5–46 ft).
⑥	Lens cover	Protects lens.
⑦	Height adjustment	Adjusts the height of the picture.

Projector buttons and lights

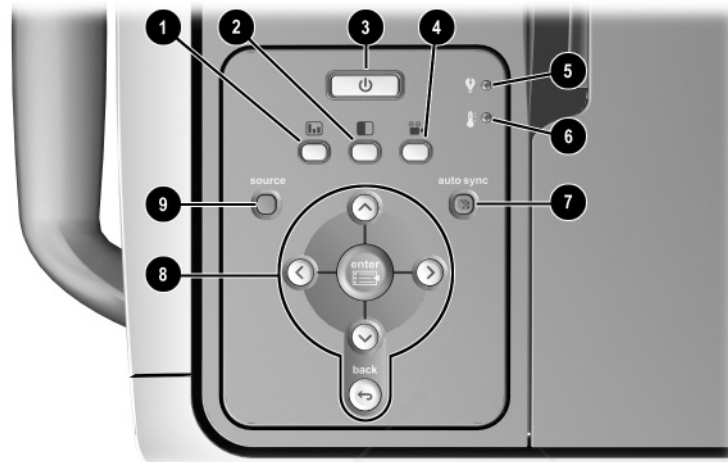

Identifying buttons and lights on the projector

Symbol	Item	Function
①	Business graphics button	Optimizes the picture for data input.
②	Super bright button	Maximizes brightness (grayscale picture).
③	Power button	Turns the projector on or off. Blinks during warm-up and cool-down.
④	Theatre video button	Optimizes the picture for video input.
⑤	Lamp-warning light	Turns on when lamp fails.
⑥	Temperature-warning light	Turns on when the internal temperature is too high.
⑦	Auto sync button	Resynchronizes the projector to input signal.
⑧	Enter button, back button, and directional arrows	Change projector settings using the on-screen menu.
⑨	Source button	Switches to the next input source.

Back panel

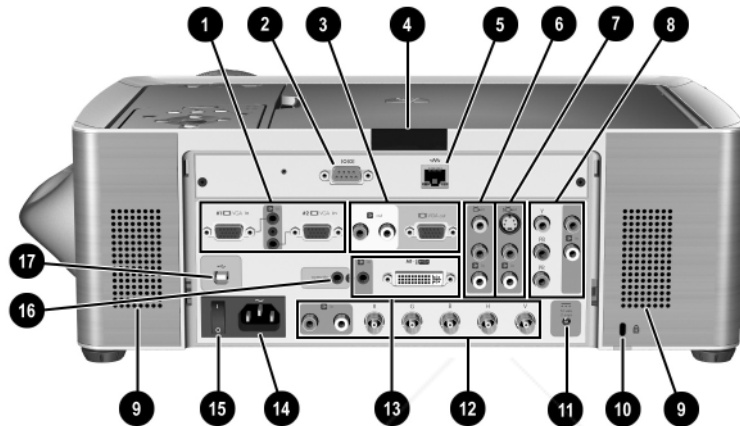

Identifying the back panel

Symbol	Item	Function
①	VGA #1 and VGA #2 input connectors	Connects desktop or notebook computers or pocket PCs.
②	RS232 port	Connects control equipment. Also used for firmware upgrades.
③	VGA-out and audio-out	Connects to a monitor or second projector. Connects to amplified speakers or audio equipment.
④	IR receiver	Receives infrared signals from the remote control.
⑤	LAN port	Connects the projector to a network.
⑥	Composite-video input	Connects devices like VCRs.
⑦	S-video input	Connects devices like VCRs or camcorders.
⑧	Component-video input	Connects advanced DVD players or HDTV devices with YPbPr output.

Identifying the back panel *(continued)*

Symbol	Item	Function
⑨	Speakers	Provides stereo sound.
⑩	Security slot	Secures the projector using a cable lock.
⑪	Control power output	Controls a motorized screen or similar device.
⑫	Analog video input	Connects various equipment with RGB, RGBS, RGBHV, and YPbPr output.
⑬	M1 input	Connects various equipment with analog- and digital-video output. Also supports USB-device output.
⑭	Main power	Connects power cord to projector.
⑮	Main disconnect switch	Disconnects power. Turn off only when disconnecting power cord.
⑯	Remote input	Provides a wired connection for the remote control, such as for rear projection.
⑰	USB device output	Sends mouse and keyboard signals from the remote control to a computer.



Certain models contain an L1581A Advanced Connectivity Module with additional ports. See the L1581A manual for information about using this module.

Remote control



Before using the remote control, install two AAA batteries.

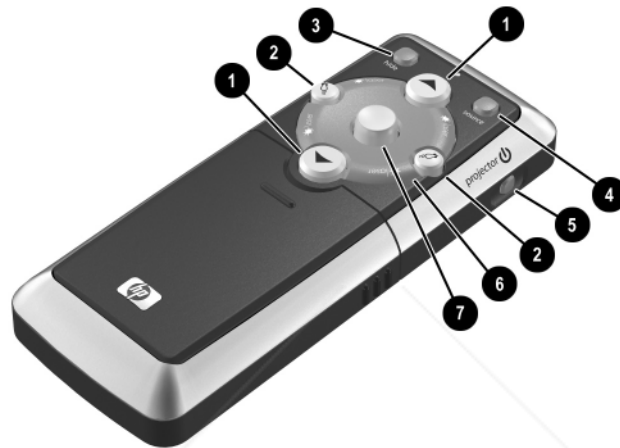

Identifying the remote control with case closed

Symbol	Item	Function
❶	Page up and page down	Scrolls up and down through pages on a connected computer.
❷	Left-click and right-click mouse functions	Performs left-click and right-click functions for a connected computer.
❸	Hide	Hides the display.
❹	Source	Switches to the next input source.
❺	Power	Powers on and off the projector.
❻	Laser ring	Turns on the laser pointer.
❼	Mouse button	Moves the mouse pointer on a connected computer.



WARNING: To reduce the risk of injury to the eyes, do *not* look directly into the remote control laser light, and do *not* point the laser light into anyone's eyes.

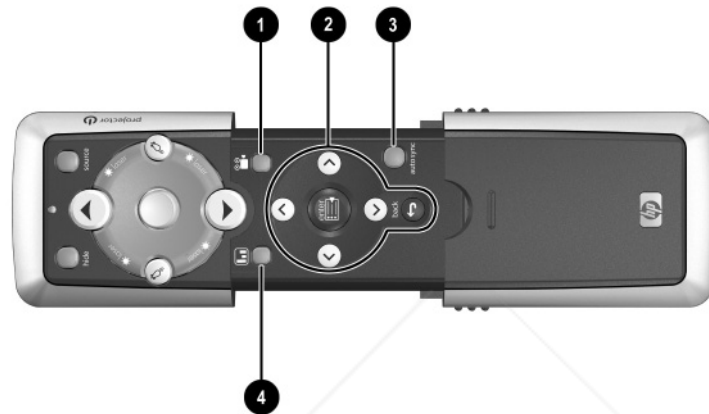

Identifying remote control with case open

Symbol	Item	Function
①	Theatre video button	Optimizes the picture for video input.
②	Menu buttons	Change projector settings using the on-screen menu.
③	Auto sync	Resynchronizes the projector to the input signal.
④	Business graphics button	Optimizes the picture for data input.

Accessories

The following list displays some of the accessories you can buy for the HP projector:

- Advanced connectivity module (add an optional 802.11b card for wireless computer connections and more)
- Add-on lens
 - Short-throw
 - Long-throw
- Carrying case
- Ceiling mount
- Projector screen
- Power cables
- Replacement lamp module
- Video cables

Selecting a Location

This section describes how to set up and plan for installing the projector:

- “To install on a table” on page 18
- “To install on the ceiling” on page 18
- “To install the cable shroud” on page 22
- “To install for rear projection” on page 21

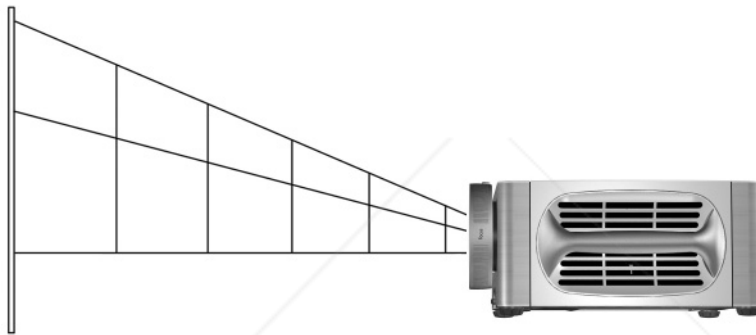

Setting up the projector with respect to image size

Distance from screen		Diagonal size of projected image		Width of projected image	
1.5 m	5 ft	0.8–0.9 m	31–37 in.	0.6–0.8 m	25–30 in.
2 m	7 ft	1.1–1.3 m	41–50 in.	0.8–1.0 m	33–40 in.
4 m	13 ft	2.1–2.5 m	83–99 in.	1.7–2.0 m	66–80 in.
6 m	20 ft	3.2–3.8 m	124–149 in.	2.5–3.0 m	99–119 in.
8 m	26 ft	4.2–5.1 m	165–199 in.	3.4–4.0 m	132–159 in.
10 m	33 ft	5.3–6.3 m	207–249 in.	4.2–5.1 m	165–199 in.
12 m	39 ft	6.3–7.6 m	248–298 in.	5.0–6.1 m	199–239 in.
14 m	46 ft	7.4–8.8 m	289–348 in.	5.9–7.1 m	232–278 in.

If you do not want to use the distance table, you can use the following equations to help determine where to install the projector relative to the screen.

Calculating projection dimensions

distance from screen = $A \times$ width of screen
min and max distance from screen = B
width of screen = $0.8 \times$ diagonal of screen (for 4:3 screen)
projector lens at same level as bottom or top of screen

$$A = 1.98 \text{ to } 2.38$$
$$B = 1.5 \text{ to } 14 \text{ m (5 to 46 ft)}$$

If your installation does not fall within these ranges, an add-on lens might be required. See “To install an add-on lens” on page 57.

To install on a table

1. Place the projector on a stable platform located 1.5 to 14 m (5 to 46 ft) in front of the screen.
2. Connect all necessary cables to the projector.
3. If necessary, set the projector to match the installation. Open the on-screen menu and select **setup > Projector position**. Then choose **Front Table** from the drop-down list.

To install on the ceiling

Your ceiling mount might differ from the one shown in the following images. However, the installation steps are basically the same.



HP recommends that a qualified carpenter or electrician install the ceiling mount.

1. Align the end of the ceiling-mount bracket **1** with the center hole in the lower-mount bracket **2**, and firmly secure it with a washer **3** and bolt **4**.

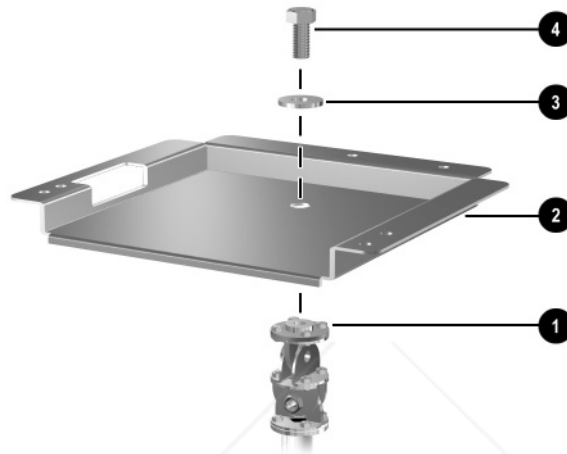

2. Align the three holes on the projector with the lower-mount bracket and firmly secure with three screws.

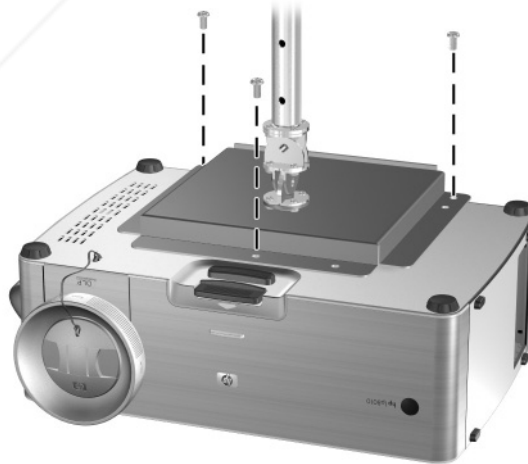

3. Attach the ceiling-mount bracket to the ceiling, and firmly secure with four screws capable of holding 9 kg (20 lb). The ceiling-mount bracket must be located 1.5 to 14 m (5 to 46 ft) in front of the screen.

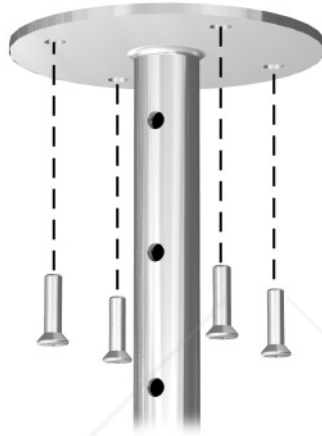

4. Adjust the on-screen menu to match your settings. Open the on-screen menu and select **setup > Projector position**. Then select **Front Ceiling** from the drop-down list.
5. (Optional) Install the cable shroud to hide the cables. See “To install the cable shroud” on page 22. If you secure the projector with a Kensington lock, the lock also secures the shroud.

If you do not use an HP ceiling mount, mount the projector according to the following dimensions:

- X = 176 mm (6.93 in.)
- Y = 188 mm 7.40 in.)
- Z = 86 mm (3.39 in.)
- Thread size = M6

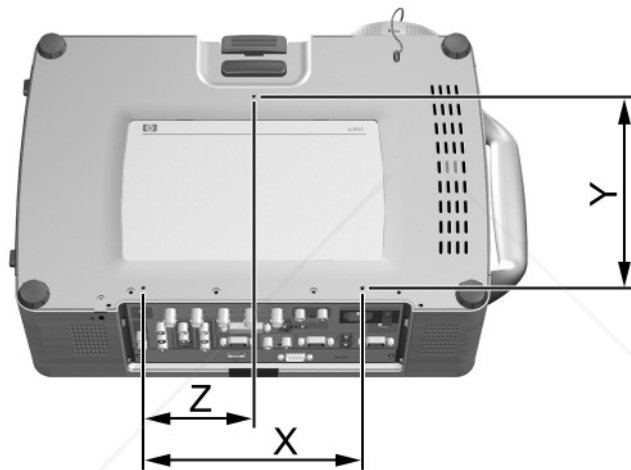

To install for rear projection

1. Place the projector 1.5 to 14 m (5 to 46 ft) behind a translucent screen that is designed for rear projection.

See “To install on a table” on page 18 or “To install on the ceiling” on page 18 for more instructions.

2. Open the on-screen menu and select **setup > Projector position**. Then select **Rear Table** or **Rear Ceiling** from the drop-down list.

If the projector is not visible to the remote control, you can use one of two techniques to enable them to communicate. See “To connect control equipment” on page 33.

To install the cable shroud

You can install the cable shroud to hide cable connections from view.

- Insert the plastic hooks into the upper slots in the projector case, then push the bottom tabs into the lower slots.



Turning On and Off

This section provides the following instructions:

- “To connect power” on page 23
- “To turn the projector on” on page 24
- “To turn the projector off” on page 25
- “To operate the remote control” on page 25
- “To reset the projector” on page 26

To connect power

1. Connect one end of the power cord to the back of the projector **1** and the other end to an electrical outlet **2**.
2. Turn on the main disconnect switch **3** on the back of the projector.



To maintain network connectivity, the main disconnect switch must remain in the on position.



To turn the projector on

1. Be sure the power cord is connected, and the main disconnect switch is turned on.
2. Remove the lens cap by pressing in on the tabs **1** on either side of the lens cap and pulling it straight out **2**.
3. Press the power button **3** on top of the projector, or press the power button on the remote control.

The power button blinks while the projector warms up. When the lamp turns on, the power button stays on, and the projector searches for a signal.

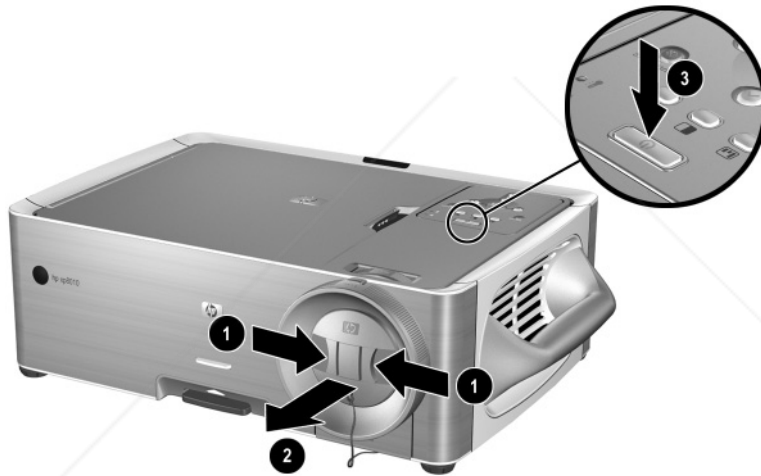

4. Connect and power on the source, such as computer, handheld organizer, or DVD player. See “Making Initial Connections” on page 27 and “Connecting and Preparing” on page 43 for more information.

To turn the projector off

- Press the power button on the projector or remote control to turn off the projector. The power button blinks until the cool-down cycle completes.



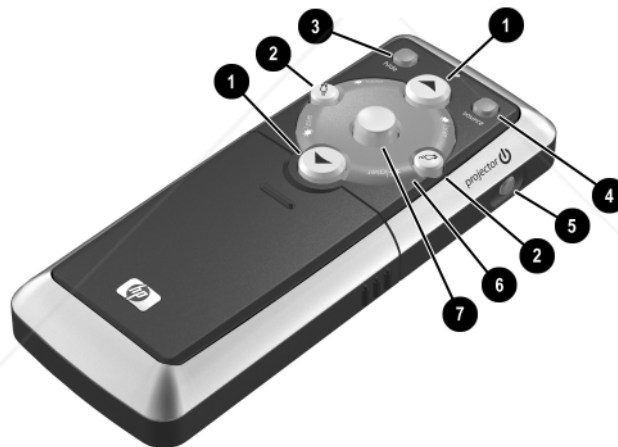

WARNING: Do not unplug the power cord or turn off the main disconnect switch until the cool-down cycle completes and the power button turns off. Failure to follow this precaution can result in damage to the projector.

To operate the remote control



- To turn the project on or off, press the power button ⑤.
- To turn on the laser pointer, hold down the blue laser ring ⑥.
- To hide or unhide the projected picture, press the **hide** button ③.
- To switch to a different connected input source, press the **source** button ④.
- To operate as a mouse on a computer, tilt the mouse button ⑦ to move the pointer, and press the left-click ② or right-click ② button. This feature requires a USB connection between the projector and computer.

- To control page up and page down on a computer, press the page up **1** and page down **1** buttons. This feature requires a USB connection between the projector and computer.
- Slide the remote control case open to use additional buttons.
 - ❑ To optimize the picture for the type of input signal, press the business graphics  or the theatre video  button.
 - ❑ To change projector settings using the on-screen menu, press **enter** and use the navigation buttons to make the changes. See “To change settings using the on-screen menu” on page 34 for more details.
 - ❑ To exit from any on-screen menu or adjustment, press the **back** button one or more times.
 - ❑ To adjust synchronization, press the **auto-sync** button.

For a picture showing the hidden remote control components, see “Remote control” on page 14.



From within a distance of 9 m (30 ft), aim the remote control at the screen or at the front or back of the projector.



WARNING: To reduce the risk of injury to the eyes, do *not* look directly into the remote control laser light, and do *not* point the laser light into anyone’s eyes.

To reset the projector

If the projector becomes completely unresponsive, you can reset all circuits by disconnecting power.

1. Press the power button on the projector or remote control to turn off the projector, then wait until the cool-down period ends and the power button stops blinking. If the projector does not turn off, continue to the next step.
2. Turn the main disconnect switch off and wait 60 seconds. Then turn it on.
3. Press the power button to restart the projector.

Making Initial Connections

If you are a presenter who is setting up the projector for short-term use, see Chapter 3, “Presentations.”

The section explains how to connect different types of equipment to the projector:

- “To connect input sources” on page 27
- “To connect output devices” on page 32
- “To connect control equipment” on page 33

To connect input sources

Computer with VGA cable connection

- VGA cable
- USB A/B cable
- Stereo mini-phone audio cable

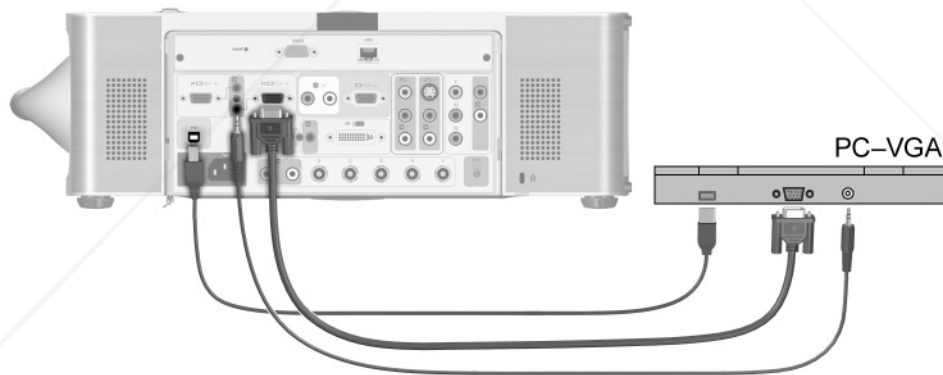

Computer with M1-to-VGA cable connection

- M1-to-VGA/USB cable (available from HP)
- Stereo mini-phone audio cable

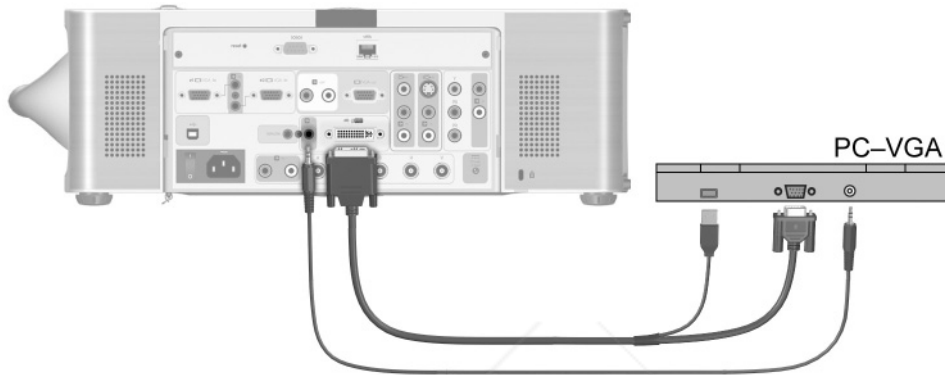

Computer with M1-to-DVI cable connection

- M1-to-DVI/USB cable (available from HP)
- Stereo mini-phone audio cable

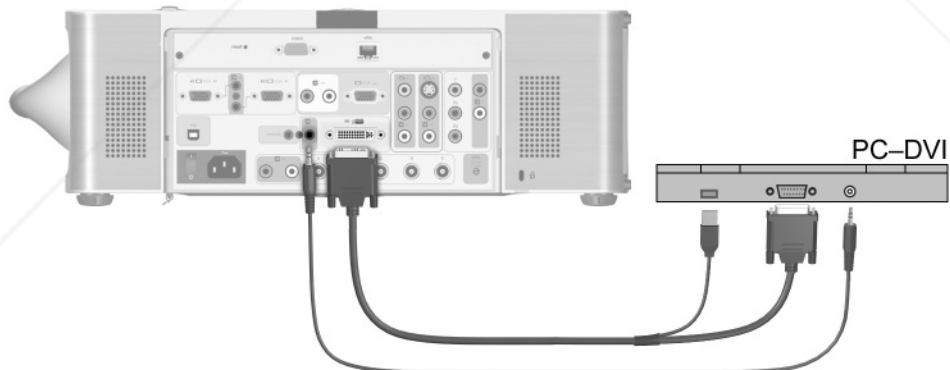

VCR with composite video cable connection

- Video-RCA cable
- Stereo-audio RCA cable

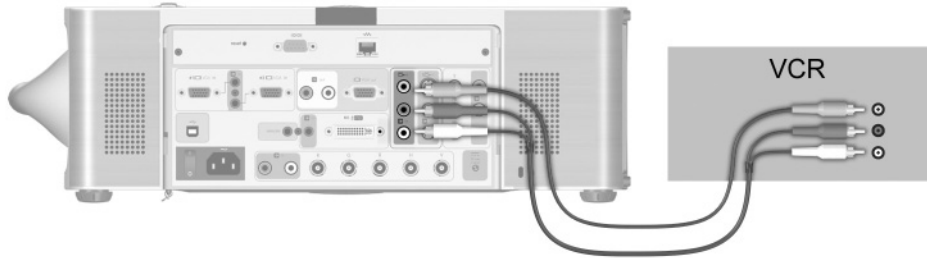

S-video equipment connection

- S-video cable
- Stereo-audio RCA cable

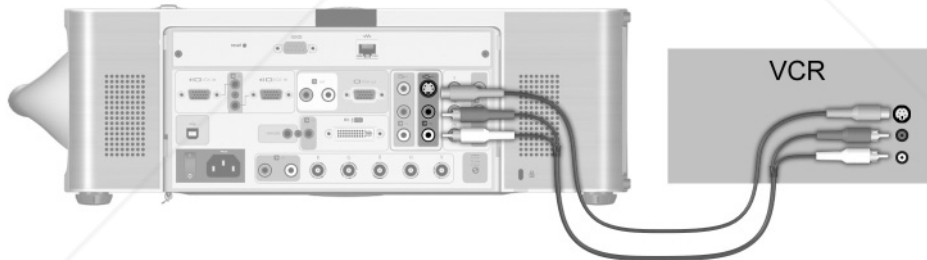

DVD or HDTV with component-video cable connection

- YPbPr RCA cable
- Stereo-audio RCA cable

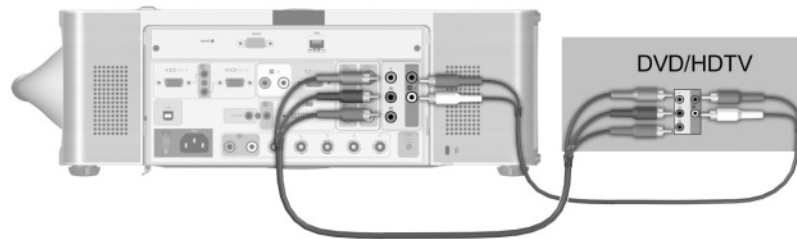

SCART-device connection

- M1-to-SCART adapter cable (available from HP)
- SCART cable
- Stereo mini-phone audio cable

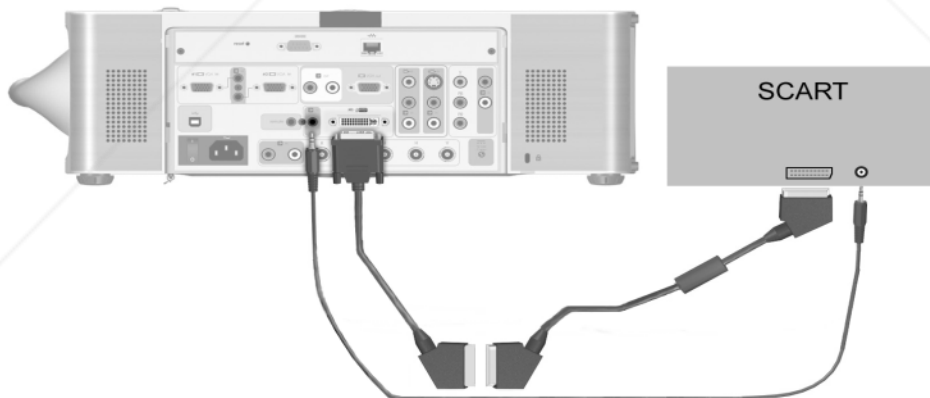

RGB-equipment connection

- RGB-video BNC cable
- Stereo-audio RCA cable



RGBS-equipment connection

- RGBS-video BNC cable
- Stereo-audio RCA cable

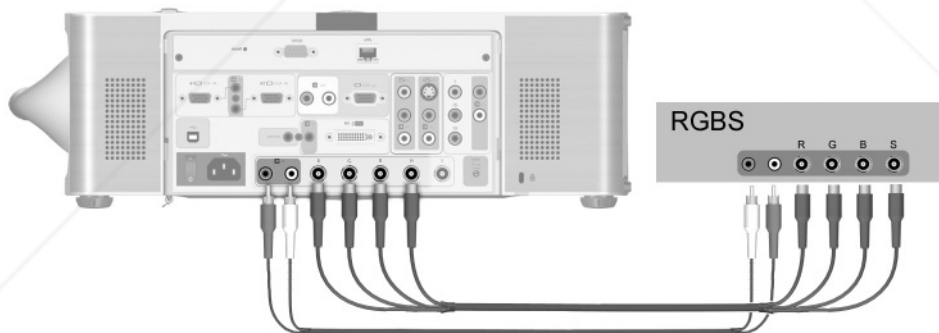

RGBHV-equipment connection

- RGBHV-video BNC cable
- Stereo-audio RCA cable

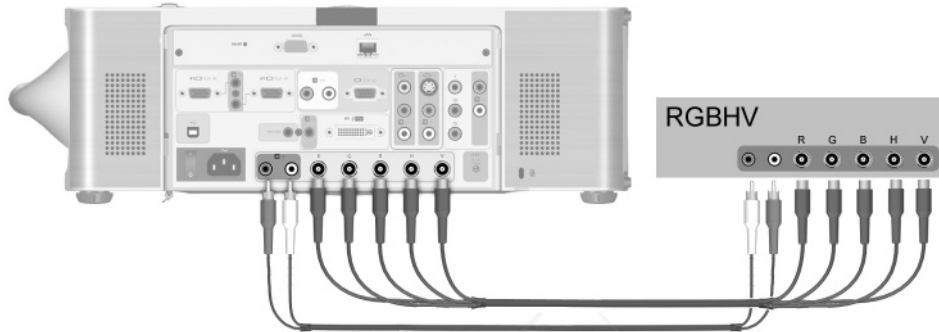

To connect output devices

- VGA cable
- Stereo-audio RCA cable

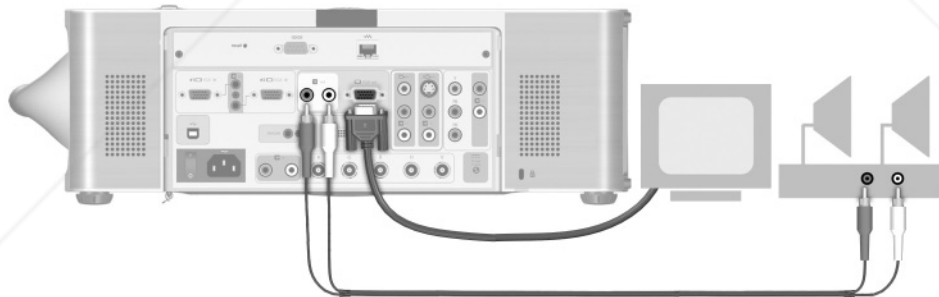

The speakers must be amplified.

To connect control equipment

- 9-pin serial cable
- 2.5-mm (3/32-in) to 3.5-mm (1/8-in) stereo mini-phone cable
- 3.5 × 1.3-mm DC power cable

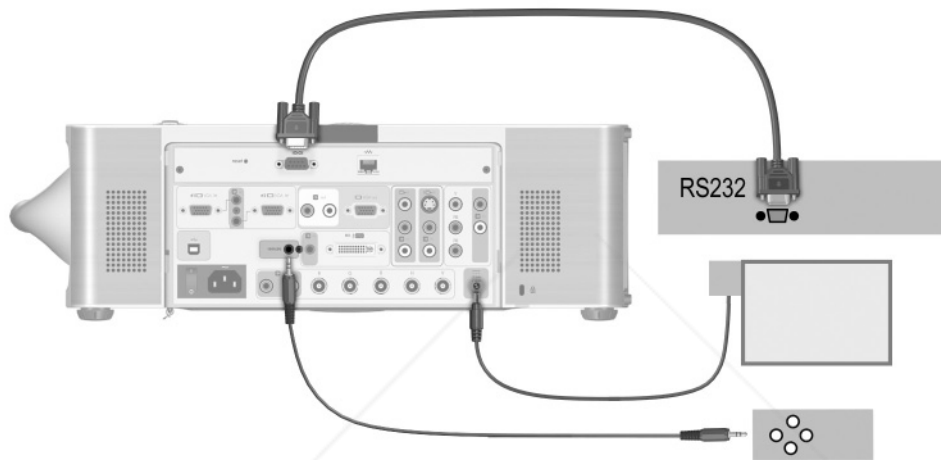

In some installations, the projector might not be visible to the remote control, such as for rear projection. Use one of these solutions to enable the remote control to work:

- Use a remote control extension. Plug its cable into the remote connector on the projector. Install the receiver in the room with the presenter.
- Wire the remote control to the projector. Construct a cable with a 2.5-mm (3/32-in) stereo mini-phone jack at one end and a 3.5-mm (1/8-in) stereo mini-phone jack at the other end. Plug the small connector into the remote control and the large connector into the remote connector on the projector.

Configuring the Projector

To change settings using the on-screen menu

You can change the on-screen menu settings with either the buttons on the projector or the remote control buttons.

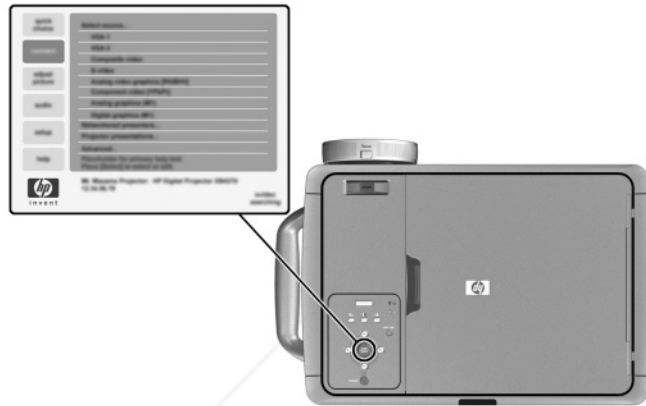

1. Press **enter** on the projector or the remote control to open the on-screen menu.
2. Press **▲** up or **▼** down to highlight the desired menu, and press **enter** to select the highlighted option.
3. Press **▲** up or **▼** down to highlight the desired parameter, and press **enter** to select the highlighted option.
4. Press **◀** left or **▶** right or press **▲** up or **▼** down to select the desired setting. For certain parameters, you see a different display while making the change.
5. Press **enter** to return to the menu.
6. To go to a different menu, press the **back** button, and select the menu.
7. To close the on-screen menu, press the **back** button one or more times as needed.

If nothing occurs for a period of time, the on-screen menu closes. To change the amount of time until the on-screen menu closes, open the on-screen menu and select **setup > Timeout**.

See “Using the On-Screen Menu” on page 61 for a list of all on-screen menu selections.

To set up network access

1. Plug a CAT5 network cable into the RJ-45 network port on the back of the projector.

If the projector has power, the left indicator light on the network port turns on showing a 10- or 100-Mb/s connection. The light on the right shows network activity.

The projector normally attempts to get an IP address from a Dynamic Host Configuration Protocol (DHCP) server, or, if a server is not available, it takes a default address. The IP address is displayed at the bottom of the on-screen menu.

2. If you want to view or change the projector's TCP/IP network configuration, turn on the projector, open the on-screen menu, select **setup > Network**, and enter changes. If you are not running on a DHCP server, talk to your network administrator to find the correct TCP/IP network settings.

To set the advanced network configuration, see “To set basic projector properties” on page 54.



Securing the Projector

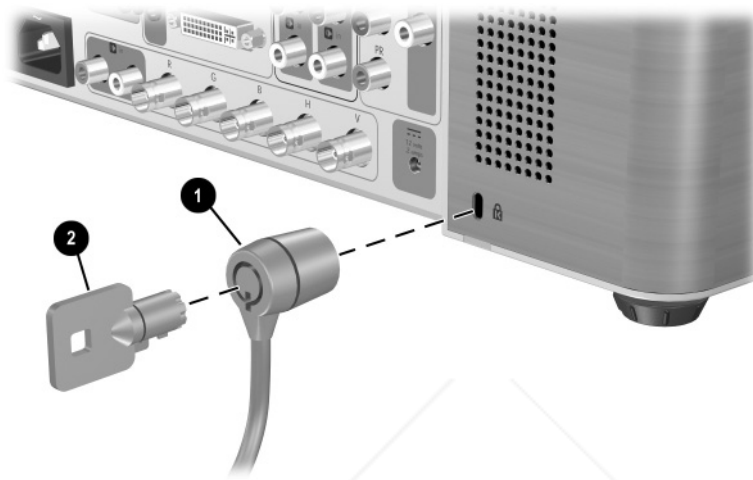

The projector includes a built-in slot to secure the projector with a cable and a lock (such as the Kensington MicroSaver lock system, available at many computer stores).

1. Wrap the cable around a secure object, such as a table leg. Loop the cable to create a slip knot around the stationary object, and be sure it cannot slip off.
2. Insert the lock ❶ into the hole and twist the key ❷.

If the cable shroud is installed on the projector, the lock secures the shroud and the projector.

Adjustments

This chapter describes how to make adjustments to the projector. The chapter covers:

- “Making Basic Adjustments” on page 37.
- “Adjusting the Picture” on page 40.

Making Basic Adjustments

This section provides the following instructions:

- “To aim the projector” on page 38
- “To adjust the focus and zoom” on page 39
- “To adjust the audio” on page 39

To aim the projector

- To raise the projected picture on the screen, raise and hold the height adjustment lever while lifting the front of the projector to the desired display angle, then release the lever to lock the foot.



- To lower the projected picture, raise and hold the height adjustment lever while pressing down on the front of the projector, then release the lever to lock the foot.
- To level the projected picture, turn the two back feet to screw in or out. All four feet are adjustable in this way.

To adjust the focus and zoom

1. Rotate the focus ring **1** until the image becomes clear. The projector can focus at distances of 1.5 to 14 m (5 to 46 ft).
2. Rotate the zoom ring **2** to adjust the picture size from 100 to 120%.

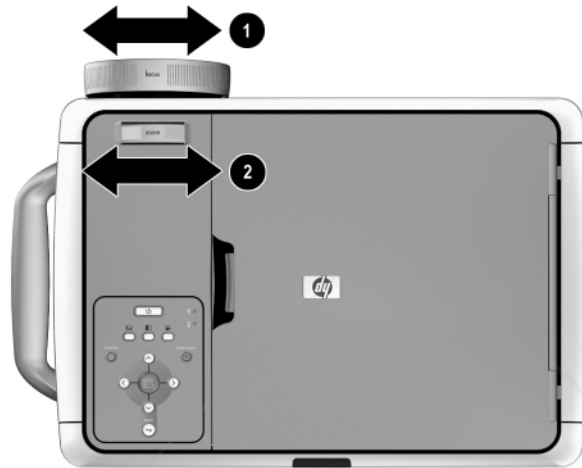

See “Selecting a Location” on page 17 for more information.

To adjust the audio

1. Open the on-screen menu and select **audio**.
2. Set the audio adjustments.

From the audio menu, you can select audio inputs, turn off internal speakers, and adjust mute, volume, balance, treble, and bass.

To get descriptions for all available audio adjustments, see “Using the On-Screen Menu” on page 61.



Adjusting the Picture

This section provides the following instructions:

- “To adjust the image according to type of picture” on page 40
- “To adjust other image settings” on page 40
- “To make adjustments from the web” on page 41

To adjust the image according to type of picture

Use the picture mode buttons on the projector or the remote control to optimize the image.

- To optimize the picture for data presentations, press the business graphics  button.
- To optimize the picture for video images, press the theatre video  button.
- To maximize brightness, press the super-bright  button (not available on the remote control). With this mode, the image is displayed in black and white.

To adjust other image settings

The on-screen menu provides many settings that allow you to fine-tune the picture.

1. Open the on-screen menu and select **adjust picture**.
2. Change the picture adjustments as needed.

From the adjust picture menu, you can change basic and advanced picture options, such as brightness, contrast, white intensity, aspect ratio, and keystone correction.

To get descriptions for all available picture adjustments, see “Using the On-Screen Menu” on page 61.



To exit from any on-screen menu or adjustment, press the **back** button one or more times.

To make adjustments from the web

If you have a computer with internet access, you can adjust the projector without opening the on-screen menu. The web interface has been tested on Microsoft Windows 2000 and XP, Mac OS 9 and 10, Internet Explorer 5.5 and above, and Netscape Navigator 7.0 and above.

1. On a networked computer, open an internet browser, enter the IP address of the projector into the URL bar, and press the **Enter** key. See “To find the IP address” on page 53 for more information.
2. Click the **Projector** tab. On the left side of the screen, click **adjust picture**.
3. To adjust picture settings, select one or more of the options that are displayed on the right side of the screen, and click **Apply**.

Depending on access permission, you can change all projector settings from your computer browser.



Discount-Merchant.com (800) 281-8860

THE TRUSTED SOURCE FOR PROJECTOR LAMPS AND ACCESSORIES

Presentations

The chapter explains how to temporarily connect computers and other devices to the projector. This chapter covers:

- “Connecting and Preparing” on page 43.
- “Showing Presentations” on page 49.
- “Disconnecting” on page 51.

Connecting and Preparing

The section provides the following instructions:

- “To connect a computer using a VGA cable” on page 44
- “To connect a handheld organizer” on page 45
- “To connect a computer using other types of cables” on page 46
- “To connect other video sources” on page 48

For information about other types of connections, see “Making Initial Connections” on page 27.

To connect a computer using a VGA cable

1. Connect a standard VGA cable between the VGA #1 port on the projector **1** and the VGA port on the computer **2**.
2. (Optional) To allow the remote control to function as the computer mouse, connect a USB A/B cable between USB-out port on the projector **3** and the computer **4**.
3. (Optional) To get audio, connect a mini-stereo cable between the VGA #1 audio port on the projector **5** and the computer **6**.



For a desktop computer, you can plug the desktop monitor into the VGA-out port on the projector, so the picture is visible on the projector screen and the desktop monitor.

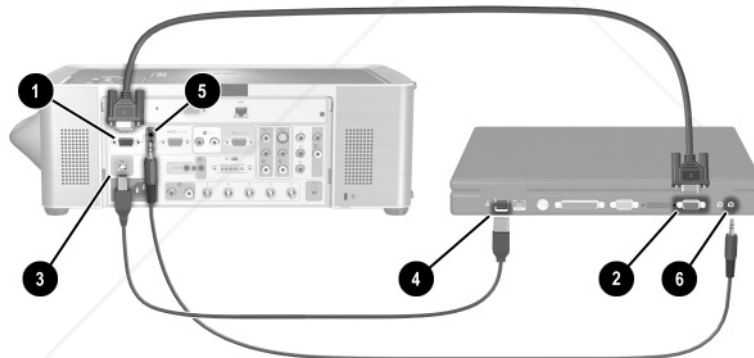

To connect a handheld organizer

1. Be sure the handheld organizer has a VGA-out port. If necessary, install a VGA-out accessory card into the organizer.



Not all handhelds come with VGA-out ports. For example, the iPAQ Pocket PC requires a VGA-out PC Card with 15-pin connector.

2. Connect a standard VGA cable between the VGA #1 port on the projector **1** and connect the other end to the VGA-out PC Card **2**.



To connect a computer using other types of cables

M1 to VGA/USB connection

1. Connect an M1-to-VGA/USB cable (available from HP) between the M1 port on the projector **1** and the VGA port on the computer **2**.
2. (Optional) To allow the remote control to function as the computer mouse, connect the USB plug of the M1-to-VGA/USB cable into the USB port on the computer **3**.
3. (Optional) To get audio, connect a stereo mini-phone cable between the M1-audio port on the projector **4** and the computer **5**.

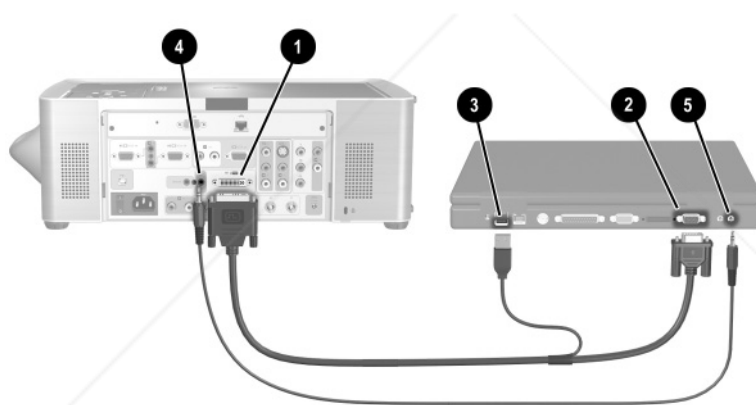

M1 to DVI/USB connection

1. Connect an M1-to-DVI/USB cable (available from HP) between the M1 port on the projector **①** and the DVI port on the computer **②**.
2. (Optional) To allow the remote control to function as the computer mouse, connect the USB plug of the M1-to-DVI/USB cable into the USB port on the computer **③**.
3. (Optional) To get audio, connect a stereo mini-phone between the M1-audio port on the projector **④** and the computer **⑤**.

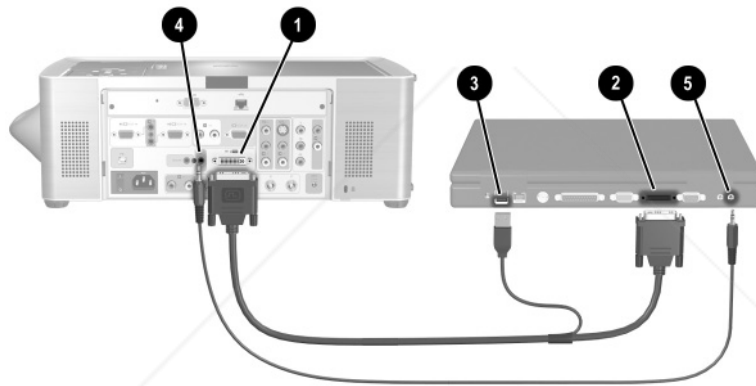

To connect other video sources

DVD player connection

1. Connect a triple RCA cable between the YPbPr ports on the DVD player **1** to the YPbPr ports on the projector **2**. Observe the color coding of the connectors.
2. (Optional) To get audio, connect a stereo RCA cable between the stereo-audio ports on DVD player **3** and the YPbPr audio ports on the projector **4**. Observe the color coding of the connectors.

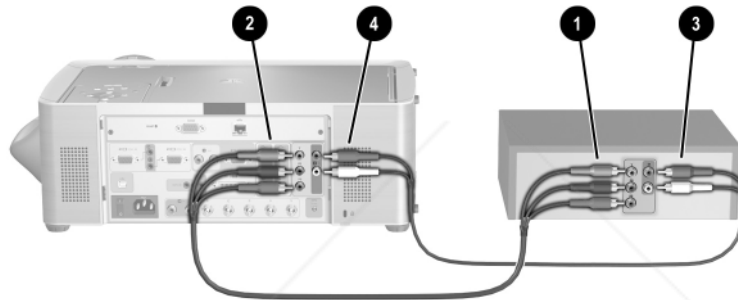

VCR connection

1. Connect a composite-video cable between the composite-video connector on the VCR **1** and the projector **2**.
2. (Optional) To get audio, connect an RCA cable between the stereo-audio ports on VCR **3** and the composite-audio ports on the projector **4**. Observe the color coding of the connectors.

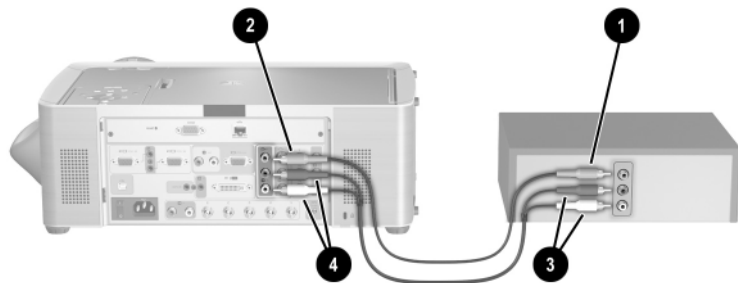

Showing Presentations

The following section describes several things you can do during presentations:

- “To present from a computer” on page 49
- “To change the source” on page 50
- “To hide or show the display” on page 50

To present from a computer

1. Be sure the computer is connected to the projector. See “Connecting and Preparing” on page 43 for more information.
2. Be sure the computer and the projector are on. See “To turn the projector on” on page 24 for more information.



If the computer display is not projected on the screen, you might have to press a function key (such as **Fn + F4**) to turn on the computer’s video port. See the video port card shipped with the projector.

3. If you want to adjust the projected image, see “Adjusting the Picture” on page 40.
4. You can use the remote control to enhance your presentation. For more information, see “To operate the remote control” on page 25.
 - To page through a presentation, press the **^** page-up or **v** page-down buttons.
 - To move the mouse pointer, tilt the mouse button.
 - To turn on the laser pointer, hold down the laser ring.



WARNING: To reduce the risk of injury to the eyes, do *not* look directly into the remote control laser light, and do *not* point the laser light into anyone’s eyes.



For the mouse and **^** page-up or **v** page-down operations, aim the remote control at the screen or at the front or back of the projector from within a distance of 9 m (30 ft).

These operations require a USB connection from the projector to the computer.

To change the source

- Press the **source** button on the projector or remote control, or
- Open the on-screen menu, select **input**, and select the port to which the input source is connected.

To hide or show the display

You can easily hide the display from your audience temporarily.

- Press the **hide** button on the remote control. The screen remains blank until you press the **hide** button again.



If you are using Microsoft PowerPoint, you can also press the **B** key or the **W** key to hide the display. The screen remains blank until you press the **B** key or the **W** key again.

Disconnecting



CAUTION: Do *not* disconnect power or turn off the projector until the projector has cooled down (the fan stops) and the power button light stops blinking. Otherwise, you might shorten the life of the lamp.

1. Press the power button on the projector or remote control to turn off the projector. The power button blinks during the two-minute cool-down period. Then, the projector enters Standby mode, which retains network connectivity.
 2. You can disconnect video and audio equipment from the projector during the cool-down period but not the power cord.
-



If the projector is connected to a network, do *not* turn off the main disconnect switch or unplug power. Disconnecting the power breaks the network connection.

3. If you must unplug or remove the projector, wait until the power button light stops blinking. Then turn off the main disconnect switch on the back of the projector and unplug the power cord.

If you try to turn on the projector again during the cool-down period, it does not turn on. Wait until the cool-down period ends and the power button stops blinking.



Discount-Merchant.com (800) 281-8860

THE TRUSTED SOURCE FOR PROJECTOR LAMPS AND ACCESSORIES

System Management

This chapter explains how you can manage one or more projectors. If the projector is connected to a network, you can work from a central location by accessing the projector's embedded web server, rather than being in the same room as the projector. You can check the projector's current status, change its configuration, program automatic shutdown times, and upgrade firmware—all from a remote location.

The web interface has been tested on Microsoft Windows 2000 and XP, Mac OS 9 and 10, Internet Explorer 5.5 and above, and Netscape Navigator 7.0 and above.

This chapter covers:

- “Managing the Projector” on page 53.
- “Upgrading the Projector” on page 56.

Managing the Projector

This section provides the following instructions:

- “To find the IP address” on page 53
- “To set basic projector properties” on page 54
- “To set up email for notifications” on page 55
- “To protect configuration changes” on page 55

To find the IP address

- Press **enter** on the projector or remote control to open the on-screen menu. Record the IP address, shown as a series of numbers on the bottom of the menu.

Press the **back** button to close the menu.

To set basic projector properties

1. On a networked computer, open an internet browser, enter the IP address of the projector in the URL bar, and press **Enter**. See “To find the IP address” on page 53 for more information.
2. Depending on the property you want to view or change, go to the location indicated in the following table.
3. Make any necessary changes and click **Apply**.

Changing Projector Properties

Projector Property	Location in Web Interface
Status	Home > Device Info
Web interface language	Home > Select Language
Picture and audio*	Projector
Basic network configuration*	Networking > TCP/IP (or Wired Settings on certain models)
Advanced network configuration	Networking

*These properties are also available in the on-screen menu.

To set up email for notifications

The projector can send email messages to specified recipients when certain critical events occur.

1. On a networked computer, open an internet browser, enter the IP address of the projector into the URL bar, and press **Enter**. See “To find the IP address” on page 53 for more information.
2. Click the **Management** tab, and on the left side of the screen, click **Alerts**.
3. Select one or more of the events that cause email alerts.
4. Enter the email addresses to receive the alerts.
5. Enter the IP address of the Simple Mail Transfer Protocol (SMTP) server used by the projector for outgoing email. The SMTP server relays messages to recipients.
6. Click **Apply**.

To protect configuration changes

1. On a networked computer, open an internet browser, enter the IP address of the projector into the URL bar, and press **Enter**. See “To find the IP address” on page 53 for more information.
2. Click the **Networking** tab, and on the left side of the screen, click **Admin Account**.
3. Enter and confirm a password.
You must use this password for all access and configuration parameter changes. To disable the password, delete the password and leave the field blank.
4. Click **Apply**.

Upgrading the Projector

The section provides the following instructions:

- “To update the firmware” on page 56
- “To install an add-on lens” on page 57
- “To change the connectivity module” on page 59

To update the firmware

HP might periodically release updated versions of the projector firmware to enhance the projector performance. The projector firmware version is shown in the on-screen menu at **help > About this projector** and in the web interface on the **Home** tab. Check for updated versions at http://www.hp.com/go/proj_firmware.

Web Method

1. On a networked computer, open an internet browser, enter the IP address of the projector in the URL bar, and press the **Enter** key. See “To find the IP address” on page 53 for more information.
2. If the projector is turned on, press the power button to turn it off. Or you can do this in the browser by clicking the **Projector** tab, then clicking the Power button.
3. Click the **Management** tab, and on the left side of the screen, select **Firmware Upgrade**.
4. Click the link for finding upgrade files on the web, then download the latest upgrade file.
5. Return to the projector **Firmware Upgrade** page and click **Browse**. Then, select the file you downloaded.
6. Click the upgrade button to start the upgrade process. Follow the displayed instructions.

To install an add-on lens

If the projector distance and image size are not compatible with the room configuration, an add-on lens might provide a solution.

Use the following table to coordinate distance to the screen, width of the screen, and lens size.

Identifying lens range

Lens	Distance	Distance/Width Ratio
Short-throw lens	1.5–12 m (5–40 ft)	1.56–1.88
Normal lens	1.5–14 m (5–46 ft)	1.98–2.38
Long-throw lens	1.5–18 m (5–60 ft)	2.35–2.81

1. Be sure the lens cover is removed.
2. Turn the focus ring fully counter-clockwise.

3. Press and hold the release latch on the focus ring **1**, and turn the ring **2** fully counterclockwise until it stops, and pull off the ring **3**.

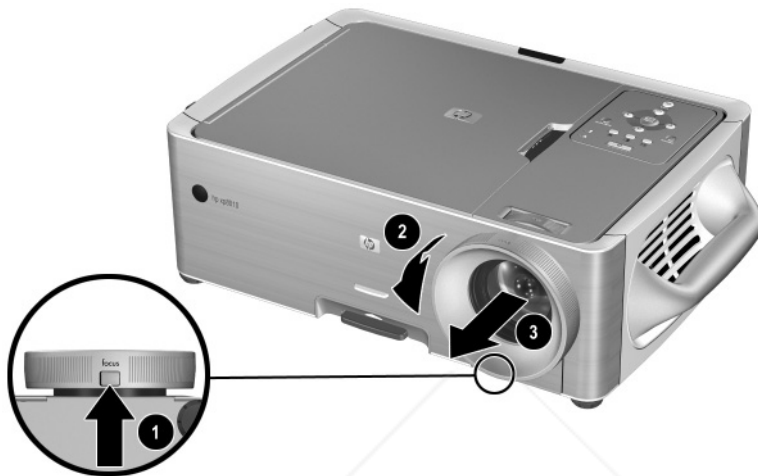

4. Line up the marks on the lens and projector. Insert the add-on lens **1** into the slots on the main lens, then turn the lens **2** fully clockwise until the lens clicks into place.



To change the connectivity module

1. Turn off the projector and disconnect power.
 2. Open the lid ❶.
 3. Remove the screw directly behind the back infrared receiver ❷.
 4. Loosen the two screws ❸ on the faceplate of the connectivity module at the back of the projector.
 5. Use the screws to pull the module out of the projector ❹.
- Reverse the procedure to install the connectivity module.

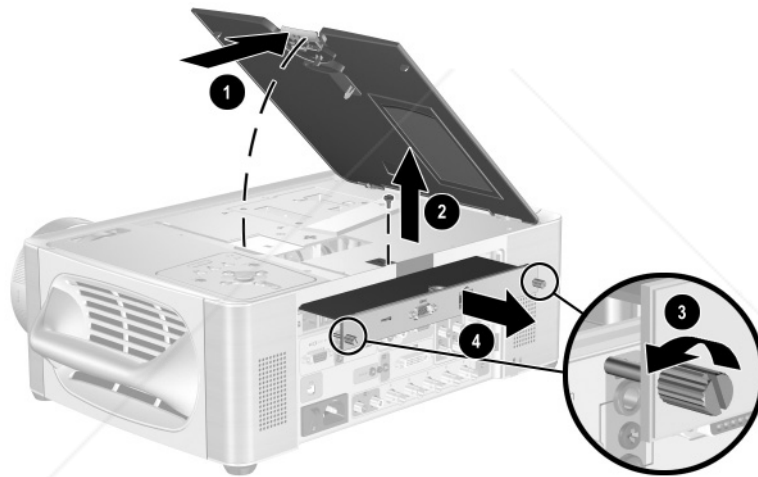



Discount-Merchant.com (800) 281-8860

THE TRUSTED SOURCE FOR PROJECTOR LAMPS AND ACCESSORIES

Maintenance

This chapter explains how to maintain the projector. The chapter covers:

- “Using the On-Screen Menu” on page 61.
- “Performing Routine Maintenance” on page 68.

Using the On-Screen Menu

The following tables describe all the functions available in the on-screen menu for the firmware version at publication. If your firmware is a different version, some menus might differ from those shown.

- “Quick Choice menu” on page 62
- “Input menu” on page 62
- “Adjust Picture menu” on page 64
- “Audio menu” on page 66
- “Setup menu” on page 66
- “Help menu” on page 67



To exit from any on-screen menu or adjustment, press the **back** button one or more times.

Quick Choice menu

This menu provides quick access to commonly used functions from other menus. The menu in your projector may differ from the menu shown below.

quick choice

Brightness	Brightens or darkens the image.
Contrast	Sets the difference between light and dark areas.
Keystone correction	Corrects the slanted edges of an image. This function compensates for an off-center projector location.
Reset keystone correction	Resets the keystone correction to zero.
Hide	Removes all images from the screen.

Input menu

This menu was named the **Connect** menu in earlier firmware versions. For a visual aid, see “Back panel” on page 12.

input

VGA #1	Shows the input to the VGA #1 port. The VGA #1 usually connects the projector to a computer. This port usually connects to a computer. This input is normally considered a graphics input.
VGA #2	Shows the input to the VGA #2 port. The VGA #2 usually connects the projector to a computer. This port usually connects to a computer. This input is normally considered a graphics input.
Composite video	Shows the input to the yellow composite port (the input to the left of the S-video port on the back panel). The port usually connects to TV or VCR. This input is normally considered a video input.

input (continued)

S-video	Shows the input to the S-video port. This usually connects to a video device, such as a VCR, camcorder, or DVD player. This connection is normally considered a video input.
Component video (YPbPr)	Shows the input to the three-connector YPbPr port. This connects to a high-quality video device, such as a DVD player.
Analog video (RGBHV)	Shows the input to the five-connector RGBHV port. This usually connects to an analog graphics device with 3, 4, or 5 connectors. Automatically detects the signal type: RGB, RGBS, RGBHV, YPbPr, YCbCr. This connection is normally considered a graphics input.
Digital/analog graphics (M1)	Shows the digital or analog input to the M1 port. This port connects to several types of devices, including analog VGA and SCART devices and digital DVI (Digital Video Interface) devices. This connection is considered graphics or video input, depending on the device.
Source auto-search	Sets whether the projector automatically searches for input signals and displays the next one found.

Adjust Picture menu

adjust picture

Picture mode	Adjusts the color palette according to the type of picture. You can optimize the picture for computer presentations, video output, or super-bright grayscale output. The remote control and projector have buttons to change the picture mode.
White intensity	Sets the brightness of white areas.
Brightness	Brightens or darkens the image.
Contrast	Sets the difference between light and dark areas.
Color space	For certain component inputs, selects the type of signal encoding used by the input source. You can override the selection made by the projector.
Keystone correction	Corrects the slanted edges of an image. This function compensates for an off-center projector location.
Reset keystone correction	Resets the keystone correction to zero.
Aspect ratio	Selects proportions of the image. <ul style="list-style-type: none">• To automatically adapt to most inputs, select Best fit.• If a wide-screen picture seems stretched, select 16:9.• To stretch the picture to cover the entire projection area, select Fill.• To show each picture dot as one projected dot, select 1-to-1.
Magnify	Enlarges a portion of the picture, so it fills the entire screen.
Advanced picture >	Adjusts the advanced picture settings.
Color saturation	Adjusts the intensity of colors.

adjust picture *(continued)*

Tint	Shifts colors toward red or green.
Sharpness	Sharpens or softens the image.
Color temperature	Shifts colors toward red or blue.
Auto-sync	Resynchronizes the projector to the input signal. This can compensate for any change in the signal.
Vertical position	Shifts the image up or down within the projection area.
Horizontal position	Shifts the image left or right within the projection area.
Frequency	Adjusts the timing of the projector relative to a computer graphics card.
Tracking	Synchronizes the projector to a computer graphics card.
Reset video settings	Resets the video settings to their default settings.

Audio menu

audio

Mute	Stops the audio output.
Volume	Changes the loudness of the audio.
Balance	Changes the loudness of the left and right audio.
Treble	Changes the loudness of the higher frequencies.
Bass	Changes the loudness of the lower frequencies.
Audio input select	Selects the audio input source, independent of the video source.
Internal speakers	Sets whether the built-in speakers are active. Useful when the audio output is connected to an external audio system.
Reset audio settings	Resets the audio settings to the default values.

Setup menu

setup

Language	Selects the language for the menus.
Lamp saver	Sets a lower light output for longer lamp life.
Projector position	Adjusts the image to match the orientation of the projector: upright or upside-down, in front of or behind the screen. Inverts or reverses the image accordingly.
Enable sources	For each input source, sets whether it is searched or ignored when the projector searches for an input.
Timeout for menu	Sets how long the on-screen menu waits for input before it closes.

setup (continued)

Network >	Sets up the TCP/IP network parameters. Check with the network administrator.
DHCP	Sets whether a DHCP server is used to assign an IP address to the projector. Do not use DHCP if you want the projector to have a fixed IP address every time power is connected.
IP address	Sets the projector IP address if not using DHCP.
Subnet mask	Sets the projector subnet mask if not using DHCP.
Gateway	Sets the projector gateway address if not using DHCP.
Reset lamp hours	For a new lamp, resets hours of use.
Machine reset	Resets most of the menu settings to default.

Help menu**help**

About this projector	Displays information and status for the projector.
Diagnostics	Show tests for checking the operation of the projector and the remote control.

Performing Routine Maintenance

This section provides the following instructions:

- “To get the projector status” on page 68
- “To clean the projector lens” on page 68
- “To replace the lamp module” on page 69
- “To replace the battery in the remote control” on page 70

To get the projector status

- Open the on-screen menu and select **help > About this projector**. This screen shows information and status for the projector.

To clean the projector lens

- To minimize the risk of damaging or scratching the lens surface, blow dust particles off the lens with clean, dry, deionized air.

If this method does not work, use the following method:

- Wipe the lens in a single direction with a clean, dry cloth. Do not wipe back and forth across the lens.

If the cloth is dirty or smears the lens, wash the cloth. If the cloth is still dirty after washing it or the fabric is damaged, replace it.



CAUTION: Cleaning requires special consideration:

- Do not spray any type of fluid or cleaner directly on the lens surface. Cleaners might damage the lens.
- Do not use fabric softener when washing a cleaning cloth or softener sheets when drying the cloth. Chemicals on the cloth might damage the surface of the lens.
- Do not store a cleaning cloth in contact with the lens for a long time because doing so contaminates the lens with dye from the cloth. The cloth can be contaminated if left in the open air.

To replace the lamp module



WARNING:

- When the lamp nears its end of life, it might break. To reduce the risk of injury, be careful when removing the lamp cover as broken glass might be present. For a ceiling installation, wear goggles and gloves when removing the lamp module. If the lamp is broken, contact HP about repairs that might be required.
- Wait 30 minutes before opening the lamp cover and removing the lamp module because the lamp assembly operates at a very high temperature. If you open the lid during cool-down, you increase the cool-down time because the lid safety switch disconnects power and turns off the fan.

1. Turn off the projector and allow it to cool for 30 minutes.
2. Open the lid ❶ on the top of the projector.
3. Use a Phillips screwdriver to loosen the three screws ❷ holding the lamp module.
4. Lift the handle ❸ and unplug the lamp module ❹ from the projector.

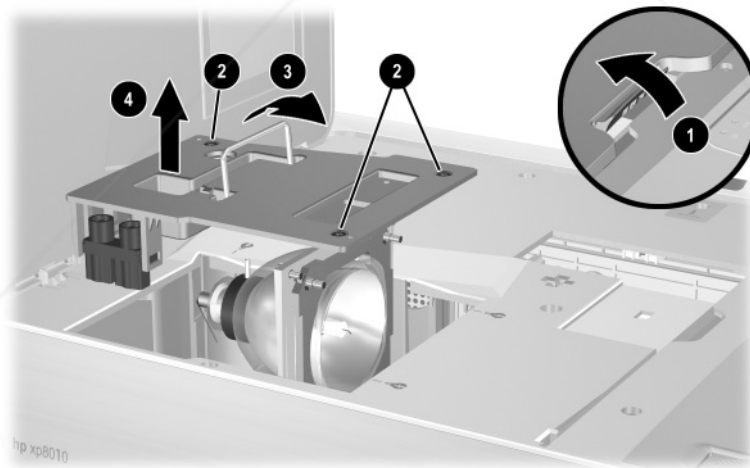

CAUTION: Do not touch any internal parts of the projector. You could easily damage delicate or precision parts.

5. Insert the new lamp module and tighten the three screws.

6. Close the lid.
7. Turn on the projector. If the lamp does not turn on after the warm-up period, try reinstalling the lamp again.
8. Open the on-screen menu and select **setup > Reset lamp hours**.



WARNING: The lamp contains a small amount of mercury. If the lamp breaks, adequately ventilate the area where the breakage occurred. Disposal of this lamp may be regulated due to environmental considerations. For disposal or recycling information, please contact your local authorities or the Electronic Industries Alliance (www.eiae.org).

To replace the battery in the remote control

1. Slide the remote control case open to reveal the battery compartment.
2. On the back of the remote control remove the battery cover ❶ to reveal the batteries.
3. Remove the old batteries, and install two new AAA batteries ❷.
4. Install the battery cover.

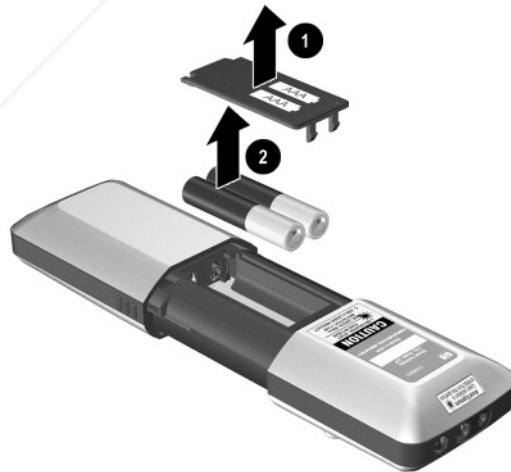

When discarding old batteries, contact your local waste-disposal provider regarding local restrictions on the disposal or recycling of batteries.

Troubleshooting

This chapter describes potential problems and offers suggestions to help correct them. This chapter covers:

- “Troubleshooting Suggestions” on page 71.
- “Testing the Projector” on page 81.

Troubleshooting Suggestions

To use this section, find the problem statement that is closest to your problem, then try each bulleted item one at a time until your problem is fixed. If the suggestions do not solve your problem, contact HP. See the *Support Guide* included with the projector.

This section covers:

- “Start-up problems” on page 72.
- “Picture problems” on page 73.
- “Sound problems” on page 77.
- “Interruption problems” on page 78.
- “Remote control problems” on page 79.
- “Networking problems” on page 79.

Start-up problems

If no lights or sounds turn on:

- Ensure that the power cable is securely connected to the projector and the other end is plugged into an outlet with power.
- Verify the main disconnect switch is turned on (1), not off (0).
- Verify that lid of the projector is latched shut.
- Press the power button again.
- Reset the projector by turning the main disconnect switch off, wait 60 seconds, then turn it on again.

If nothing is projected, but the projector seems to start up:

- Ensure the lens cap has been removed.
- If the lamp indicator is on, replace or reinstall the lamp module.
- If the temperature indicator is on, turn off the projector and allow it to cool before restarting it. If the warning lights turn on again, contact HP for assistance.

If the projector makes a “ticking” sound, if the projector lamp does not turn on, and if warning lamp light is on:

- The projector lamp is too hot to light. Turn the projector off and wait for it to cool before turning it on again.
- The projector lamp is not making a good connection. Turn off the projector and allow it to cool. Then remove and reinstall the lamp module.
- The projector lamp has reached the end of its life. Replace the lamp.

Picture problems

If the image is not displayed on the screen, but the HP startup screen is displayed:

- Press the **source** button on the projector or remote control.
- Turn off or disable the notebook or desktop computer screen saver function.
- For a computer connection, ensure your notebook computer's external video port is turned on. See the video port card shipped with the projector. On some notebooks, for example, press the **Fn + F4** function keys to turn on the external video port.
- Verify that the right input source is connected. Open the on-screen menu and select **input**. Then set the correct input source where the equipment is connected.
- Verify that the input port is enabled for auto-searching. Open the on-screen menu and select **setup > Enable sources**.
- Verify that auto search is enabled. Open the on-screen menu and select **input > Source auto-search**.

If the wrong input source is displayed:

- Press the **source** button on the projector or the remote control to select another active input source.
- Verify that the right input source is connected. Open the on-screen menu and select **input**. Then set the correct input source.
- Verify that the input port is enabled for auto-searching. Open the on-screen menu and select **setup > Enable sources**.
- Verify that auto search is enabled. Open the on-screen menu and select **input > Source auto-search**.

If the image is out of focus:

- Ensure the lens cap is removed.
- While displaying the on-screen menu, adjust the focus ring. (The image size should not change; if it does, you are adjusting the zoom not the focus.)

- ❑ Ensure the projection screen is 1.5 to 14 m (5 to 46 ft) from the projector. It can be farther if a long range add-on lens is installed.
- ❑ For a computer connection, set the display resolution on the computer to 1024 x 768.
- ❑ Check the projection lens to see if it needs cleaning.

If an upside-down or reversed image is displayed:

- ❑ The projector has been set to the wrong position setting. Open the on-screen menu, select **setup > Projector position**, and choose the correct setting

If the image is too small or too large:

- ❑ Adjust the zoom ring on top of the projector.
- ❑ Ensure the projector is 1.5 to 14 m (5 to 46 ft) from the projection screen.
- ❑ Open the on-screen menu and select **adjust picture > Aspect ratio**. Set to **Best fit**. For a wide-screen picture, try setting the aspect ratio to **16:9**.
- ❑ See “To install an add-on lens” on page 57 for more information.

If the image has slanted edges:

- ❑ As much as possible, reposition the projector so that it is centered on the screen and level with the bottom or top of the screen.
- ❑ Open the on-screen menu and select **adjust picture > Keystone correction**. Adjust the horizontal and vertical settings as needed.

If a scrolling or cut-off image is displayed:

- ❑ Press the **auto sync** button on the projector or remote control.
- ❑ If the Magnify function is activated, press **enter** to cancel it.
- ❑ For a computer connection, turn everything off, then power on the projector first and power on the notebook or desktop computer second.
- ❑ For a computer connection, if the above steps do not correct the display image, adjust the resolution of the notebook or desktop computer to 1024 x 768.

If the image is flickering or unstable:

- Press the **auto sync** button on the projector panel or remote control.
- For a computer connection, set the display resolution to 1024 x 768.
- For a computer connection, open the on-screen menu and select **adjust picture > Advanced picture**. Try adjusting the **Frequency** or **Tracking**.

If the image is stretched:

- Open the on-screen menu and select **adjust picture > Aspect ratio**. Set to **Best fit**. For a wide-screen picture, try setting the aspect ratio to **16:9**. Try setting the aspect ratio to **1-to-1**.

If the image disappears from the computer screen:

- For a notebook computer, you might be able to turn on both the external VGA port and the built-in screen. See the computer manual or the projector's video port guide.
- For a desktop computer, you can connect your monitor to the projector's VGA output port.

If the projected colors seem slightly wrong:

- If the business graphics button on the projector is lit, try pressing the theatre video button on the projector or remote control.
- Open the on-screen menu and select **adjust picture > Advanced picture**. Adjust the advanced settings as needed.
- Open the on-screen menu and select **adjust picture > Color space**. Try changing the selection.
- Open the on-screen menu and select **help > Diagnostics**. Run color tests.

If the projected colors seem completely wrong:

- ❑ If the super-bright button on the projector is lit, the picture is displayed in grayscale. To display colors, press the business graphics button or the theatre video button on the projector or remote control.
- ❑ For a YPbPr or RGB input device, be sure all the video connectors are correctly matched.
- ❑ Ensure the pins on the cable connectors are not bent or broken.
- ❑ Open the on-screen menu and select **adjust picture > Color space**. Try changing the selection.
- ❑ Open the on-screen menu and select **help > Diagnostics**. Run color tests.
- ❑ Reset the picture settings to the factory-default settings. See the following problem.

If the picture settings are completely wrong and you cannot fix them:

- ❑ Reset the projection settings to the factory-default settings. To do this, hold down these three buttons on the projector for 5 seconds: **back + up-arrow + auto sync**. (This does not reset network settings.)

If a DVI device causes an error message or garbage on the screen:

- ❑ Certain high-definition digital sources incorporate HDCP (High-bandwidth Digital-Content Protection) content protection. Such content cannot be displayed by this projector. If the device has another output port, such as YPbPr, try connecting that port to the projector.

If a VGA monitor displays a bad picture for certain inputs:

- ❑ If you connect certain types of VGA monitors to the VGA output port, it might have a blank or erratic display for video inputs, but it should have a good display for computer graphics input. If this occurs, trying using a different type of monitor.

If the projector stops responding to all controls:

- ❑ If possible, turn off the projector. Then turn the main disconnect switch off, wait 60 seconds, then turn it on again.

Sound problems

If no sound is coming out of the projector:

- ❑ Be sure you have an audio cable securely connected between the projector and the input device.
- ❑ Be sure that the mute and volume settings are correct on the input device, such as a computer, DVD player, or camcorder.
- ❑ Open the on-screen menu and select **audio**. Check the following settings:
 - ◆ Mute is turned off.
 - ◆ Volume is correct.
 - ◆ Internal speakers are turned on.
 - ◆ Audio input select shows the correct audio input for your video port.

If the projector speakers interfere with an external audio system:

- ❑ Open the on-screen menu and select **audio > Internal speakers**. Then, disable the internal speakers.

Interruption problems

If the projector suddenly shuts down and the temperature light turns on:

- ❑ If the temperature light is blinking, the fan is not working. Allow the projector to cool for several minutes.
- ❑ If the temperature light is steady, the projector has overheated. Allow it to cool for several minutes.
- ❑ If airflow is obstructed, remove the obstruction.
- ❑ If possible, remove any sources of excess heat in the room.
- ❑ If the condition occurs after restarting the projector, contact HP to have the projector serviced or repaired.

If the lamp shuts off during a presentation:

- ❑ A minor power surge might cause the lamp to shut off. Wait a few minutes, then power on the projector.
- ❑ The lamp module might have burned out. Replace the lamp module.

If the lamp burns out or makes a popping sound:

- ❑ When the lamp reaches its end of life, it might burn out and make a popping sound. If this happens, the projector will not turn back on until the lamp module has been replaced.
- ❑ If the lamp breaks, contact HP about repairs that might be required.

Remote control problems

If the remote control does not operate:

- ❑ If the indicator light on the front of the remote control blinks when you press buttons, the remote control is working properly. If the light does not blink, install two new AAA batteries in the remote control.
- ❑ Be sure nothing is blocking the infrared receivers on the front and back of the projector. Move to within 9 m (30 ft) of the projector.
- ❑ Open the on-screen menu and select **help > Diagnostics**. Run remote control tests.

If only the mouse and page up and down buttons do not work:

- ❑ Be sure you have a USB connection between the projector and the computer.
- ❑ Open the on-screen menu and select **help > Diagnostics**. Run remote control.

Networking problems

If you cannot access the projector via the web:

- ❑ Check that you are using the correct IP address. The projector's IP address is shown in the on-screen menu on the projector.
- ❑ Check the network cable connections at the projector and at the wall.
- ❑ Check the left indicator light on the LAN port on the projector. If the light is not on, the network might not be active. Try a different cable or check the network outlet at the wall using a computer.
- ❑ If your model includes an L1581A Advanced Connectivity Module, see the L1581A manual.
- ❑ Check whether the projector's IP address shown in the on-screen menu is 169.254.x.x. If the projector is set to use a DHCP server, this address means no DHCP server is available. If the projector does not use a DHCP server, this address means no IP address is

set for the projector—contact the network administrator for a valid TCP/IP network configuration, then set up the projector accordingly.

If you forget the projector's web administrator password:

- ❑ Reset the projector's network configuration to the factory-default values. To do this, turn off the projector. Then insert a straightened paperclip into the small hole in the connectivity module panel. While pressing the small button inside, turn the main disconnect switch off and on and continue holding the button for at least 15 seconds.

If you can access the projector via the web, but only the home page:

- ❑ The web interface has been protected by the web administrator. Contact the administrator.

If the network configuration is completely wrong and you cannot fix it:

- ❑ Reset the projector's network configuration to the factory-default values. To do this, turn off the projector. Then insert a straightened paperclip into the small hole in the connectivity module panel. While pressing the small button inside, turn the main disconnect switch off and on and continue holding the button for at least 15 seconds.

Testing the Projector

The on-screen menu contains diagnostic tests you can use to verify the proper operation of the projector and the remote control.

To run the projector diagnostics

1. Open the on-screen menu and select **help > Diagnostics**.
2. Select a test to perform.



Discount-Merchant.com (800) 281-8860

THE TRUSTED SOURCE FOR PROJECTOR LAMPS AND ACCESSORIES

This chapter lists the specifications, safety information, and regulatory information for the projector. The chapter covers:

- “Specifications” on page 83.
- “Safety Information” on page 90.
- “Regulatory Information” on page 92.

Specifications

Because HP continually improves its products, the following specifications are subject to change. For the latest specifications, visit the HP website at <http://www.hp.com>.

Identifying the projector specifications

Luminance	<p>xp8010: Business graphics: 2200 ANSI lumens, 2600 ANSI (max) lumens Super bright: 3850 ANSI lumens, 4600 ANSI (max) lumens</p> <p>xp8020: Business graphics: 2350 ANSI lumens, 3000 ANSI (max) lumens Super bright: 3700 ANSI lumens, 4400 ANSI (max) lumens</p>
Resolution	XGA
Technology	DLP
Contrast ratio	800:1 (typical)

Identifying the projector specifications *(continued)*

Video connectors	M1-DA graphics (optional M1-DA cables for VGA, DVI, and SCART) VGA #1 input VGA #2 input VGA output S-video input Composite-video input (1 RCA) Component-video input (3 RCA) Analog BNC input (5 BNC)
Audio connectors	Appropriate video connectors paired with each video input Stereo audio output
I/O connectors	USB type-B for computer control Wired-remote control input 12-V output for motorized screen control
Connectivity module connectors	LAN (RJ45) RS-232 Advanced connectivity module only: two CompactFlash slots (Type II), two USB 1.1 Type A*, mini-phone microphone input* * Reserved for future use
IR receivers	Front and rear for remote control
Cable shroud	Included
Size	442 × 302 × 139 mm (17.4 × 11.9 × 5.5 in) including handle, focus ring, and feet
Weight	6 kg (14 lb)

Identifying the projector specifications (continued)

Lens	Standard: 1.98:1 to 2.38:1 throw ratio (distance/width) Accessories: Short-throw: 1.56:1 to 1.88:1 Long-throw: 2.35:1 to 2.81:1
Optical zoom	1.2:1
Digital zoom	Yes
Keystone	Up to $\pm 40^\circ$ vertical Up to $\pm 17^\circ$ horizontal
Audio	5-W peak stereo with sealed, resonating sound chambers
Lamp	xp8010: 250-W P-VIP lamp, 1.3-mm arc xp8020: 300-W P-VIP lamp, 1.3-mm arc 2000 hours rated life Lamp-saver mode reduces lamp power by 20% Replacement lamp: L1582A (xp8010), L1583A (xp8020)
Light engine	0.7 12° DDR DMD XGA
Color system	Dual color wheels providing three modes: Business graphics Theatre video Super-bright grayscale
Remote control	Integrated USB mouse with laser pointer Supports wired connection
Mounting options	Ceiling and tabletop, front and rear projection
Security	Kensington lock compatible
Power	100 to 120 V, 200 to 240 V at 50 to 60 Hz. Battery backup for time and date

Identifying the projector specifications (continued)

Noise level	xp8010: 32±2 dBA xp8020: 36±2 dBA
Environment	<p>Operating: Temperature: 10 to 35°C (50 to 95°F) Humidity: 80% RH max, non-condensing Altitude: up to 3,000 m (10,000 ft), up to 25°C (77°F)</p> <p>Storage: Temperature: -20 to 55°C (-4 to 131°F) Humidity: 80% RH max, non-condensing Altitude: up to 12,000 m (40,000 ft)</p>

Analog Video Mode Compatibility

Compatibility	Resolution	V-Sync (Hz)	H-Sync (kHz)
VGA	640 x 350	70	31.5
	640 x 350	85	37.9
	640 x 400	85	37.9
	640 x 480	60	31.5
	640 x 480	72	37.9
	640 x 480	75	37.5
	640 x 480	85	43.3
	720 x 400	70	31.5
	720 x 400	85	37.9
SVGA	800 x 600	56	35.2
	800 x 600	60	37.9
	800 x 600	72	48.1
	800 x 600	75	46.9

Analog Video Mode Compatibility

Compatibility	Resolution	V-Sync (Hz)	H-Sync (kHz)
	800 x 600	85	53.7
XGA	1024 x 768	60	48.4
	1024 x 768	70	56.5
	1024 x 768	75	60.0
	1024 x 768	85	68.7
SXGA	1280 x 1024	60	63.98
	1280 x 1024	75	79.98
SXGA+	1400 x 1050	60	63.98
UXGA	1600 x 1200	60	75
UXGA	1600 x 1200	75	93.75
MAC LC 13	640 x 480	66.66	34.98
MAC II 13	640 x 480	66.68	35
MAC 16	832 x 624	74.55	49.725
MAC 19	1024 x 768	75	60.24
MAC	1152 x 870	75.06	68.68
MAC G4	640 x 480	60	31.35
MAC G4	640 x 480	120	68.03
MAC G4	1024 x 768	120	97.09
i Mac DV	640 x 480	117	60
i Mac DV	800 x 600	95	60
i Mac DV	1024 x 768	75	60
i Mac DV	1152 x 870	75	68.49

Analog Video Mode Compatibility

Compatibility	Resolution	V-Sync (Hz)	H-Sync (kHz)
i Mac DV	1280 x 960	75	75
i Mac DV	1280 x 1024	75	90.9

Digital Video Mode Compatibility

Compatibility	Resolution	V-Sync [Hz]	H-Sync [kHz]
VGA	640 x 350	70	31.5
	640 x 350	85	37.9
	640 x 400	85	37.9
	640 x 480	60	31.5
	640 x 480	72	37.9
	640 x 480	75	37.5
	640 x 480	85	43.3
	720 x 400	70	31.5
	720 x 400	85	37.9
SVGA	800 x 600	56	35.2
	800 x 600	60	37.9
	800 x 600	72	48.1
	800 x 600	75	46.9
	800 x 600	85	53.7
XGA	1024 x 768	60	48.4
	1024 x 768	70	56.5
	1024 x 768	75	60.0
SXGA	1280 x 1024	60	63.98

Digital Video Mode Compatibility

Compatibility	Resolution	V-Sync [Hz]	H-Sync [kHz]
	1280 x 1024	75	79.98
SXGA+	1400 x 1050	60	63.98
UXGA	1600 x 1200	60	75

Safety Information

Safety precautions

- To prevent eye injury, do not look into the lens when the lamp is on. Do not point any laser light at anyone's eyes.
- To prevent electrical shock, do not expose the projector to rain or moisture. Do not open the projector except as instructed by the manual.
- Allow the projector to cool before removing any cover and touching internal components, as instructed by the manual.
- Keep paper and other combustible material away from the projector lens to prevent the possibility of fire.
- Use only an approved power cord rated for the voltage and current marked on the product label. Do not overload any outlet or extension cord.

Laser safety

The laser pointer on the remote control is certified as Class 2 laser device according to the U.S. Department of Health and Human Services (DHHS) Radiation Performance Standard and International Standards IEC 825/IEC 825-1 (EN60825/EN60825-1). This device is not considered harmful, but the following precautions are recommended:

- Ensure proper use by reading and following the instructions carefully.
- If the unit requires service, contact an authorized HP service center.
- Do not attempt to make any adjustment to the unit.
- Avoid direct exposure to the laser beam.

LED safety

The infrared ports located on the digital projector and remote control are classified as Class 1 LED devices according to International Standard IEC 825-1 (EN60825-1). This device is not considered harmful, but the following precautions are recommended:

- If the unit requires service, contact an authorized HP service center.
- Do not attempt to make any adjustment to the unit.
- Avoid direct eye exposure to the infrared LED beam. Be aware that the beam is invisible light and cannot be seen.
- Do not attempt to view the infrared LED beam with any type of optical device.

Mercury safety



WARNING: This digital projector lamp contains a small amount of mercury. If the lamp breaks, adequately ventilate the area where the breakage occurred. Disposal of the lamp might be regulated due to environmental considerations. For disposal or recycling information, please contact your local authorities or the Electronic Industries Alliance <http://www.eiae.org>.

Regulatory Information

This section presents information that shows how your digital projector complies with regulations in certain regions. Any modifications to your digital projector not expressly approved by HP could void the authority to operate the digital projector in these regions.

U.S.A.

This digital projector has been tested and found to comply with the limits for a Class B digital device, pursuant to Part 15 of the FCC Rules. These limits are designed to provide reasonable protection against harmful interference in a residential installation.

This digital projector generates, uses, and can radiate radio frequency energy. If not installed and used in accordance with the instructions, it can cause harmful interference to radio communications. However, there is no guarantee that interference will not occur in a particular installation. If this digital projector does cause harmful interference to radio or television reception (which can be determined by unplugging the unit), try the following:

- Reorienting or relocating the receiving antenna.
- Relocating the digital projector with respect to the receiver.
- Connecting the digital projector's power cord to another power outlet.

Connections to peripheral devices

To maintain compliance with FCC Rules and Regulations, use properly shielded cables with this device.

For more information, consult your dealer, an experienced radio/television technician, or the following booklet, prepared by the Federal Communications Commission, *How to Identify and Resolve Radio-TV Interference Problems*. This booklet is available from the U.S. Government Printing Office, Washington, DC 20402, Stock Number 004-000-00345-4. At the first printing of this manual, the telephone number was (202) 512-1800.

Canada

This Class B digital apparatus complies with Canadian ICES-003.

Japan

この装置は、情報処理装置等電波障害自主規制協議会（VCCI）の基準に基づくクラスB情報技術装置です。この装置は、家庭環境で使用することを目的としていますが、この装置がラジオやテレビジョン受信機に近接して使用されると受信障害を引き起こすことがあります。

取り扱い説明書に従って正しい取り扱いをして下さい。

Korea

사용자 안내문 : **B** 급 기기

이 기기는 비업무용으로 전자파적합등록을 받은 기기이오니, 주거지역에서는 물론, 모든 지역에서 사용 하실 수 있습니다.

International

For regulatory identification purposes, your product is assigned a regulatory model number. The regulatory model number for your product is listed in the declaration following table. This regulatory number is different from the marketing name and product number.

DECLARATION OF CONFORMITY

According to ISO/IEC Guide 22 and EN 45014

Manufacturer's Name: Hewlett Packard Company
Manufacturer's Address: Hewlett Packard Company
Digital Projection & Imaging
1000 NE Circle Blvd.
Corvallis, OR 97330-4239

Declares, that the product(s):

Product Name: Digital Projector
Model Number(s): xp8010 and xp8020
Regulatory Model: CRVSB-03CA and CRVSB-04CA

Conforms to the following product specifications:

Safety: IEC 60950:1999/ EN 60950:2000
IEC 60825-1:1993 +A1 / EN 60825-1:1994 +A11 Class 1 LED
GB4943-1995

EMC: EN 55022: 1998 Class B [1]
CISPR 24:1997 / EN 55024: 1998
IEC 61000-3-2:1995 / EN 61000-3-2:2000
IEC 61000-3-3:1994 / EN 61000-3-3:1995+A1:2001
GB9254-1998
FCC Title 47 CFR, Part 15 Class B/ANSI C63.4:1992
AS/NZS CISPR 22:2002

Supplementary information:

The product herewith complies with the requirements of following Directives and carries the CE marking accordingly:

-Low Voltage Directive: 73/23/EEC
-EMC Directive: 89/336/EEC

[1] The product was tested in a typical configuration with Hewlett Packard Personal Computer peripherals. This device complies with Part 15 of the FCC Rules. Operation is subject to the following two conditions: (1) this device may not cause harmful interference, and (2) this device must accept any interference received, including interference that may cause undesired operation.
Corvallis, Oregon, March 1, 2004



Steve Brown, General Manager

European Contact for regulatory topics only: Hewlett Packard GmbH, HQ-TRE, Herrenberger Straße 140, 71034 Boeblingen, Germany. (FAX:+49-7031-143143).

USA Contact: Hewlett Packard Co., Corporate Product Regulations Manager, 3000 Hanover Street, Palo Alto, CA 94304. Phone: (650) 857-1501.



Discount-Merchant.com (800) 281-8860

THE TRUSTED SOURCE FOR PROJECTOR LAMPS AND ACCESSORIES

Index

A

- accessories
 - listing 16
 - see Reference Guide*
- add-on lens
 - installing 57
 - range 57
- adjustments
 - from the web 41
- admin. account
 - see configuration*
- aiming the projector
 - raising and lowering 38
- alerts
 - see email*
- analog video mode
 - compatibility 86
- audio
 - adjusting 39
 - connecting 27, 43

B

- back panel
 - identifying 12
- business graphics mode
 - see picture mode*
- buttons
 - projector 11
 - remote control 14

C

- ceiling installation
 - setting up 18
- ceiling mount 19
- ceiling mount bracket
 - see ceiling installation*
- computer
 - connecting 27, 43
- configuration
 - admin. account 55
 - protecting 55
 - using on-screen menu 34
- connecting computer
 - with M1 to DVI 28, 47
 - with M1 to VGA 27, 28, 44, 46
- connecting devices 43
 - see Reference Guide*
- connecting DVD
 - see also connecting input sources*
 - with YPbPr ports 48
- connecting input sources
 - computer with M1 cable to DVI 28, 47
 - computer with M1 cable to VGA 28, 46
 - computer with VGA cable 27, 44
 - DVD or HDTV with triple RCA cable 30
 - RGA equipment 31
 - RGBC equipment 31
 - RGBHV equipment 32
 - SCART device 30
 - VCR with video cable 29, 48

connecting output devices
 monitor and speaker 32

connections
 see back panel

connectivity module
 installing 59
 removing 59

contents
 in the box 8

D

digital video mode
 compatibility 88

disconnecting
 projector 51

distance
 see also lens
 setting up with respect to image 17

E

email
 setting notifications 55

embedded web server 53

events
 see email

F

firmware
 updating from network 56
 updating from serial port 56

focus
 adjusting 39
 range of 39

G

graphics mode
 see picture mode

H

handheld organizer
 connecting 45
hide button 50

I

input/output connectors
 see back panel

installation
 see Reference Guide

installing
 see location

IP address
 finding 53
 setting 35

K

Kensington lock 36

L

lamp module
 replacing 69
 see Reference Guide

laser pointer 25

laser safety
 precautions 90

LED safety
 precautions 91

lens
 cleaning 68
 damaging 68
 finding range 57
 installing 57

lights
 identifying 11

location
 see also ceiling installation
 see also rear projection installation
 see also table installation
 selecting 17

lock 36

see Reference Guide

lower-mount bracket

see ceiling installation

M

maintenance

routine maintenance 68

see Reference Guide

menu

see on-screen menu

mercury 70

N

network

advanced 54

configuring 54

connecting 35

troubleshooting 35

network access

connecting 35

networking

see Reference Guide

notifications

see email

O

on-screen menu

adjust picture menu definitions 64

audio menu definitions 66

help menu definitions 67

input menu definitions 62

quick choice menu definitions 62

setup menu definitions 66

using 34

P

password

disabling 55

setting 55

picture

adjusting 40

picture mode

changing 26, 40

definition 40

power

plugging in 23

turning off 25

turning on 24

presentations

from a computer 49

source changing 50

projector

identifying parts 10

maintaining 68

maintaining *see Reference Guide*

R

rear panel

see back panel

rear projection installation

setting up 21

regulatory information

Canada 92

European Union 94

Japan 93

Korea 93

U.S.A. 92

remote control

battery replacement 70

extension 33

identifying with doors closed 14

identifying with doors open 15

using 25

remote control extension 33

resetting

network settings 80

projection settings 76

projector 26

S

- safety information
 - laser safety 90
 - LED 91
 - precautions 90
- securing the projector
 - installing lock 36
- security
 - locking 36
 - see Reference Guide*
- SMTP
 - see email*
- sound
 - see audio*
- source
 - changing 50
 - connecting 27, 43
- specifications
 - of the projector 83
 - see Reference Guide*
- status
 - on-screen menu viewing 68
 - web viewing 54
- super-bright mode
 - see picture mode*

T

- table installation
 - setting up 18
- TCP/IP
 - see network*
- testing
 - diagnostics 81

- theatre video mode
 - see picture mode*
- troubleshooting
 - interruption problems 78
 - picture problems 73
 - remote control problems 79
 - sound problems 77
 - start-up problems 72
 - suggestions 71
- turning off 25
 - disconnecting 51
- turning on 24

U

- upgrading
 - see add-on lens installing*
 - see firmware updating*
- using 50

V

- video
 - connecting 27, 43
- video mode
 - see picture mode*

W

- web
 - accessing projector 41, 54

Z

- zoom
 - adjusting 39
 - range of 39



Disclaimer

This user manual is provided as a free service by FixYourDLP.com. FixYourDLP is in no way responsible for the content of this manual, nor do we guarantee its accuracy. FixYourDLP does not make any claim of copyright and all copyrights remain the property of their respective owners.

About FixYourDLP.com

FixYourDLP.com (<http://www.fixyourdpl.com>) is the World's #1 resource for media product news, reviews, do-it-yourself guides, and manuals.

Informational Blog: <http://www.fixyourdpl.com>

Video Guides: <http://www.fixyourdpl.com/guides>

User Forums: <http://www.fixyourdpl.com/forum>

FixYourDLP's Fight Against Counterfeit Lamps:

<http://www.fixyourdpl.com/counterfeits>

Sponsors:

RecycleYourLamp.org – Free lamp recycling services for used lamps:

<http://www.recycleyourlamp.org>

Lamp Research - The trusted 3rd party lamp research company:

<http://www.lampresearch.com>

Discount-Merchant.com – The worlds largest lamp distributor:

<http://www.discount-merchant.com>



FixYourDLP.com

Sponsored by 