



Disclaimer

This user manual is provided as a free service by FixYourDLP.com. FixYourDLP is in no way responsible for the content of this manual, nor do we guarantee its accuracy. FixYourDLP does not make any claim of copyright and all copyrights remain the property of their respective owners.

About FixYourDLP.com

FixYourDLP.com (<http://www.fixyourdlp.com>) is the World's #1 resource for media product news, reviews, do-it-yourself guides, and manuals.

Informational Blog: <http://www.fixyourdlp.com>

Video Guides: <http://www.fixyourdlp.com/guides>

User Forums: <http://www.fixyourdlp.com/forum>

FixYourDLP's Fight Against Counterfeit Lamps:

<http://www.fixyourdlp.com/counterfeits>

Sponsors:

RecycleYourLamp.org – Free lamp recycling services for used lamps:

<http://www.recycleyourlamp.org>

Lamp Research - The trusted 3rd party lamp research company:

<http://www.lampresearch.com>

Discount-Merchant.com – The worlds largest lamp distributor:

<http://www.discount-merchant.com>



FixYourDLP.com

Sponsored by 

ViewSonic®

PJ250

User Guide

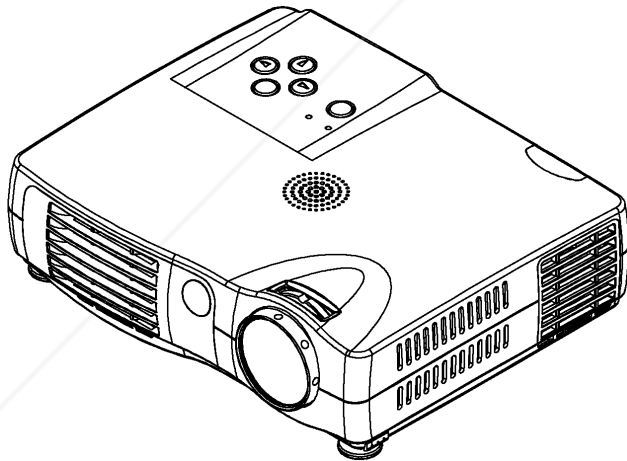

 **FixYourDLP.com**
Sponsored by 

Discount-Merchant.com (800) 281-8860
THE TRUSTED SOURCE FOR PROJECTOR LAMPS AND ACCESSORIES

Contents

For Your Records	1
Accessories Included	2
Projector Components	3
Remote Control Components	4
Connections with the Personal Computer.....	5
Connections with Video Equipment	6
Operating the Projector.....	7
Turning the projector Off	8
Using the Quick Menu.....	9
Menu Operation	10
STATUS Indicator Light	13
Replacing the Lamp Cartridge	14
Specifications.....	16
Distance Chart	17
Cabinet Dimensions.....	18
Customer Support.....	19
WARRANTY	20
Appendix.....	21
Power Cord Safety Guidelines.....	21
IMPORTANT SAFETY INFORMATION.....	22
Important Safeguards	22
Compliance Information for U.S.A.	23
Compliance Information for Canada	23
Compliance Information for European Countries.....	23
User Information for all Countries	23



Discount-Merchant.com (800) 281-8860
THE TRUSTED SOURCE FOR PROJECTOR LAMPS AND ACCESSORIES

Copyright © ViewSonic Corporation, 2002. All rights reserved.

Apple, Mac and ADB registered trademarks of Apple Computer, Inc.

Microsoft, Windows, Windows NT, and the Windows logo are registered trademarks of Microsoft Corporation in the United States and other countries.

ViewSonic, the three birds logo and OnView are registered trademarks of ViewSonic Corporation.

VESA and SVGA are registered trademarks of the Video Electronics Standards Association.

DPMS and DDC are trademarks of VESA.

PS/2, VGA and XGA are registered trademarks of International Business Machines Corporation.

ViewSonic Corporation has determined that this product meets the ENERGY STAR® guidelines for energy efficiency.

Disclaimer: ViewSonic Corporation shall not be liable for technical or editorial errors or omissions contained herein; nor for incidental or consequential damages resulting from furnishing this material, or the performance or use of this product.

In the interest of continuing product improvement, ViewSonic Corporation reserves the right to change product specifications without notice. Information in this document may change without notice.

No part of this document may be copied, reproduced, or transmitted by any means, for any purpose without prior written permission from ViewSonic Corporation.

Electronic Warranty Registration

To meet your future needs, and to receive any additional product information as it becomes available, please register your projector's warranty on the Internet at: <http://www.viewsonic.com>

For Your Records

Product Name:	PJ250
Model Number:	VPROJ26264-1W
Document Number:	
Serial Number:	B16 _____
Purchase Date:	_____



Discount-Merchant.com (800) 281-8860
THE TRUSTED SOURCE FOR PROJECTOR LAMPS AND ACCESSORIES

Accessories Included

Remove the main unit and the accessories from the box and check that the following items are included.

- Quick Start Guide
- ViewSonic wizard CD
- Lens cap (affixed to the projector)
- Remote control (includes one button battery)
- Power cable (1.8 m / 5.9 ft)
- DVI / Mini D-sub 15-pin conversion cable (19 cm / 7.5 in)
- RGB signal cable (Mini D-sub 15-pin, 2 m / 6.6 ft)
- S-Video cable (3.5 mm diameter plug / Mini DIN 4-pin plug, 1.5 m / 4.9 ft)
- Video cable (3.5 mm diameter plug / RCA pin plug, 1.5 m / 4.9 ft)
- Audio cable (2.5 mm diameter plug / RCA pin plug, 1.5 m / 4.9 ft)
- Soft carry case

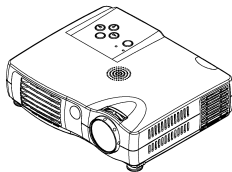

Projector

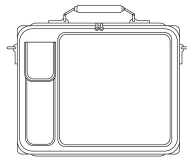

Carrying case



Quick Start Guide



ViewSonic Wizard CD

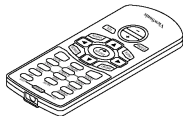

Remote control
(includes one button battery)



Power cable
(1.8 m / 5.9 feet)

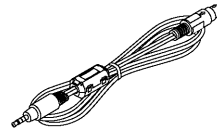

S-Video cable (3.5 mm diameter plug / Mini DIN 4-pin plug, 1.5 m / 4.9 feet)

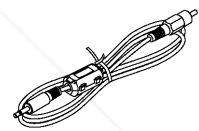

Video cable (3.5 mm diameter plug / RCA pin plug, 1.5 m / 4.9 feet)

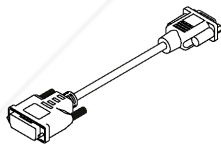

DVI / Mini D-sub 15-pin conversion cable
(19 cm / 7.5 feet)

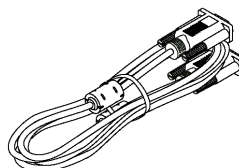

RGB signal cable
(Mini D-sub 15-pin, 2 m / 6.6 feet)

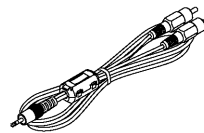

Audio cable (2.5 mm diameter plug / RCA pin plug, 1.5 m / 4.9 feet)



Discount-Merchant.com (800) 281-8860
THE TRUSTED SOURCE FOR PROJECTOR LAMPS AND ACCESSORIES

Projector Components

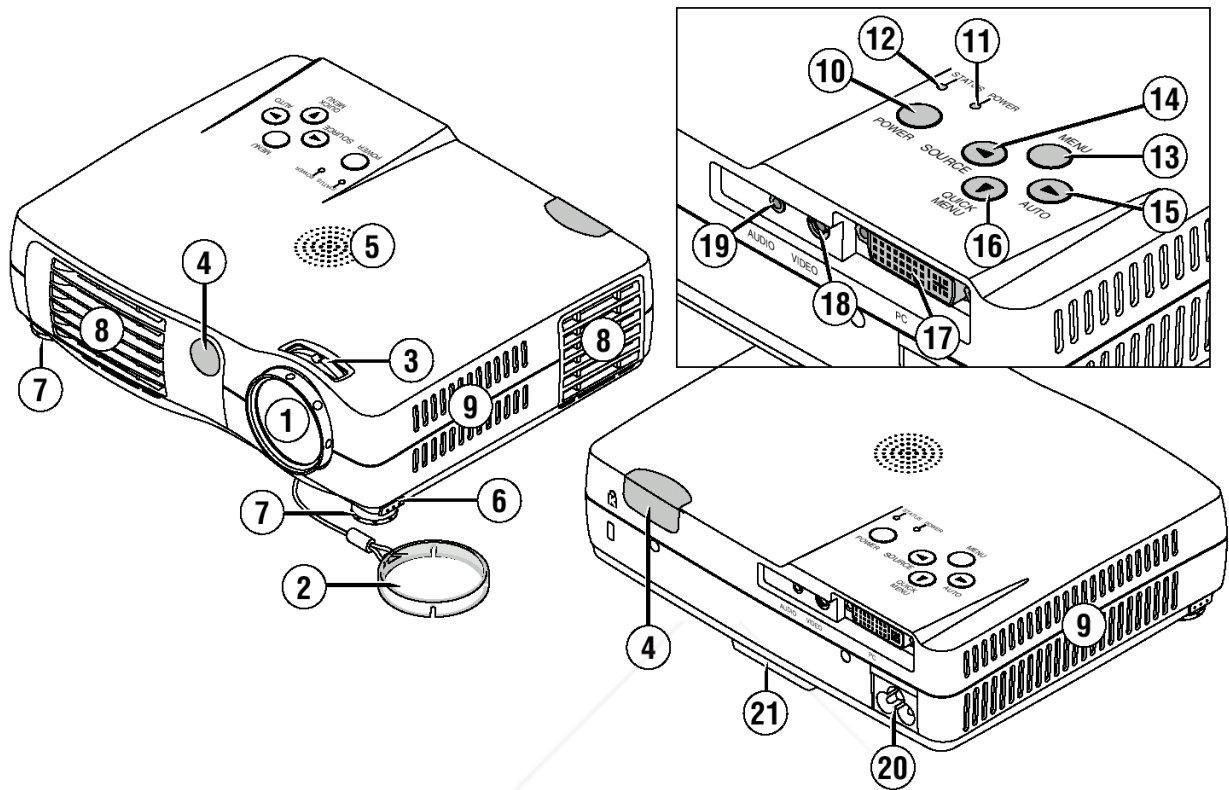

- | | |
|--------------------------------------------------------------------------------------------------------------------------------------------------------------------------------------------------------------------------------------------------------------------------------------------------------------------------------------------------------------------------------|-----------------------------------------------------------------------------------------------------------------------------------------------------------------------------------------------------------------------------------------------------------------------------------------------------------------------------------------------------|
| <ul style="list-style-type: none"> 1. Lens 2. Lens cap 3. Focus ring 4. Remote control sensor 5. Speaker 6. Front Adjustment button 7. Front Adjustment Foot 8. Exhaust vents 9. Ventilation slots 10. POWER button 11. POWER indicator 12. STATUS indicator | <ul style="list-style-type: none"> 13. MENU button 14. SOURCE button / Cursor ◀ button 15. AUTO button / Cursor ▶ button 16. QUICK MENU button / Cursor ▼ button 17. PC connector 18. VIDEO jack 19. AUDIO jack 20. AC IN connector 21. Rear Adjustment Foot |
|--------------------------------------------------------------------------------------------------------------------------------------------------------------------------------------------------------------------------------------------------------------------------------------------------------------------------------------------------------------------------------|-----------------------------------------------------------------------------------------------------------------------------------------------------------------------------------------------------------------------------------------------------------------------------------------------------------------------------------------------------|

Remote Control Components

Before use, pull out and remove the transportation insulation sheet which is inserted in the battery compartment.

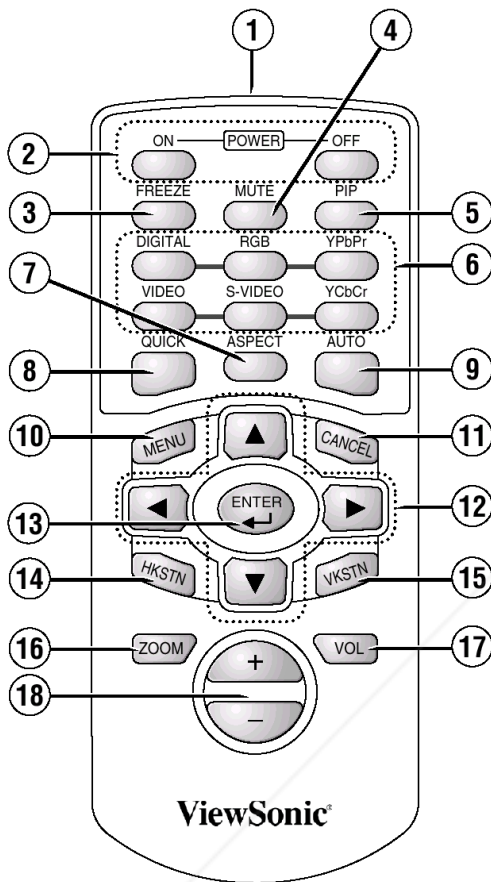
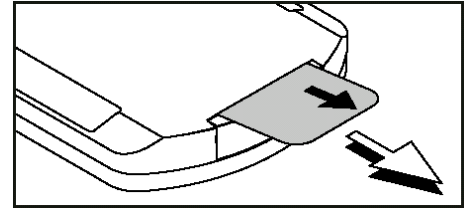

1. Infrared transmitter
2. POWER ON and OFF buttons
3. FREEZE button
4. MUTE button
5. PIP button
6. Input selection Buttons
7. ASPECT button
8. QUICK button
9. AUTO button
10. MENU button
11. CANCEL button
12. Cursor Buttons
13. ENTER button
14. HKSTN button
15. VKSTN button
16. ZOOM button
17. VOL button
18. +/- Buttons

CAUTION

- Danger of explosion if battery is incorrectly replaced.
Replace only with the same or equivalent type (CR2025) recommended by the manufacturer.
Dispose of used batteries according to your local regulations.

Precautions

Handling of the Remote Control

- Do not expose the remote control to water or other liquids. Should the remote control become wet, wipe it dry immediately.
- Please keep button batteries out of the reach of children. If a battery is swallowed, promptly obtain the medical care of a doctor.
- Some operations are available only through the use of the remote control and attention should be given to its careful handling.

Connections with the Personal Computer

- The projector's native resolution is 1024 X 768 pixels XGA,scalable to 1280 X 1024 pixels SXGA.
Note that input of a resolution that exceeds the displayable resolution will cease to be projected and should this be the case, you will need to change the resolution to a displayable resolution on the computer.
- The setting method of the personal computer will differ depending on the personal computer that you are using. For more information, read the instruction manual for your personal computer, or contact the manufacturer of your personal computer.

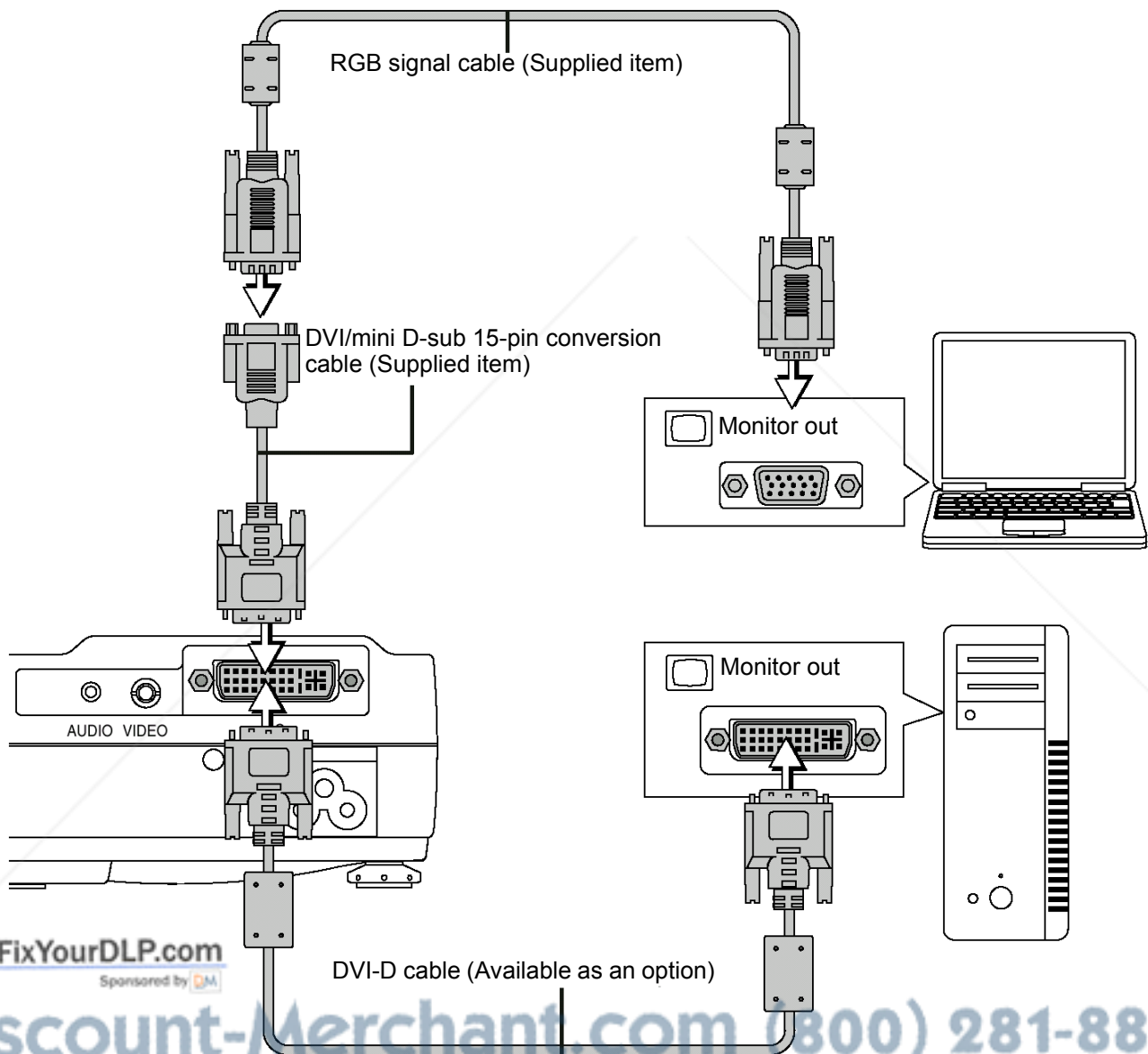

FixYourDLP.com
Sponsored by DM

Discount-Merchant.com (800) 281-8860

THE TRUSTED SOURCE FOR PROJECTOR LAMPS AND ACCESSORIES

Connections with Video Equipment

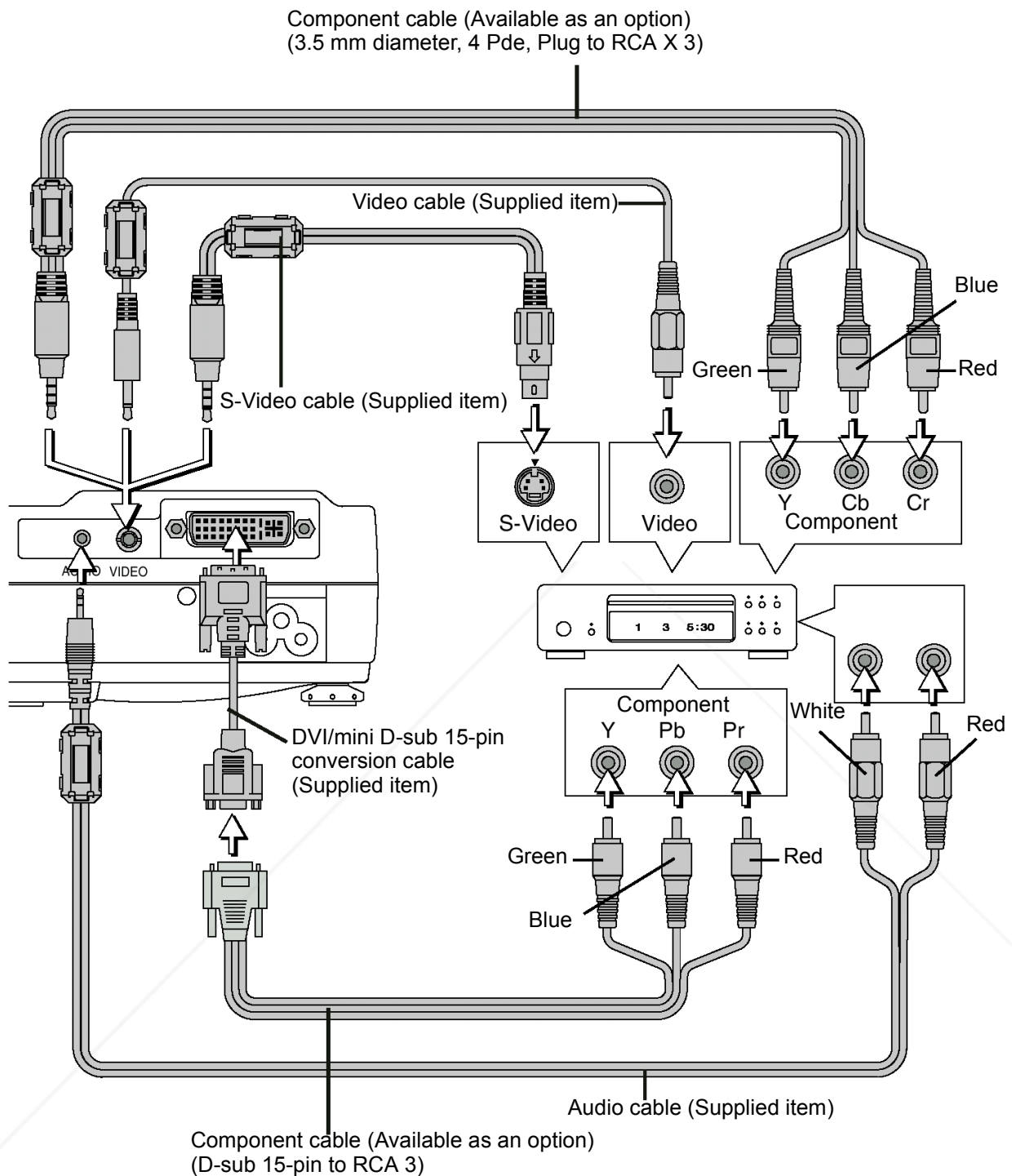

FixYourDLP.com
Sponsored by DM

Note:

- This projector's video cable and S-video cable are unique cables. To purchase extension cables, please contact your dealer.
- The AUDIO jack of the projector is a 2.5 mm diameter stereo mini jack. Connection is not possible using the common (3.5 mm diameter) stereo mini jack cable from the headphone jack of the personal computer or video equipment.

Operating the Projector

- 1 Set up the screen and the projector
See the affixed "Projection Distance Table" for the desired distance between the screen and the projector.
- 2 Connect the personal computer or video equipment to the projector.
- 3 Connect the AC IN connector of the projector and the power outlet using the supplied power cable.
The POWER indicator will light amber, the cooling fan will rotate at low speed, and the unit will enter the standby mode.

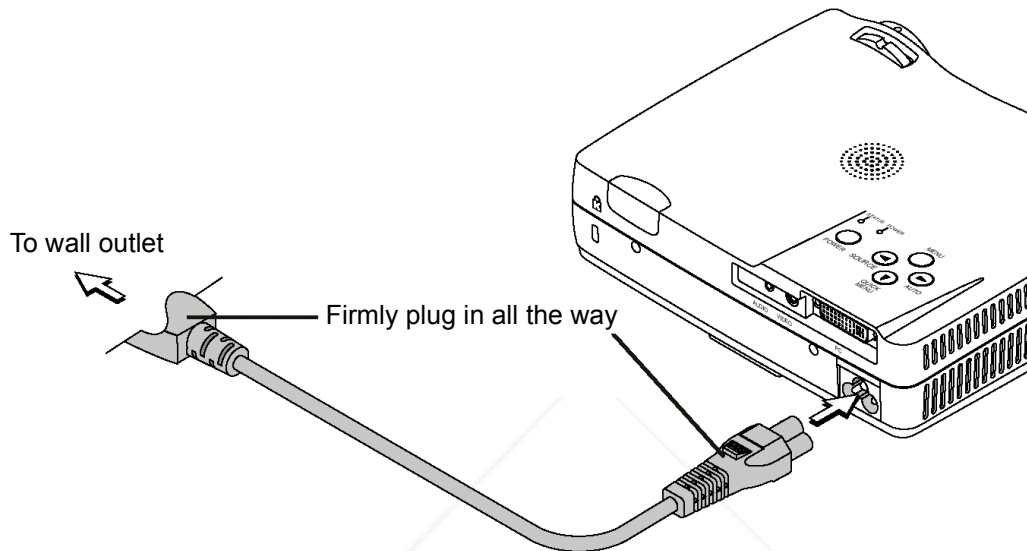

- 4 Switch the projector power on.
Main unit operation: Press and hold the POWER button for several seconds.
Remote control operation: Press the POWER ON button.

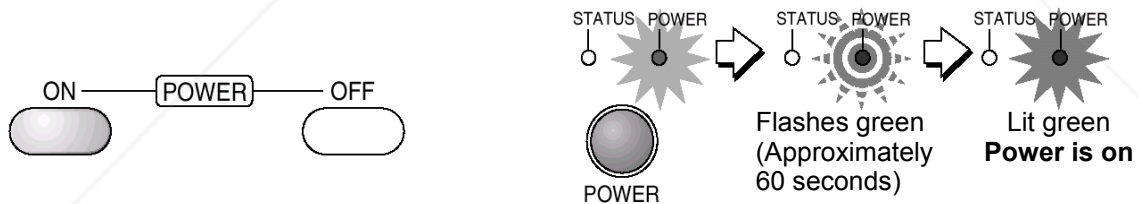

The POWER indicator changes to a flashing green and lights steadily after about 60 seconds. The projection screen brightens after about 40 seconds. The projector is now capable of regular projection.

- 5 Switch the power of the connected equipment on.
- 6 Select the input
Main unit operation: Press the SOURCE button.
Remote control operation: Press the desired button from among the input selection buttons.

FixYourDLP.com
DiscountMerchant.com (800) 281-8860
THE TRUSTED SOURCE FOR PROJECTOR LAMPS AND ACCESSORIES

Turning the projector Off

1 Switch the power button off.

Main unit operation: Press and hold the POWER button for several seconds.

Remote control operation: Press the POWER OFF button.

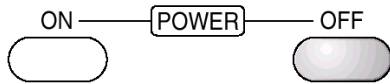

The "Power off" indication will appear.

When the red bar extends fully (approximately 5 seconds), the projection screen will turn off and the unit will enter the power off operation.

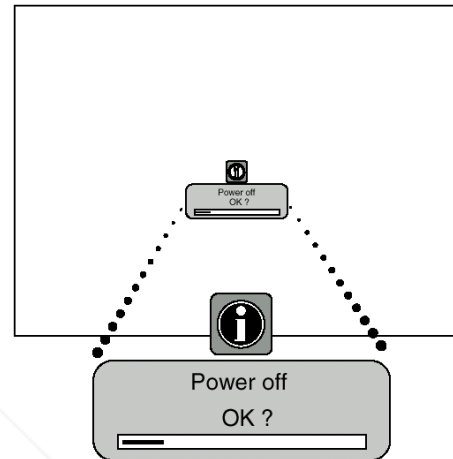

Note

- The operation can be cancelled by pressing a button other than the POWER button.
- One more press of the POWER (POWER Off) button will switch off the power.

When the unit enters the standby mode the POWER indicator changes from a flashing amber and lights a steady amber after about 90 seconds.

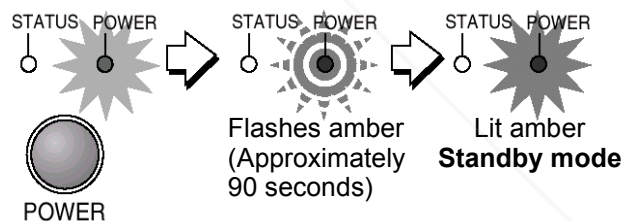

2 Unplug the power cable.

Check that the POWER indicator is lit amber and then unplug the power cable.

The POWER indicator will go off when the power cable is unplugged.

WARNING:

Do not unplug the power cable while the POWER indicator is flashing amber. Doing so may shorten the life of the lamp or damage the projector.



Discount-Merchant.com

Sponsored by DM

Discount-Merchant.com (800) 281-8860

THE TRUSTED SOURCE FOR PROJECTOR LAMPS AND ACCESSORIES

Using the Quick Menu

Note that the Quick Menu will not be displayed unless the signal of the connected equipment is detected. Please select the input that you wish to adjust.

Main unit operation

- (1) Press the QUICK MENU button to access the Quick Menu.
Press again to select the desired adjustment display.
- (2) Press the ◀ or ▶ button to adjust.
- (3) To close the display immediately, press the MENU button.
In the absence of operations for a period of about 10 seconds, the display will close automatically.

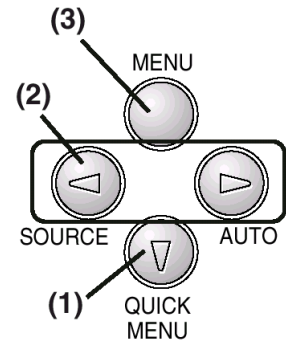

Remote control operation

- (1) Press the QUICK MENU button to access the Quick Menu. Further presses cause the adjustment display to change in sequence.
The adjustment display can be selected with use of either the cursor ▲ or ▼ button.
- (2) Press the cursor ◀ or ▶ button to make the adjustment.
- (3) To close the display immediately, press the CANCEL button.
In the absence of operations, the display will close automatically in a period of about 10 seconds.

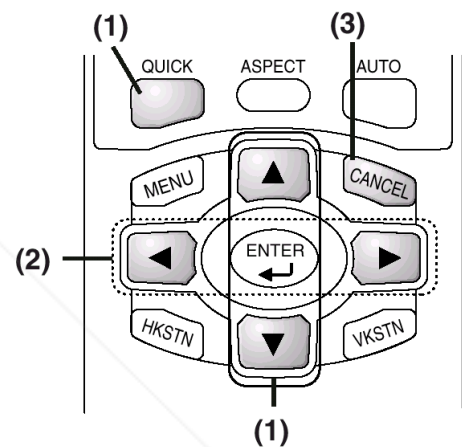

Content of Adjustments and Settings

Example: Brightness adjustment display

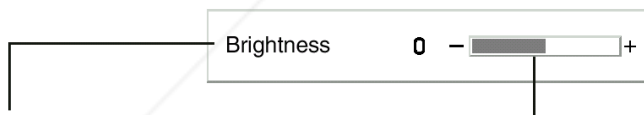

Display Item	Adjustment/Setting
Brightness	Adjusts the brightness of the image.
Contrast	Adjusts the contrast of the image.
V Keystone	Corrects (vertical) keystone distortion of the screen. Adjusts the left and right edges of the screen so that they are parallel.
H Keystone	Corrects (horizontal) keystone distortion of the screen. Adjusts the upper and lower edges of the screen so that they are parallel.
Picture in Picture	The picture from the VIDEO jack is displayed as a sub-picture on the input screen from the PC connector. This function selects either the size of the sub-picture (i.e. large, medium, or small) or off (i.e. no display). (Neither the adjustment display nor the picture will be output unless the signal is input to the PC connector.)
Volume	This function adjusts the volume of the built-in speaker.

Menu Operation

Remote Control

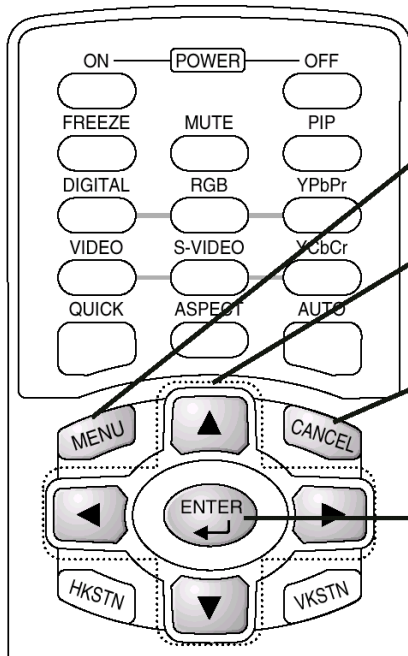

MENU button

Used for menu display and menu closure.

CURSOR(▲▼◀▶) button

Selects menu names and item names as well as in setting and adjusting the item contents.

CANCEL button

Returns to menu name selection as well as to close the menu (and the sub menu display).

ENTER button

Sets the verification display.

Projector

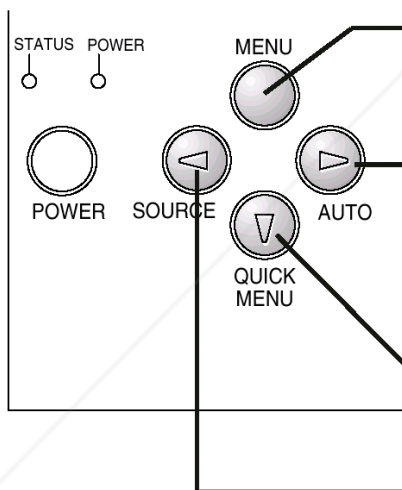

MENU button

Displays menu, to return to menu name selections, and to close menus (i.e. closing sub menu displays).

▶ (AUTO) button

Advances the selection of menu names. Advances the setting/adjustment values of the item contents. Also serves the function of the remote control ENTER button.

▼ (QUICK MENU) button

Selects of item names.

◀ (SOURCE) button

Returns to the selection of menu names. Advances the setting/adjustment values of the item contents.

On Screen Display

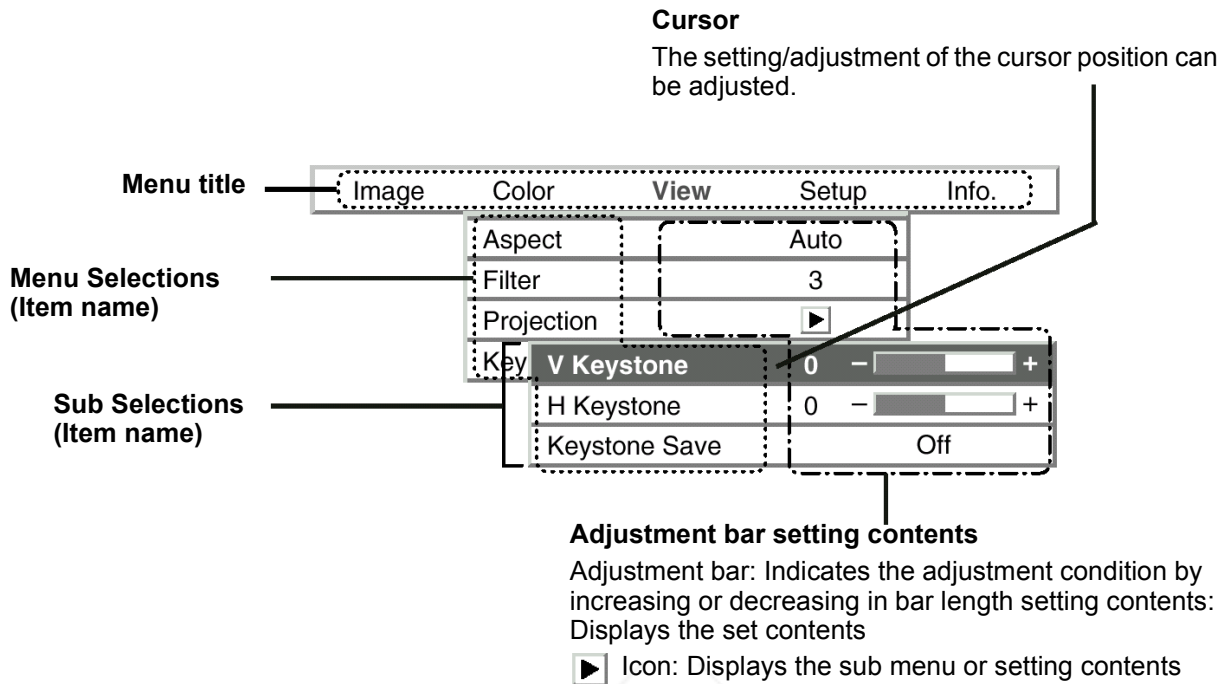

- The remote control should be pointed toward the remote control sensor of the projector and operated.
- When no signal is detected, only "Color", "Setup", and "Info." can be selected. ("Color" can be selected for Video and S-Video source only.)
- The menu will close automatically if no buttons are pushed within 30 seconds.

Menu Display

- 1 Press the MENU button to display the menu

Note : Pressing the main unit MENU button will change the function of the SOURCE button, AUTO button, and QUICK MENU button to that of cursor buttons.

Menu Selection

2 Press the cursor (◀▶) button to select the menu item you wish to adjust.

Each press of the cursor (▶) button advances the selection one step in the sequence of "Color" → "View" → "Setup" → "Info." → "Image".

Each press of the cursor (◀) button causes a return of one step.

The selected menu name will appear in red.

Note : To cancel the display of the cursor, press the CANCEL button on the remote control or the MENU button on the projector.

Displaying the Cursor

3 Press the cursor (▼) button to display the cursor .

Image	Color	View	Setup	Info.
	Aspect		Auto	
	Filter		3	
	Projection		▶	
	Keystone		▶	

Selection of the Item Name

4 Press the cursor (▲▼) button to align the cursor with the item name.

Main unit operation: Press the ▾ (QUICK MENU) button. When the cursor has moved to the very bottom of the items, another press will move it to the very top of the items.

When the ▶ icon is displayed and depending on the item contents, a press of the cursor (▶) button will result in the sub menu, the setting display, a resetting of the adjustment value, or a resetting verification display.

Making Adjustments/Settings

5 Press the cursor (◀▶) button and make the adjustment (or setting) while viewing the image. When a button is pressed, the image will also change.

Closing the Menu

6 Press the MENU button and close the menu display.

Main unit operation: Press the MENU button and delete the cursor. The operation will differ depending on the display contents when a sub menu is displayed. Should a sub menu be displayed, press the MENU button until the MENU display closes.

STATUS Indicator Light

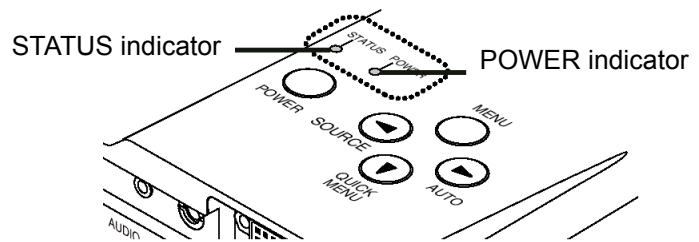

STATUS Indicator	POWER Indicator	Problem
Flashes red (0.5 s lit / 0.5 s off)	Lit red	The temperature has become abnormally high. The thermal protector is activated. If the room temperature is high, move the projector to a cool location. If the internal temperature of the projector is high, check the ventilation holes of the cooling fan and clean them if they are obstructed. When the thermal protector is activated, the power is switched off and even if the power is soon switched back on, the power might not actually be supplied to the projector. Should this happen, wait one minute and then switch the power on again.
Flashes red (1 s lit / 1 s off)	When the lamp burns out during operation: Flashes amber for 90 seconds and then stays lit When the lamp does not turn on: Lit amber	The lamp will not turn on Wait one minute or longer while the lamp lighting voltage irregularity detection protector is activated and switch the power on again. If the problem still persists, unplug the power cable and contact ViewSonic.
Flashes red (0.5 s lit / 0.5 s off)	Lit amber	The fan has stopped. Unplug the power cable and contact ViewSonic.
Flashes red (1 s lit / 1 s off)	Lit red	The lamp cover is open. The lamp cover is not attached properly. Attach it properly.
Lit red	Lit amber after 90 seconds of flashing in amber	The lamp will not turn on. The lamp has reached end of life. Contact your reseller or ViewSonic for a replacement lamp.

Note:

Should the projector not project properly, see the Troubleshooting section of the User Guide.

FixYourDLP.com
 Sponsored by  DM
Discount-Merchant.com (800) 281-8860
THE TRUSTED SOURCE FOR PROJECTOR LAMPS AND ACCESSORIES

Replacing the Lamp Cartridge



WARNING

- The Lamp Cartridge should only be replaced after the unit has been turned off, cooled down for 60 minute and the power cord has been unplugged. Replacement of the lamp cartridge during operation or immediately after operation stops may cause burns due to high temperature.
- Do not remove any screws other those specified.
- Do not touch the lamp with bare hands. Doing so could shorten the life of the lamp.
- If the lamp has reached the end of its usable life, the lamp bulb may shatter. If the lamp shatters, contact ViewSonic Customer Support center immediately.

PREPARATION

To prevent scratches place the lamp on a soft cloth.

- 1 Disconnect the power cable.**
- 2 Turn the projector upside down.**
- 3 Remove the lamp cover.**

- (1) Turn the screw that fastens the lamp cover counterclockwise until it turns freely. (The screw will not come out.)

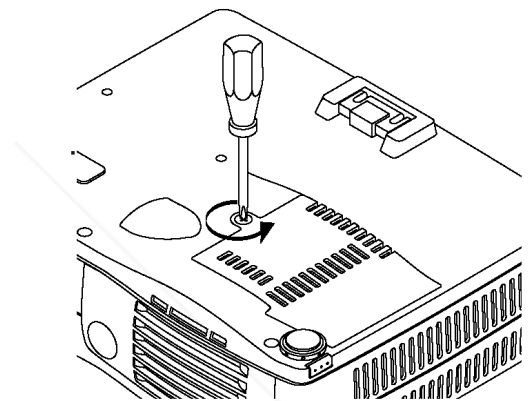

- (2) Lift the lamp cover a little and pull it off in the direction of the arrow.



Sponsored by DM

Discount-Merchant.com (800) 281-8860
THE TRUSTED SOURCE FOR PROJECTOR LAMPS AND ACCESSORIES

4 Remove the lamp cartridge.

- (1) Turn the 2 screws that fasten the lamp cartridge counterclockwise until they turn freely. (The screws will not come out.)

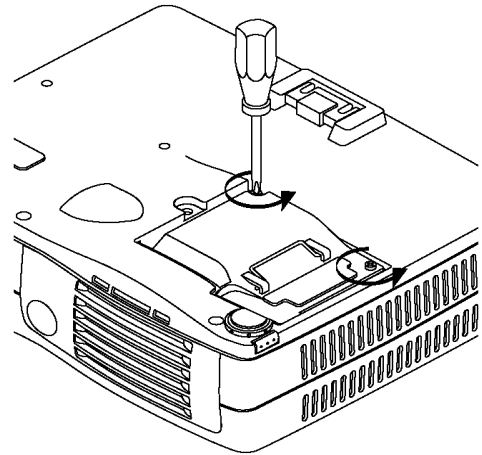

- (2) Grasp the handle of the lamp cartridge, pull it upward and remove the lamp cartridge.

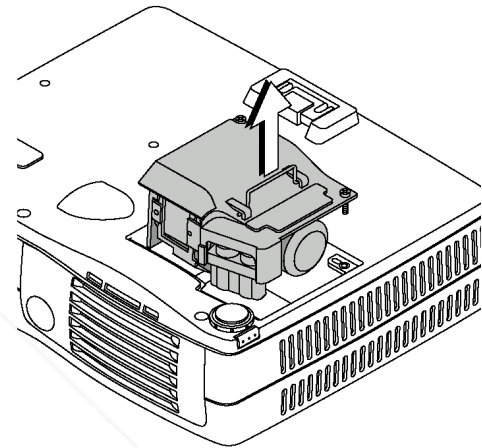

5 Install the new lamp cartridge.

- (1) Slowly push in the lamp cartridge with the socket facing forward. (Align the lamp cartridge screw with the screw hole of the projector.)
- (2) Turn the 2 screws of the lamp cartridge clock-wise to tighten.

6 Install the lamp cover.

- (1) First insert the front edge of the lamp cover into the groove, then close the lamp cover.
- (2) Turn the screw of the lamp cover clockwise to tighten.

7 Reset the lamp timer to zero.

Plug in the power cable and switch on the power before resetting.

Select [Info.] → [Lamp Timer Reset] and then reset the hours indication.

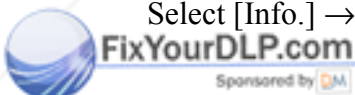

Discount-Merchant.com (800) 281-8860
THE TRUSTED SOURCE FOR PROJECTOR LAMPS AND ACCESSORIES

Specifications

Optical

DMD	Single Chip Digital Micro Device (DMD) 1024 x 768 dots, scaling to 1280 x 1024
Lamp	120 W high-pressure mercury lamp
Image size	36 inch to 200 inch

Electrical

Inputs	Video (NTSC3.58/NTSC4.43/PAL/PAL_N/PAL_M/PAL60/SECAM) RGB (Horizontal :15 to 85 kHz, Vertical 50 to 120 Hz)
Color Reproduction	Full color (16,770,000 colors)
Resolution	SXGA (Compression), XGA(True), SVGA/VGA (Expansion/True)
Input Current	1.8 A
Power Requirement	100-240 V AC, 50/60 Hz
Power Consumption	180 watts

Mechanical

Dimensions Excluding Stand	18.0 cm (W) x 4.5 cm (H) x 14.1 cm (D) 7.1 in.(W) x 1.8 in.(H) x 5.6 in.(D)
Weight	Approximately 1.0 kg / 2.20 lbs
Operational Temperatures	Data projector: 5° to 35°C (41° to 95°F), 30 to 85% humidity
Regulations	UL Approved (UL 1950, CSA 950) Meets FCC Class A requirements Meets EMC Directive (EN55022, EN55024) Meets Low Voltage Directive (EN60950)



* Specifications and design are subject to change without notice.



Discount-Merchant.com (800) 281-8860
THE TRUSTED SOURCE FOR PROJECTOR LAMPS AND ACCESSORIES

Distance Chart

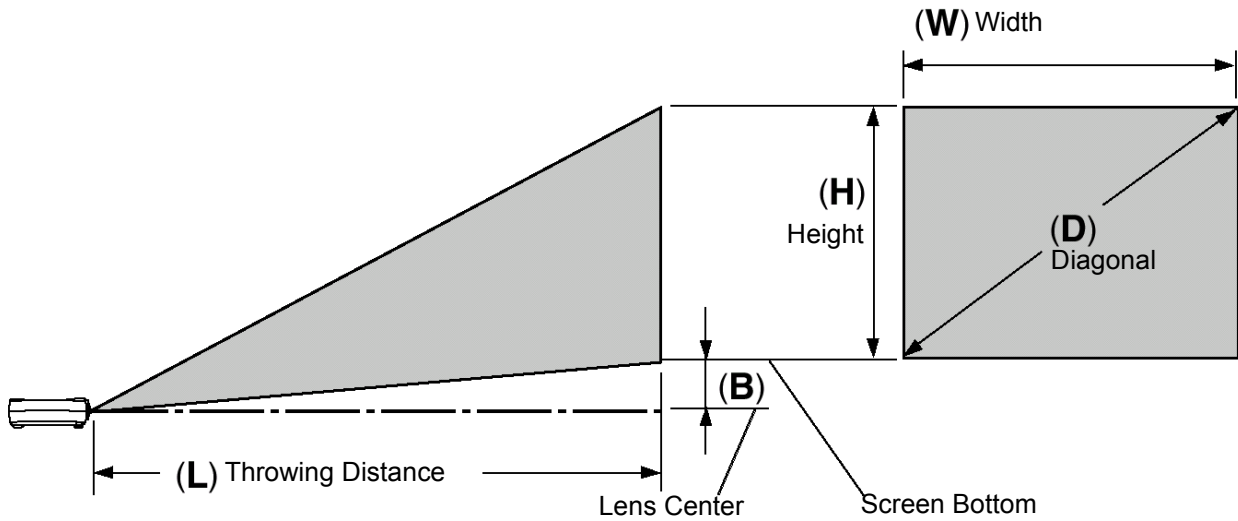

Screen Size		Projector distance from screen			
(D)		(W) x (H)		(L)	(B)
inch	mm	mm	mm	mm	mm
		inch	inch	inch	inch
36	914	732 x 549	28.8 x 26.1	1200 47.2	95 3.7
40	1016	813 x 610	32 x 24	1320 52.0	105 4.1
60	1524	1219 x 914	48 x 36	1990 78.3	157 6.2
80	2032	1626 x 1219	64 x 48	2650 104.3	209 8.2
100	2540	2032 x 1524	80 x 60	3310 130.3	262 10.3
120	3048	2438 x 1829	96 x 72	3970 156.3	314 12.3
150	3810	3048 x 2286	120 x 90	4970 195.7	393 15.5
180	4572	3658 x 2743	144 x 108	5960 234.6	472 18.6
200	5080	4064 x 3048	160 x 120	6620 260.6	524 20.6

FixYourDLP.com
Sponsored by DM

Discount-Merchant.com (800) 281-8860
THE TRUSTED SOURCE FOR PROJECTOR LAMPS AND ACCESSORIES

Cabinet Dimensions

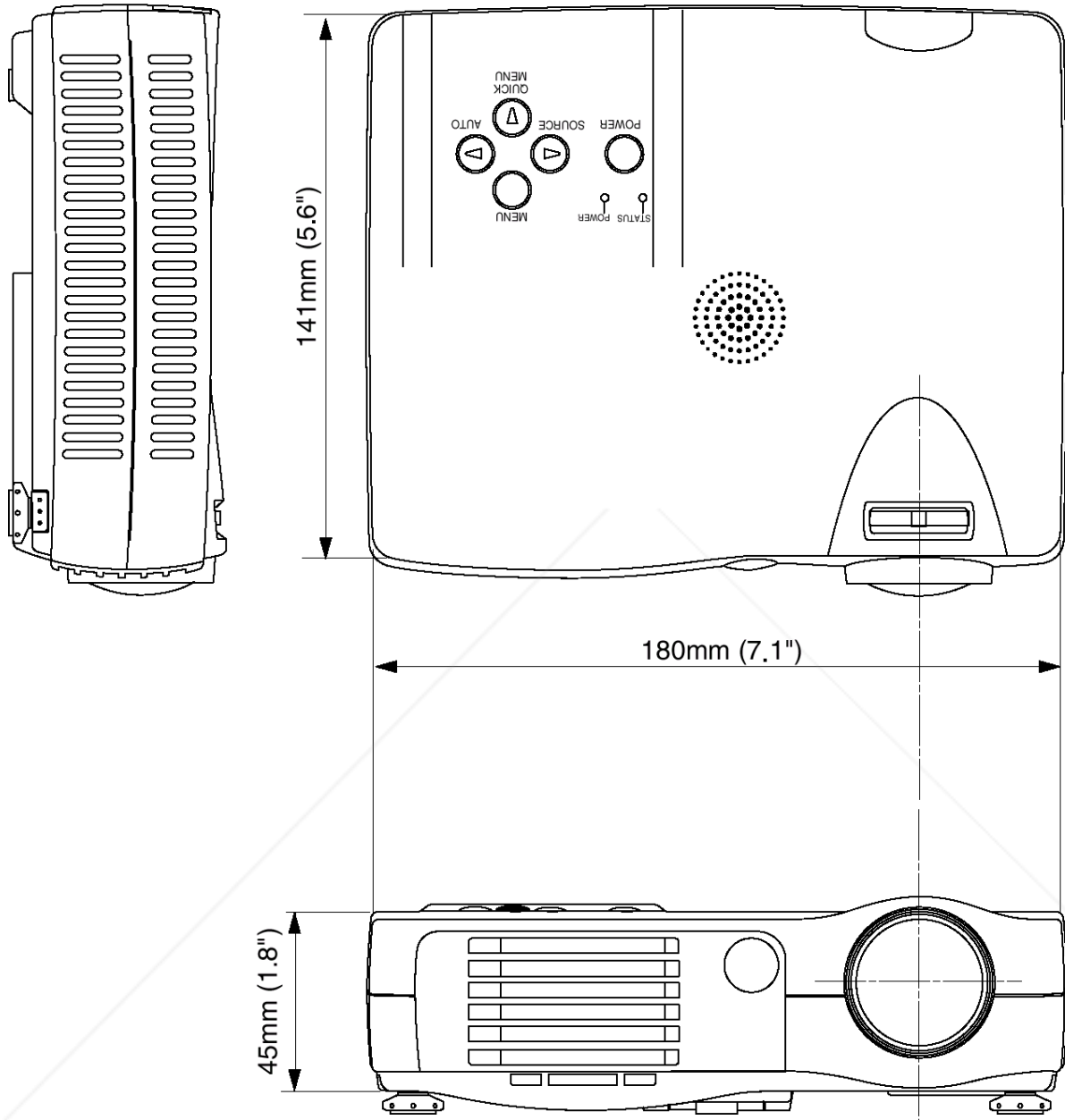

 **FixYourDLP.com**
Sponsored by 

Discount-Merchant.com (800) 281-8860
THE TRUSTED SOURCE FOR PROJECTOR LAMPS AND ACCESSORIES

Customer Support

For technical support or product service, please contact ViewSonic.

NOTE: You will need the product serial number.

Country/Region	Web site	T = Telephone F = FAX	Email
United States	viewsonic.com/ support	T: (800) 688-6688 F: (909) 468-1202	service.us@ viewsonic.com
Canada	viewsonic.com/ support	T: (800) 688-6688 F: (909) 468-1202	service.ca@ viewsonic.com
United Kingdom	viewsoniceurope.com	T: 0800 833 648 F: (01293) 643910	service.eu@ viewsoniceurope.com
Europe, Middle East, Baltic countries, and North Africa	viewsoniceurope.com	Contact your reseller	service.eu@ viewsoniceurope.com
Australia and New Zealand	viewsonic.com.au	T: +61 2 9929 3955 F: +61 2 9929 8393	service.au@ viewsonic.com
Singapore/India and Southeast Asia	viewsonic.com.sg	T: 65 273 4018 F: 65 273 1566	service.sg@ viewsonic.com
Other Asia/Pacific countries	viewsonic.com.tw	T: 886 2 2246 3456 F: 886 2 8242 3668	service.ap@ viewsonic.com
South Africa	viewsonic.com/asia	T: 886 2 2246 3456 F: 886 2 8242 3668	service.ap@ viewsonic.com



Discount-Merchant.com (800) 281-8860
THE TRUSTED SOURCE FOR PROJECTOR LAMPS AND ACCESSORIES

WARRANTY

VIEWSONIC PROJECTOR

What the warranty covers:

ViewSonic® warrants its products to be free from defects in material and workmanship during the warranty period. If a product proves to be defective in material or workmanship during the warranty period, **ViewSonic** will at its sole option repair or replace the product with a like product. Replacement product or parts may include remanufactured or refurbished parts or components.

How long the warranty is effective:

ViewSonic projectors are warranted for three (3) years for all parts excluding the lamp and three (3) years for all labor from the date of the first consumer purchase. Projector lamps are warranted separately.

Who the warranty protects:

This warranty is valid only for the first consumer purchaser.

What the warranty does not cover:

1. Any product on which the serial number has been defaced, modified or removed.
2. Damage, deterioration or malfunction resulting from:
 - a. Accident, misuse, neglect, fire, water, lightning, or other acts of nature, unauthorized product modification, or failure to follow instructions supplied with the product.
 - b. Repair or attempted repair by anyone not authorized by ViewSonic.
 - c. Any damage of the product due to shipment.
 - d. Removal or installation of the product.
 - e. Causes external to the product, such as electric power fluctuations or failure.
 - f. Use of supplies or parts not meeting ViewSonic's specifications.
 - g. Normal wear and tear.
 - h. Any other cause which does not relate to a product defect.
3. Removal, installation, and set-up service charges.

How to get service:

1. For information about receiving service under warranty, contact ViewSonic Customer Support. You will need to provide your product's serial number.
2. To obtain warranted service, you will be required to provide (a) the original dated sales slip, (b) your name, (c) your address, (d) a description of the problem, and (e) the serial number of the product.
3. Take or ship the product freight prepaid in the original container to an authorized ViewSonic service center or ViewSonic.
4. For additional information or the name of the nearest ViewSonic service center, contact ViewSonic.

Limitation of implied warranties:

THERE ARE NO WARRANTIES, EXPRESS OR IMPLIED, WHICH EXTEND BEYOND THE DESCRIPTION CONTAINED HEREIN INCLUDING THE IMPLIED WARRANTY OF MERCHANTABILITY AND FITNESS FOR A PARTICULAR PURPOSE.

Exclusion of damages:

VIEWSONIC LIABILITY IS LIMITED TO THE COST OF REPAIR OR REPLACEMENT OF THE PRODUCT. VIEWSONIC SHALL NOT BE LIABLE FOR:

1. DAMAGE TO OTHER PROPERTY CAUSED BY ANY DEFECTS IN THE PRODUCT, DAMAGES BASED UPON INCONVENIENCE, LOSS OF USE OF THE PRODUCT, LOSS OF TIME, LOSS OF PROFITS, LOSS OF BUSINESS OPPORTUNITY, LOSS OF GOODWILL, INTERFERENCE WITH BUSINESS RELATIONSHIPS, OR OTHER COMMERCIAL LOSS, EVEN IF ADVISED OF THE POSSIBILITY OF SUCH DAMAGES.
2. ANY OTHER DAMAGES, WHETHER INCIDENTAL, CONSEQUENTIAL OR OTHERWISE.
3. ANY CLAIM AGAINST THE CUSTOMER BY ANY OTHER PARTY.

Effect of state law:

This warranty gives you specific legal rights, and you may also have other rights which vary from state to state. Some states do not allow limitations on implied warranties and/or do not allow the exclusion of incidental or consequential damages. So the above limitations and exclusions may not apply to you.

Sales outside the U.S.A. and Canada:

For warranty information and service on ViewSonic products sold outside of the U.S.A. and Canada, contact ViewSonic or your local ViewSonic dealer.

Appendix

Power Cord Safety Guidelines

Caution: Use a power cable that is properly grounded. Always use an AC power cord that meets your country's safety standard.

USA..... UL	Switzerland SEV
Canada..... CSA	Britain.....BASE/BS
Germany..... VDE	

AC PLUG CORD PRECAUTIONS FOR THE UNITED KINGDOM

FOR YOUR SAFETY PLEASE READ THE FOLLOWING TEXT CAREFULLY.

IF THE FITTED MOULDED PLUG IS UNSUITABLE FOR THE SOCKET OUTLET THEN THE PLUG SHOULD BE CUT OFF AND DISPOSED OF SAFELY.

THERE IS A DANGER OF SEVERE ELECTRICAL SHOCK IF THE CUT OFF PLUG IS INSERTED INTO AN APPROPRIATE SOCKET.

If a new plug is to be fitted, please observe the wiring code as shown below.

If in any doubt, please consult a qualified electrician.

WARNING: THIS APPLIANCE MUST BE EARTHED.

IMPORTANT: The wires in this mains lead are coloured in accordance with the following code:

Green-and-Yellow:	Earth
Blue:	Neutral
Brown:	Live

If the coloured wires of the mains lead of this appliance do not correspond with the coloured markings identifying the terminals in your plug, proceed as follows:

The wire which is coloured GREEN-AND-YELLOW must be connected to the terminal in the plug which is marked by the letter E or by the Earth symbol or coloured GREEN or GREEN-AND-YELLOW.

The wire which is coloured BLUE must be connected to the terminal in the plug which is marked with the letter N or coloured BLACK. The wire which is coloured BROWN must be connected to the terminal in the plug which is marked with the letter L or coloured RED.

IMPORTANT NOTICE CONCERNING POWER CORD SELECTION

The power cord set for this unit has been enclosed and has been selected according to the country of destination and must be used to prevent electric shock. Use the following guidelines if it is necessary to replace the original cord set, or if the cord set is not enclosed.

The female receptacle of the cord set must meet CEE-22 requirements and may look like (Figure A1 below):

Figure 1 

For the United States and Canada

In the United States and Canada the male plug is a NEMA5-15 style (Figure A2), UL Listed, and CSA Labeled. For units which are mounted on a desk or table, type SVT cord sets may be used. The cord set must be selected according to the current rating for your unit. Please consult the table below for the selection criteria for power cords used in the United States and Canada.

Figure 2 

Cord Type	Size of Conductors in Cord	Maximum Current Rating of Unit
SVT	18 AWG	10 Amps

For European Countries

In Europe you must use a cord set which is appropriate for the receptacles in your country. The cord set is HAR-Certified, and a special mark that will appear on the outer sheath, or on the insulation of one of the inner conductors.

If you have any questions concerning which proper power cord to use, please consult with the dealer from whom you have purchased the product.

IMPORTANT SAFETY INFORMATION

Important Safeguards

These safety instructions are to maximize the long life of the unit and prevent fire and shock. Please read carefully.

Installation

- Place the unit on a flat, level surface in a dry area away from dust and moisture.
- Do not place the unit in direct sunlight, near heaters or heat radiating appliances.
- Exposure to direct sunlight, smoke or steam can harm internal components.
- Handle the unit carefully. Dropping or jarring can damage internal components.
- Do not place heavy objects on top of the unit.

Power Supply

- The unit is designed to operate on a power supply of 100-240 V 50/60 Hz AC. Ensure that your power supply fits these requirements before attempting to use the unit.
- Handle the power cable carefully and avoid excessive bending. A damaged cord can cause electric shock or fire.
- Disconnect the power cable from the power outlet after using the unit. Before disconnecting the power cable, make sure that the POWER indicator lights in amber (not blinking or in green).

Cleaning

- Disconnect the power cable from the unit.
- Clean the cabinet of the unit periodically with a damp cloth. If heavily soiled, use a mild detergent. Never use strong detergents or solvents such as alcohol or thinner.
- Use a blower or lens paper to clean the lens, and be careful not to scratch or mar the lens.
- Clean the ventilation slots and speaker grills on the unit periodically using a vacuum cleaner. If accumulated dust blocks the ventilation slots, the unit will overheat, which may cause the unit to malfunction. Use a soft brush attachment when using the vacuum cleaner. Do not use a hard attachment, such as a crevice tool, to prevent the damage to the unit.

Lamp Replacement

- Replace the lamp when the Status indicator comes on.
- Lamp may shatter at end of useful life. If lamp shatters contact ViewSonic immediately.

Fire and Shock Precautions

- Ensure that there is sufficient ventilation and that vents are unobstructed to prevent the buildup of heat inside the unit. Allow at least 10 cm (3 inches) of space between the unit and walls.
- Prevent foreign objects, such as paper clips and bits of paper, from falling into the unit. Do not attempt to retrieve any objects that fell into the unit. Do not insert any metal objects such as a wire or screwdriver into the unit. If something should fall into the unit, immediately disconnect the power cable from the unit and have the object removed by a qualified service technician.
- Do not place any liquids on top of the unit.

Do not look into the lens while the unit is on, or serious damage to your eyes may result.

Portability

- When carrying the unit around, please use the carrying case included and, to protect the lens from scratches, always use the lens cap. Also, do not subject the unit to strong mechanical shock.



FixYourDLR.com
Sponsored by DM

Discount-Merchant.com (800) 281-8860
THE TRUSTED SOURCE FOR PROJECTOR LAMPS AND ACCESSORIES

Compliance Information for U.S.A.

This equipment has been tested and found to comply with the limits for a Class A digital device, pursuant to part 15 of the FCC Rules. These limits are designed to provide reasonable protection against harmful interference. This equipment generates, uses, and can radiate radio frequency energy, and if not installed and used in accordance with the instructions, may cause harmful interference.

WARNING

This is a class A product. In a domestic environment this product may cause radio interference in which case the user may be required to take adequate measures.

RF Interference WARNING

The Federal Communications Commission does not allow any modifications or changes to the unit EXCEPT those specified by ViewSonic in this manual. Failure to comply with this government regulation could void your right to operate this equipment. This equipment has been tested and found to comply with the limits for a Class A digital device, pursuant to Part 15 of the FCC Rules. These limits are designed to provide reasonable protection against harmful interference when the equipment is operated in a commercial environment. This equipment generates, uses, and can radiate radio frequency energy and, if not installed and used in accordance with the instruction manual, may cause harmful interference to radio communications. Operation of this equipment in a residential area is likely to cause harmful interference in which case the user will be required to correct the interference at his own expense.

FCC Warning

To assure continued FCC compliance, the user must use grounded power supply cord and the provided shielded video interface cable with bonded ferrite cores. If a BNC cable is going to be used, use only a shielded BNC(5) cable. Also, any unauthorized changes or modifications not expressly approved by the party responsible for compliance could void the user's authority to operate this device.

Instructions to Users

This equipment complies with the requirements of FCC (Federal Communication Commission) equipment provided that the following condition is met. Use the cables which are included with the projector or specified.

Compliance Information for Canada

Notice: This class A digital apparatus complies with Canada ICES-003.

Compliance Information for European Countries

CE Conformity



The device complies with the requirements of the EEC directive 89/336/EEC as amended by 92/31/EEC and 93/68/EEC Art.5 with regard to "Electromagnetic compatibility," and 73/23/EEC as amended by 93/68/EEC Art.13 with regard to "Safety."

User Information for all Countries

NOTICE: Use the cables which are included with the projector or specified.



Discount-Merchant.com (800) 281-8860
THE TRUSTED SOURCE FOR PROJECTOR LAMPS AND ACCESSORIES



Disclaimer

This user manual is provided as a free service by FixYourDLP.com. FixYourDLP is in no way responsible for the content of this manual, nor do we guarantee its accuracy. FixYourDLP does not make any claim of copyright and all copyrights remain the property of their respective owners.

About FixYourDLP.com

FixYourDLP.com (<http://www.fixyourdlp.com>) is the World's #1 resource for media product news, reviews, do-it-yourself guides, and manuals.

Informational Blog: <http://www.fixyourdlp.com>

Video Guides: <http://www.fixyourdlp.com/guides>

User Forums: <http://www.fixyourdlp.com/forum>

FixYourDLP's Fight Against Counterfeit Lamps:

<http://www.fixyourdlp.com/counterfeits>

Sponsors:

RecycleYourLamp.org – Free lamp recycling services for used lamps:

<http://www.recycleyourlamp.org>

Lamp Research - The trusted 3rd party lamp research company:

<http://www.lampresearch.com>

Discount-Merchant.com – The worlds largest lamp distributor:

<http://www.discount-merchant.com>



FixYourDLP.com

Sponsored by 