



Disclaimer

This user manual is provided as a free service by FixYourDLP.com. FixYourDLP is in no way responsible for the content of this manual, nor do we guarantee its accuracy. FixYourDLP does not make any claim of copyright and all copyrights remain the property of their respective owners.

About FixYourDLP.com

FixYourDLP.com (<http://www.fixyourdlp.com>) is the World's #1 resource for media product news, reviews, do-it-yourself guides, and manuals.

Informational Blog: <http://www.fixyourdlp.com>

Video Guides: <http://www.fixyourdlp.com/guides>

User Forums: <http://www.fixyourdlp.com/forum>

FixYourDLP's Fight Against Counterfeit Lamps:

<http://www.fixyourdlp.com/counterfeits>

Sponsors:

RecycleYourLamp.org – Free lamp recycling services for used lamps:

<http://www.recycleyourlamp.org>

Lamp Research - The trusted 3rd party lamp research company:

<http://www.lampresearch.com>

Discount-Merchant.com – The worlds largest lamp distributor:

<http://www.discount-merchant.com>



FixYourDLP.com

Sponsored by 

Operating Instructions

LCD Projector

Model PT-L292U

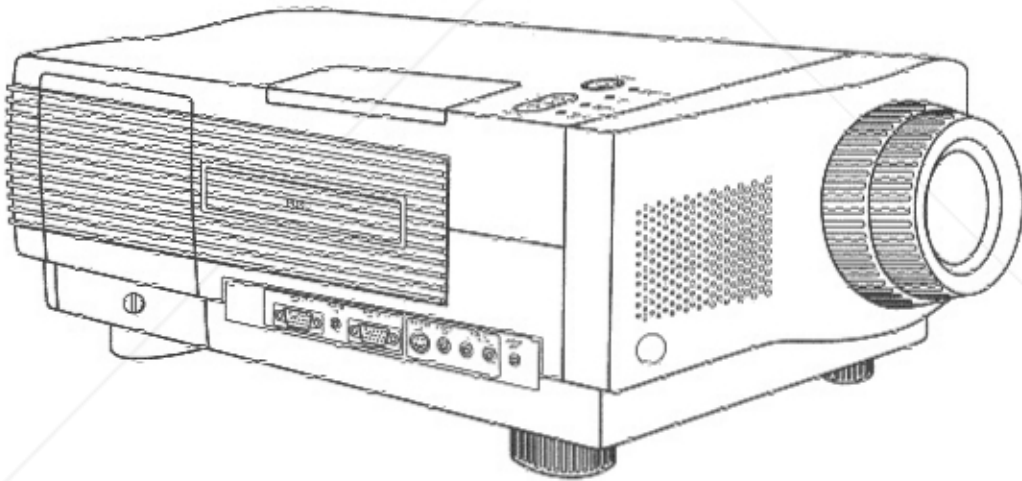

 FixYourDLP.com
Sponsored by 

Discount-M **Panasonic** (800) 281-8860

THE TRUSTED SOURCE FOR PROJECTOR LAMPS AND ACCESSORIES

Please read these completely before operating this LCD Projector.

Things You Should Know

Caution: This equipment has been tested and found to comply with the limits for a Class B digital device, pursuant to Part 15 of the FCC Rules. These limits are designed to provide reasonable protection against harmful interference in a residential installation. This equipment generates, uses, and can radiate radio frequency energy and, if not installed and used in accordance with the instructions, may cause harmful interference to radio communications. However, there is no guarantee that interference will not occur in a particular installation. If this equipment does cause harmful interference to radio or television reception, which can be determined by turning the equipment off and on, the user is encouraged to try to correct the interference by one or more of the following measures:

- Reorient or relocate the receiving antenna.
- Increase the separation between the equipment and receiver.
- Connect the equipment into an outlet on a circuit different from that to which the receiver is connected.
- Consult the dealer or an experienced radio/TV technician for help.

FCC Warning: To assure continued compliance, use only the provided grounded power supply cord and shielded interface cable with ferrite core when connecting this device to a computer. Also, any unauthorized changes or modifications to this equipment could void the user's authority to operate this device.

Congratulations

on your purchase of one of the most sophisticated and reliable products on the market today. Used properly, we're sure it will bring you and your family years of service enjoyment. Please take time to fill in the information below. The serial number is on the tag located on the back of your LCD Projector. You'll want to keep this manual handy as your convenient LCD Projector information source. For your own protection and prolonged operation of your LCD Projector, please be sure to read the "Important Safeguards" carefully, before use.

Date of Purchase _____
Dealer Purchased From _____
Dealer Address _____
Dealer Phone No. _____
Model No. **PT-L292U** _____
Serial No. _____

Table of Contents

Things You Should Know	1
Important Safeguards	2, 3
Contents of LCD Projector Box	4
LCD Projector Features	5, 6
Product Information	7, 8
Positioning the LCD Projector and Screen	9
Initial Set Up of the LCD Projector	10
Specifications	11
Video/Computer Cables & Adaptors	12
Pin Assignment	12
Connecting the LCD Projector	13, 14, 15, 16
Basic LCD Projector Operation	17, 18
Video Adjustment	19, 20, 21, 22
Timing Specifications	23
Factory Preset Timing	24, 25
Maintenance	26, 27, 28
Trouble Shooting	29, 30, 31

© 1997 Matsushita Electric Industrial Co., Ltd

All product/brand names are trademarks or registered trademarks of the respective holders.

Important Safeguards



CAUTION: Please read all of these instructions before you operate your LCD Projector. Save these instructions for future reference.

Electrical energy can perform many useful functions. This LCD Projector has been engineered and manufactured to meet applicable safety standards. But IMPROPER USE CAN RESULT IN POTENTIAL ELECTRICAL SHOCK OR FIRE HAZARDS. In order not to defeat the safeguards incorporated into this LCD Projector, observe the following basic rules for its installation, use and servicing.

- 1 Unplug the LCD Projector from the wall outlet before cleaning.
- 2 Do not use liquid cleaners or aerosol cleaners. Use a soft dry cloth to clean the LCD Projector unit. If the unit is very dirty, wet a cloth with neutral detergent, squeeze it tight, wipe the unit with it, and finish by wiping with a dry cloth. Do not use a chemical duster or polisher-cleaner because it can adversely affect the unit and peel the paint coat.
- 3 Do not use attachments not recommended by Panasonic, as they may cause hazards.
- 4 Do not use the LCD Projector near water; for example, near a bathtub, washbowl, kitchen sink, laundry tub, in a wet basement, near a swimming pool, etc. Never spill liquid into the LCD Projector.
- 5 Do not place the LCD Projector on an unstable cart, stand, or table. The LCD Projector may fall, which may cause serious injury to a child or an adult, and/or serious damage to the unit. Use only with a cart or stand recommended by its manufacturer, as being suitable for use with an LCD Projector.
- 6 Ceiling, wall or shelf mounting for installation should use a mounting kit approved by the manufacturer for use with an LCD Projector and should follow the manufacturer's instructions.
- 7 LCD Projector equipment and cart combinations should be moved with care. Quick stops, excessive force, and uneven surfaces may cause the equipment and cart combination to overturn.
- 8 Slots and openings in the cabinet back and bottom are provided for ventilation. To ensure reliable operation of the LCD Projector and to protect it from overheating, these openings must not be blocked or covered. These openings should never be covered with cloth or other material. The bottom opening should not be blocked by placing the LCD Projector on a bed, sofa, rug, or other similar surface. The LCD Projector should not be placed near or over a radiator or heating vent. The LCD Projector should not be placed in a built-in installation such as a bookcase unless proper ventilation is provided.
- 9 The LCD Projector should be operated only from the type of power source indicated on the back of the LCD Projector or in the specifications. If you are not sure of the type of power supplied to your home, consult your LCD Projector dealer or local power company.
- 10 Do not allow anything to rest on the power cord. Do not place the LCD Projector where the cord will be walked on.
- 11 Follow all warnings and instructions marked on the LCD Projector.
- 12 As a safety feature, this LCD Projector is equipped with a 3-prong grounded plug. The 3-prong grounded plug will fit only into a grounding type power outlet. If the plug does not fit, use an adaptor that is properly grounded or have an electrician install a grounded type outlet. Do not attempt to modify this AC plug.
- 13 For added protection of the LCD Projector during a lightning storm, or when it is left unattended or not in use for long periods of time, unplug it from the wall outlet and disconnect any cable systems. This will prevent damage to the projector due to lightning and power-line surges.
- 14 Do not overload wall outlets and extension cords with too many products, because this can result in fire or electric shock.



FixYourDLP.com
Sponsored by DM

DISCOUNT ELECTRONICS
THE TRUSTED SOURCE FOR PROJECTOR LAMPS AND ACCESSORIES

- 15** Never push objects of any kind into the LCD Projector through cabinet slots as they may touch dangerous voltage points or short out parts, which could result in a fire or electric shock.
- 16** Do not attempt to service the LCD Projector yourself. Opening or removing covers may expose you to dangerous voltage or other hazards. Refer all servicing to qualified service personnel.
- 17** Unplug the LCD Projector equipment from the wall outlet and refer servicing to qualified service personnel under the following conditions:
 - A. When the power cord or plug is damaged or frayed.
 - B. If liquid has been spilled into the LCD Projector.
 - C. If the LCD Projector has been exposed to rain or water.
 - D. If the LCD Projector does not operate normally when you follow the operating instructions. Adjust only those controls that are covered by the operating instructions; improper adjustment of other controls may cause damage and will often require extensive work by a qualified technician to restore the LCD Projector to normal operation.
 - E. If the LCD Projector has been dropped or the cabinet has been damaged.
 - F. When the LCD Projector exhibits a distinct change in performance – this indicates a need for service.
- 18** Upon completion of any service or repairs to the LCD Projector, ask the service technician to perform a routine safety check to determine that the LCD Projector is in safe operating condition.
- 19** When replacement parts are required, be sure the service technician has used replacement parts specified by the manufacturer that have the same characteristics as the original parts. Unauthorized substitutions may result in fire, electric shock, or other hazards.
- 20** Air filter must be cleaned every 100 lamp on hours.
LCD Projector may become too hot if filter is not cleaned when required.
- 21** If lens becomes dirty, or smudged, clean with a clean, dampened cloth. Never touch the lens with your fingers.
- 22** Do not look directly into the aperture and lens while operating as this may result in damage to your eyes.



Discount-Merchant.com (800) 281-8860
THE TRUSTED SOURCE FOR PROJECTOR LAMPS AND ACCESSORIES

Contents of LCD Projector Box

Please confirm that the following items are packed in the LCD Projector box. They are provided to help you use or set up your LCD Projector.

- (1) LCD Projector
- (2) Remote Control
- (3) 2 "AA" Batteries
- (4) 9.8 Foot UL/CSA Power Cord
- (5) VGA Cable
- (6) VGA MAC13" Adaptor
- (7) VGA MAC16" Adaptor
- (8) PC Audio Cable
- (9) Video RCA Cable
- (10) RCA - BNC pin Adaptor
- (11) Audio RCA Cable
- (12) Operating Instructions (Please read completely before operating.)
- (13) Warranty Card
- (14) Service Center List



Discount-Merchant.com (800) 281-8860
THE TRUSTED SOURCE FOR PROJECTOR LAMPS AND ACCESSORIES

LCD Projector Features

1 High Brightness and Resolution

1,558k-pixel, 300-lumen (ANSI) offers clear images even when ambient light level is high.

2 Compact and Lightweight

Completely portable, you can give attractive presentations at any location by connecting the PT-L292U to a notebook computer, etc.

3 20 to 300 Inch Screen Capability

30" (2.5 feet) to 650" (54.2 feet) throw distance. (See table on page 9.)

4 Compatible with Most Personal Computers

The RGB input accepts signals from VGA, SVGA, XGA (Compression), and MAC compatible computers with no additional hardware. Other compatible computers require a separate cable.

5 Accommodates 6 different video signal standards

This LCD Projector accepts the input signal of all major video formats, including PAL, SECAM, NTSC, PAL-M, PAL-N, NTSC4.43, and the higher quality S-Video signals.

6 Rear Screen Projection

The LCD Projector is equipped with a reverse scan function which allows the image to be reversed for rear projection. (See operation on page 18.)

(Front Projection)

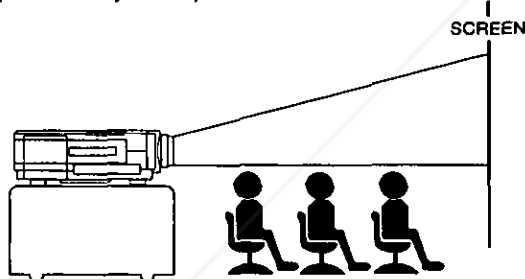

(Rear Projection)

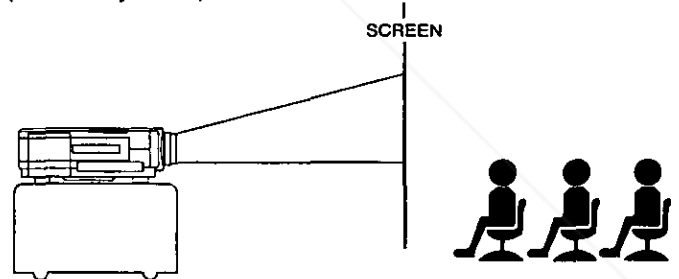

7 IR Remote Control

Front and rear sensors allow you to control the projector from almost anywhere in the room.

8 Stereo Audio Output

For external audio equipment connection. Audio follows video source.



FixYourDLP.com

Sponsored by DM

Discount-Merchant.com (800) 281-8860
THE TRUSTED SOURCE FOR PROJECTOR LAMPS AND ACCESSORIES

9 Blue Screen with No Input Signal

The LCD Projector is equipped with an internal Blue Screen function which turns the screen blue when the video or computer equipment connected to the input jack is turned off, or when there is nothing connected to the input jack.

- If the power is turned on when no input signal is input to the LCD Projector, the screen will turn blue. The "FOCUS" overlay appears only until the video or computer equipment is connected to the input jack and turned on. If no input signal is received (the screen is blue) for 15 minutes, the lamp will turn off automatically.

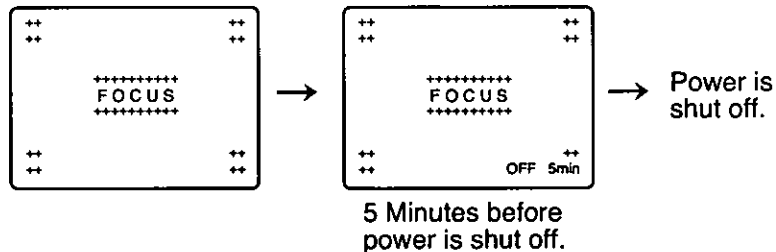

- The following display will appear when the RGB input is within the LCD Projector's frequency range, but is not one of the LCD Projector's programmed formats. (As found on pages 24, 25.)
- Should an RGB signal be input which is out of the LCD Projector's frequency range, no indication will be present.

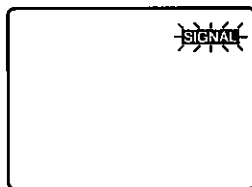

10 Manual Shutter Function

Blanks out the screen and mutes the sound.

Press the SHUTTER button or key to blank the video to black and mute the audio.

Press the button or key once again to return to the normal screen and sound.

11 Audio Mute

Press the MUTE button or key to instantly mute the sound.

Press again to restore the previous sound level.

12 On Screen Displays

Information screens and menus make setting up and operating the LCD Projector extremely easy.

13 Automatic Universal Power Supply with Automatic Power Down

This unit has an operating voltage range of AC 100 - 240V. The lamp power is automatically turned off if there is no Input Signal for 15 minutes.

Discount-Merchant.com (800) 281-8860
THE TRUSTED SOURCE FOR PROJECTOR LAMPS AND ACCESSORIES

Product Information

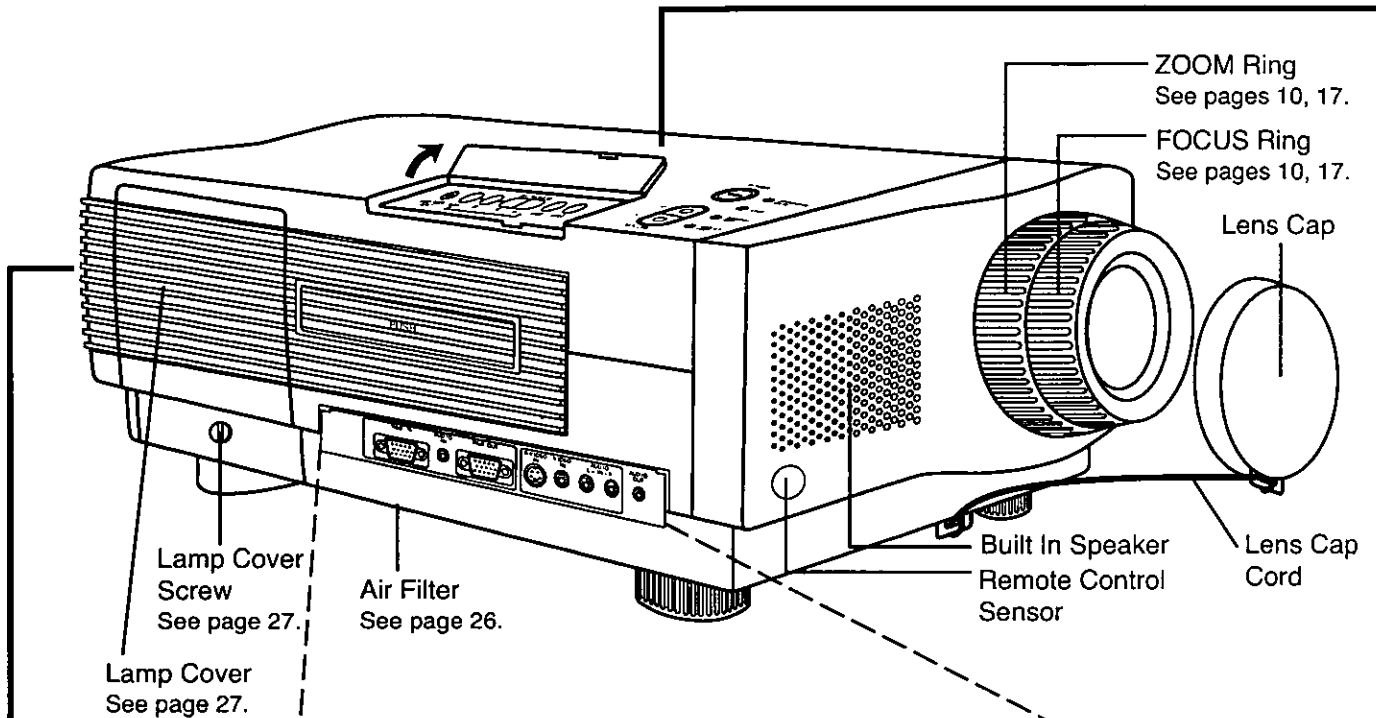

Side View

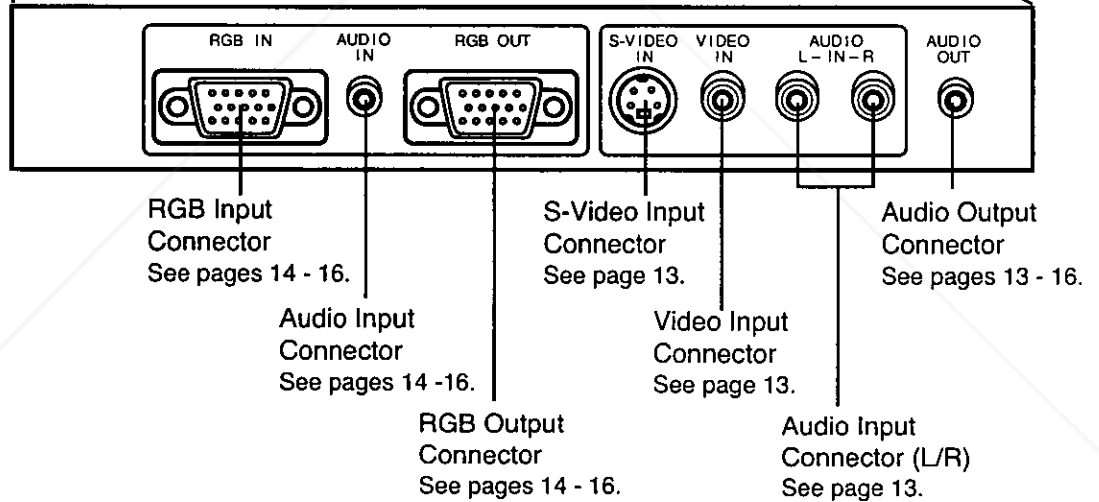

Rear View

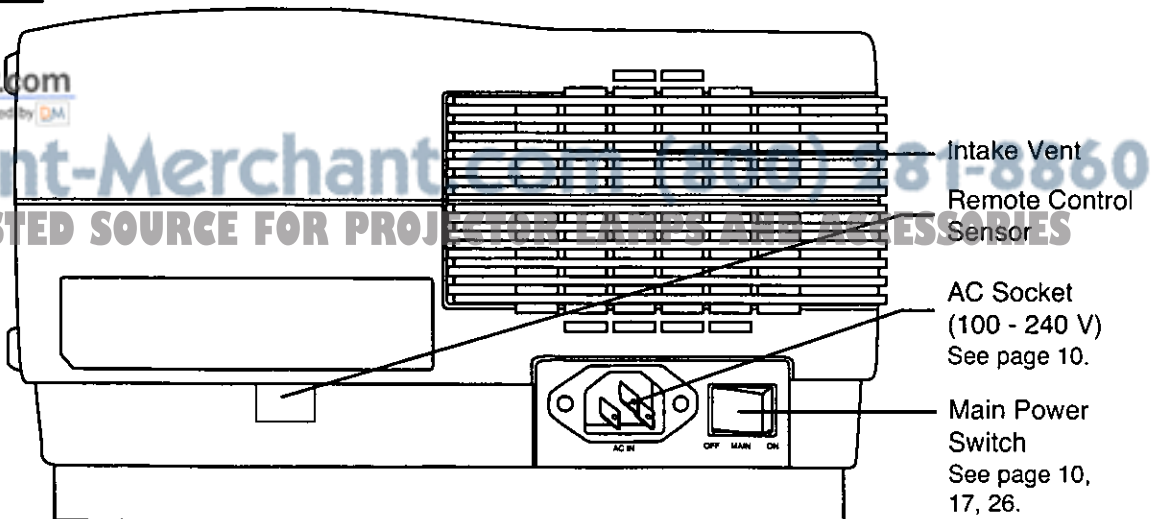

FixYourDLP.com
 Sponsored by DM

Discount-Merchant.com (800) 581-8860
 THE TRUSTED SOURCE FOR PROJECTOR LAMPS AND ACCESSORIES

Top View

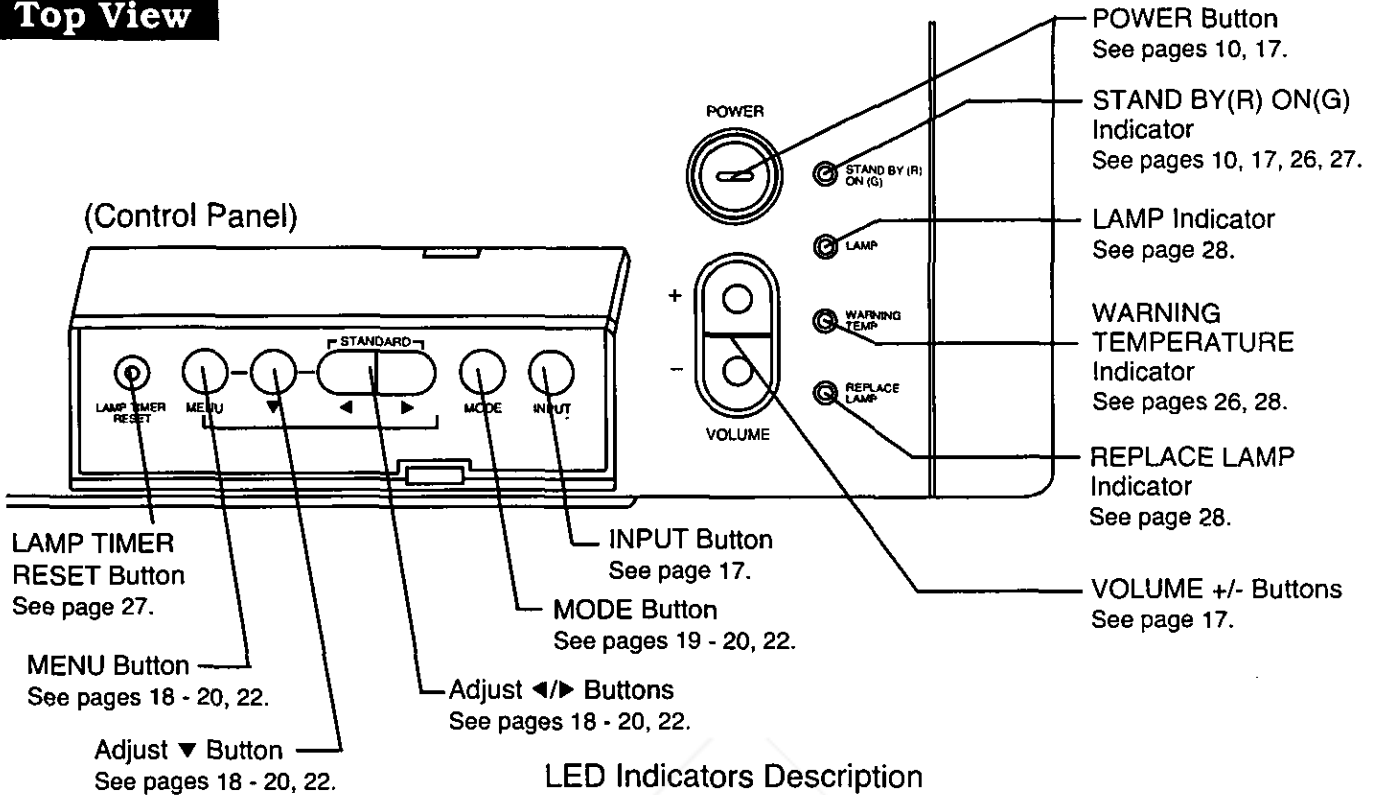

LED Indicators Description

STAND BY(R) ON(G)	RED = Power On Flashing RED = Cooling Fan GREEN = Lamp On Flashing GREEN = Warming Up
LAMP	RED = Error
WARNING TEMP	RED Flashing = Temperature Error
REPLACE LAMP	RED Flashing > 1,000 hrs RED ≥ 1,100 hrs

REMOTE CONTROL

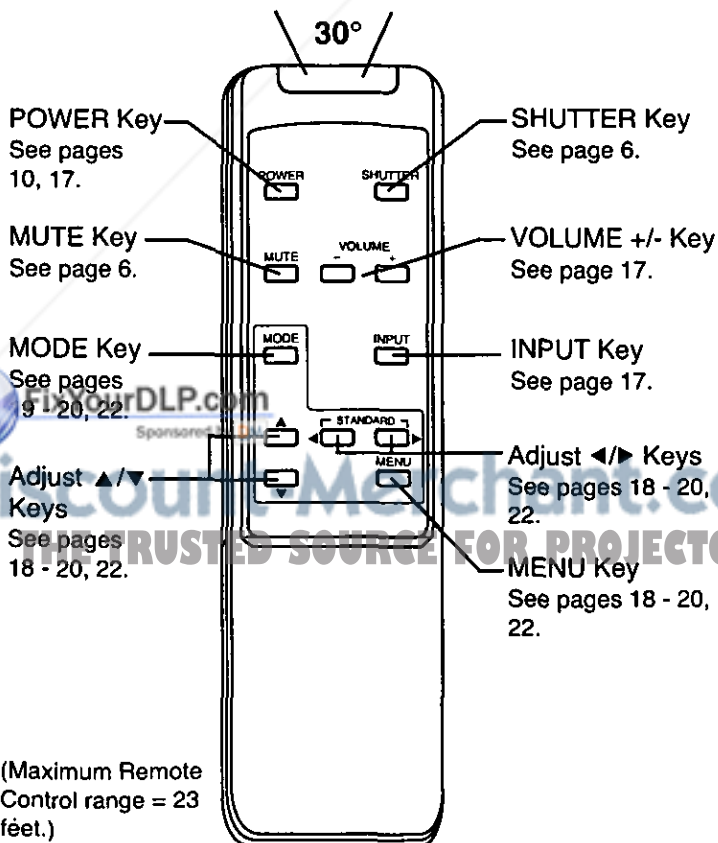

Load the 2 "AA" batteries in the Remote Control

1 Slide the lid in the direction of the arrow.

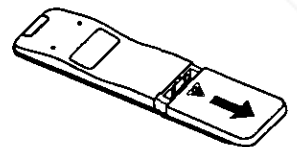

2 Install 2 "AA" batteries as indicated inside the Battery Compartment.

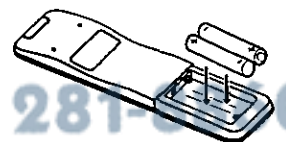

3 Replace the lid and snap into place.

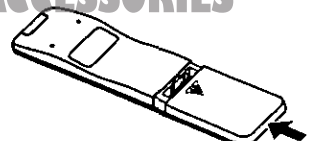

Battery replacement caution

- Do not mix old and new batteries. (Also never mix alkaline with manganese batteries.)

Positioning the LCD Projector and Screen

The screen should be positioned so that it is not directly touched by sunlight or room light as this will wash out the colors of the picture making it hard to see. When possible, close all blinds, curtains, etc. and dim the lights. Also, the LCD Projector should be at a 90° angle to the screen for the best picture results. To determine the distance for the desired size, please refer to the LCD Projector/Screen Relationship Chart below.

Top View

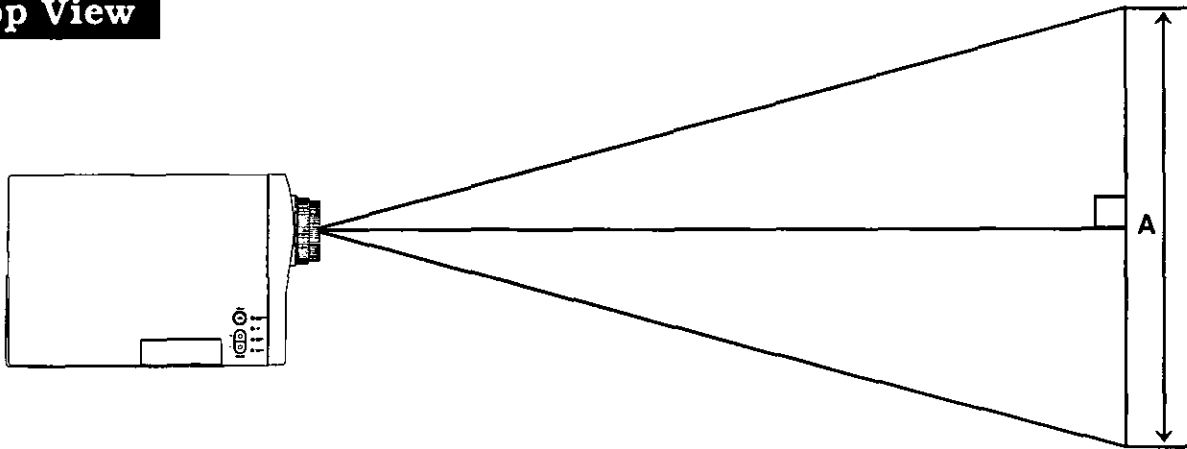

Side View

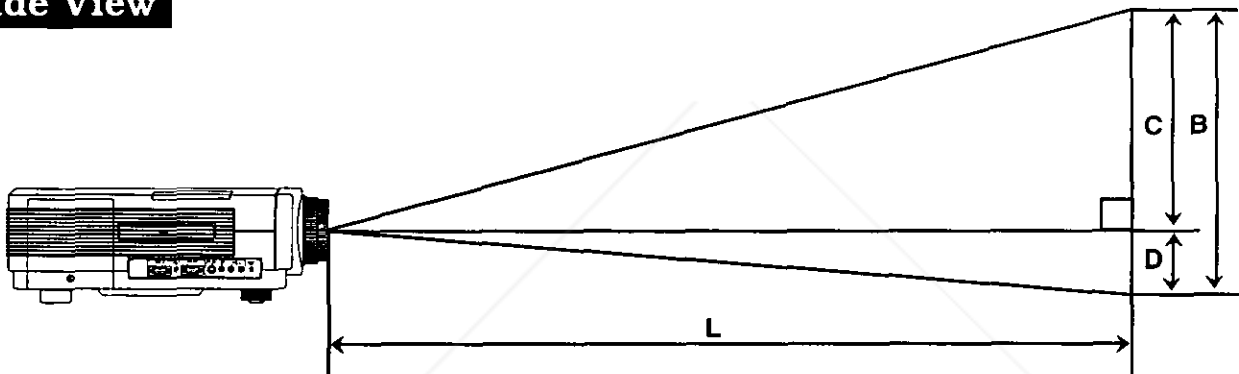

- Your LCD Projector is equipped with an image reverse feature. So, in addition to front projection, you can also reverse the image for rear projection. (See page 18.)

LCD Projector /Screen Relative Position Chart

The picture can be adjusted to the desired size within the range of the zoom lens.
(This chart is based on SVGA input signal. Screen sizes will be smaller when VGA signal is used.)

Screen size	Throw distance (L)	Measure (A)	Measure (B)	Measure (C)	Measure (D)
20 inches	2.46 – 3.61 ft (0.75 – 1.1 m)	1.35 ft (0.41 m)	0.98 ft (0.3 m)	0.89 ft (0.27 m)	1.18 in. (3 cm)
40 inches	4.92 – 7.22 ft (1.5 – 2.2 m)	2.66 ft (0.81 m)	2.00 ft (0.61 m)	1.80 ft (0.55 m)	2.36 in. (6 cm)
60 inches	7.55 – 10.83 ft (2.3 – 3.3 m)	3.94 ft (1.2 m)	2.99 ft (0.91 m)	2.69 ft (0.82 m)	3.54 in. (9 cm)
80 inches	9.84 – 14.44 ft (3.0 – 4.4 m)	5.25 ft (1.6 m)	3.94 ft (1.2 m)	3.54 ft (1.08 m)	4.72 in. (12 cm)
100 inches	12.47 – 18.04 ft (3.8 – 5.5 m)	6.56 ft (2.0 m)	4.92 ft (1.5 m)	4.43 ft (1.35 m)	5.91 in. (15 cm)
200 inches	24.93 – 36.09 ft (7.6 – 11.0 m)	13.45 ft (4.1 m)	9.84 ft (3.0 m)	8.86 ft (2.7 m)	11.81 in. (30 cm)
300 inches	37.40 – 54.13 ft (11.4 – 16.5 m)	20.01 ft (6.1 m)	15.09 ft (4.6 m)	13.58 ft (4.14 m)	18.11 in. (46 cm)

- If the LCD Projector and the screen are not properly placed, the picture will be distorted producing a keystone image as shown at right.

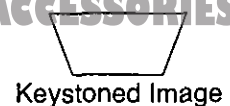

Caution: When you set up the LCD Projector

- Do not place it in humid or dusty places, or places where the air is sooty or full of cigarette smoke. If the lens, mirror, or other optical components become dirty, the picture will blur or darken, making viewing difficult.
- Do not expose to extreme heat or cold. Operating temperature: 5°C – 40°C (41°F – 104°F)

Initial Set Up of the LCD Projector

Place the LCD Projector on a stable, flat surface according to the LCD Projector/ Screen Relative Position Chart on page 9.

- Remove the lens cap.

1 Insert Power Cord into LCD Projector AC socket and connect to properly grounded wall outlet.

2 Set the Main Power Switch to ON.

- The STAND BY(R) ON(G) indicator lights red.
(It takes about 45 seconds for image to appear clearly.)

3 Press POWER on the LCD Projector or remote control ON.

- The STAND BY(R) ON(G) indicator changes to green.

4 Use the FOCUS and ZOOM Rings
to adjust the focus and size of the image.

5 Use the Height/ Level Adjusters

to adjust the vertical angle of the projector as specified on page 9. (See illustration below.)

6 Use the FOCUS and ZOOM Rings
to readjust the focus and size of the image.

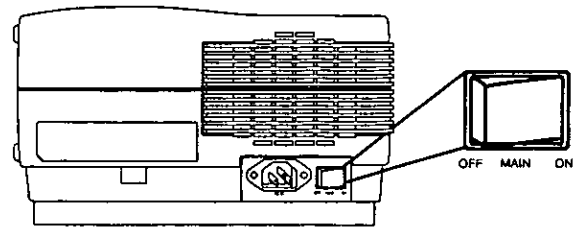

Side View

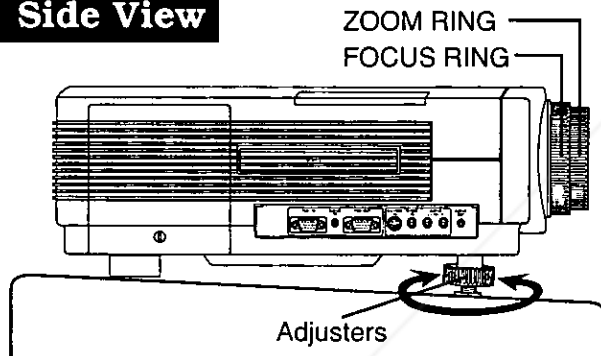

Center the projected image on the screen.

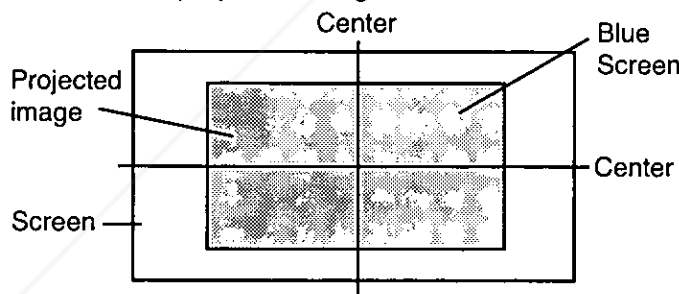

Front View

To Raise:
turn adjusters
in direction of
arrows.

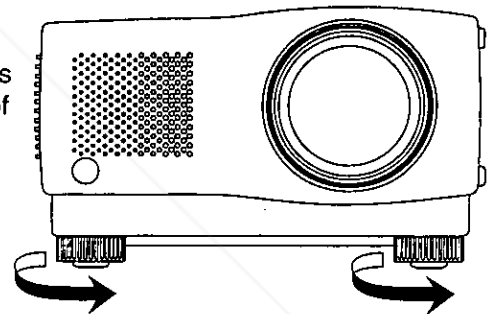

To Lower:
turn adjusters
in direction of
arrows.

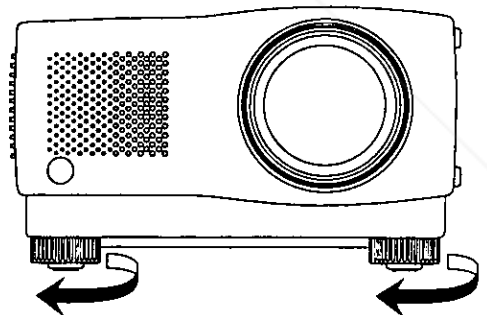

Notes:

- When adjustments are made improperly, the picture may become distorted, depending on the relative positions of the LCD Projector and the screen.
- To prevent the LCD Projector from wobbling, adjust both adjusters so that they firmly contact the mounting surface.

Moving the LCD Projector

First, turn Main Power Switch OFF and disconnect Power Cord. Second, disconnect all other cables.

Press in on handle to release or store handle.

- Make sure the lens cap is in place to prevent damage to the lens.

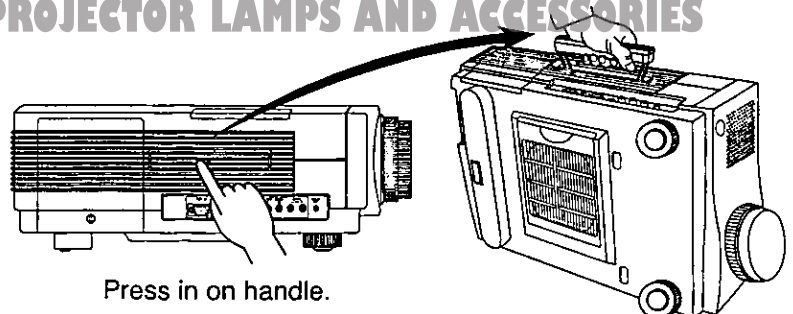

Specifications

LCD panels		1.3" Poly silicon LCD panel X3, RGB shutter method, using Translucent TN crystal panels
Drive method		Active Matrix 4:3 Aspect Ratio panels, TFT (Thin Film Transistor)
No. of pixels		1,557,504 stripe pixels (832 X 624 X 3)
Lens		1 - 1.44 zoom lens, F2.8 - 3.1, f 50 - 72mm Manual Focus
Projector lamp		Metal halide 250W
Contrast ratio		150 : 1
Brightness		300 lumen / ANSI
Colors		16,777,216
Screen size		20" - 300" (measured diagonally)
Projection (throw) distance		2.5' - 54.2'
Keystone Correction		1 : 9 Low position
Video input signal		PAL/SECAM/NTSC/PAL-M/PAL-N Composite video, 1 Vp-p, sync negative, 75Ω terminated
S-Video input signal		Y (luminance signal) : 1 Vp-p, sync negative, 75Ω terminated C (chrominance signal) : burst 0.286 Vp-p, 75Ω terminated
RGB input signal	Video signal	RGB Analog (0.7 Vp-p, 1.0 Vp-p with sync on green, 75Ω) Unlimited numbers of colors
	Sync signal	H/V separate, H/V combined, or Sync-on-Green
	H-Frequency	24.83 - 56.48 KHz (TTL Level) ← Refer to pages 24, 25.
	V-Frequency	56.25 - 85.1 Hz (TTL Level) ← Refer to pages 24, 25.
Terminals		PAL/SECAM/NTSC/PAL-M/PAL-N Video Input : One RCA jack S-Video Input : One 4-pin mini DIN connector Computer Display Input: One 15 pin mini D-Sub Computer Display Output: One 15 pin mini D-Sub Video Audio Input : 2 RCA jacks (L + R) Computer Audio Input : M3 stereo jack Through Audio output : M3 stereo jack
Controls	Cabinet Buttons/ Switches	Main Power ON/OFF, Power ON/OFF, Volume +/-
	Buttons under the cover	Mode, Input, Menu, ▼, ◀, ▶, Lamp Timer Reset
	Remote Control Keys	Power ON/OFF, Volume +/-, Shutter, Mute, Mode, Input Menu, ▲, ▼, ◀, ▶
Audio output		1.5 W
Speaker		3.1" round X 1
Operating Temperature		41°F to 104°F (5°C to 40°C)
Operating Humidity		10% - 80 % (non-condensation)
Storage Temperature		-13°F to 140°F (-25°C to 60°C)
Storage Humidity		5% - 85% (non-condensation)
Power Supply		100 - 240 V AC (50 or 60 Hz) Automatic
Power Consumption		390 W
Dimensions W X H X D		11 - 7/16" X 6 - 7/8" X 19" (290 X 175 X 483 mm)
Weight		20.9 lbs. (9.5 kg)
Approvals		FCC, UL, C-UL, CE

Note: Specifications and design subject to change without notice.

Video/ Computer Cables & Adaptors

These accessories are supplied in order to connect the LCD Projector to Computer/ AV equipment. The numbers in the left column correspond with the numbers in the connection diagrams on pages 13-16.

No.	CABLE/ADAPTOR	PORT				LENGTH
		Projector side		Computer/AV products side		
1	VGA Cable (LSJA0133)	D-Sub M 15P (male)		D-Sub M 15P (male)		6.56 ft (2.0m)
2	VGA MAC13" Adaptor	D-sub M 15P (female)			MAC 15P (male)	—
3	VGA MAC16" Adaptor	D-sub M 15P (female)			MAC 15P (male)	—
4	PC Audio Cable	M3 stereo mini pin (male)		M3 stereo mini pin (male)		6.56 ft (2.0m)
5	Video RCA Cable	RCA pin (male)		RCA pin (male)		4.92 ft (1.5 m)
6	RCA-BNC pin Adaptor	RCA pin (male)			BNC pin (female)	—
7	Audio RCA Cable	RCA pin (male) X 2		RCA pin (male) X 2		4.92 ft (1.5 m)

Pin Assignment

Follow the instructions below when connecting to a computer.

A. Signal connector: 15-pin mini D-sub (PC/AT compatible model) Connect the signal cable to the 15-pin mini D-sub connector on the LCD Projector unit.

B. Signal connector: 15-pin D-sub (MAC)

To convert a MAC 15-pin D-sub connector to a 15-pin mini D-sub connector, use a VGA-MAC adaptor (included) and connect it to the 15-pin mini D-sub connector on the LCD Projector unit.

• MAC (13" or 16" Display, Separate Sync only)

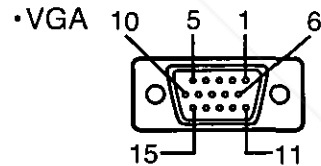
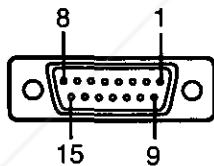

Pin No.	Signal	Pin No.	Signal
1	Ground for red video signal	1	Red video signal
2	Red video signal	2	Green video signal
3	Composite sync	3	Blue video signal
4	ID1	4	Unused
5	Green video signal	5	Unused (Through out)
6	Ground for green video signal	6	Ground for red video signal
7	Unused (ID2)	7	Ground for green video signal
8	Unused	8	Ground for blue video signal
9	Blue video signal	9	Unused
10	ID3	10	Ground
11	Ground	11	Unused
12	Vertical synchronizing signal	12	Unused
13	Ground for blue video signal	13	Horizontal synchronizing signal
14	Ground	14	Vertical synchronizing signal
15	Horizontal synchronizing signal	15	Unused

*1 - - - For 13" adaptor only

*2 - - - For 16" adaptor only

Note: When using a Composite Sync Output type Macintosh, please use a Composite Sync type VGA MAC Adaptor (pin 3 and pin 13 connected).

Connecting the LCD Projector

Connecting to audio/video output equipment (Video signal)

- Always turn off the Main Power Switch of the LCD Projector while connecting to video equipment, in order to protect both the LCD Projector and the equipment being connected.

1. PAL/SECAM/NTSC/PAL-M/PAL-N Video

(Diagram numbers correspond with numbers on page 12.)

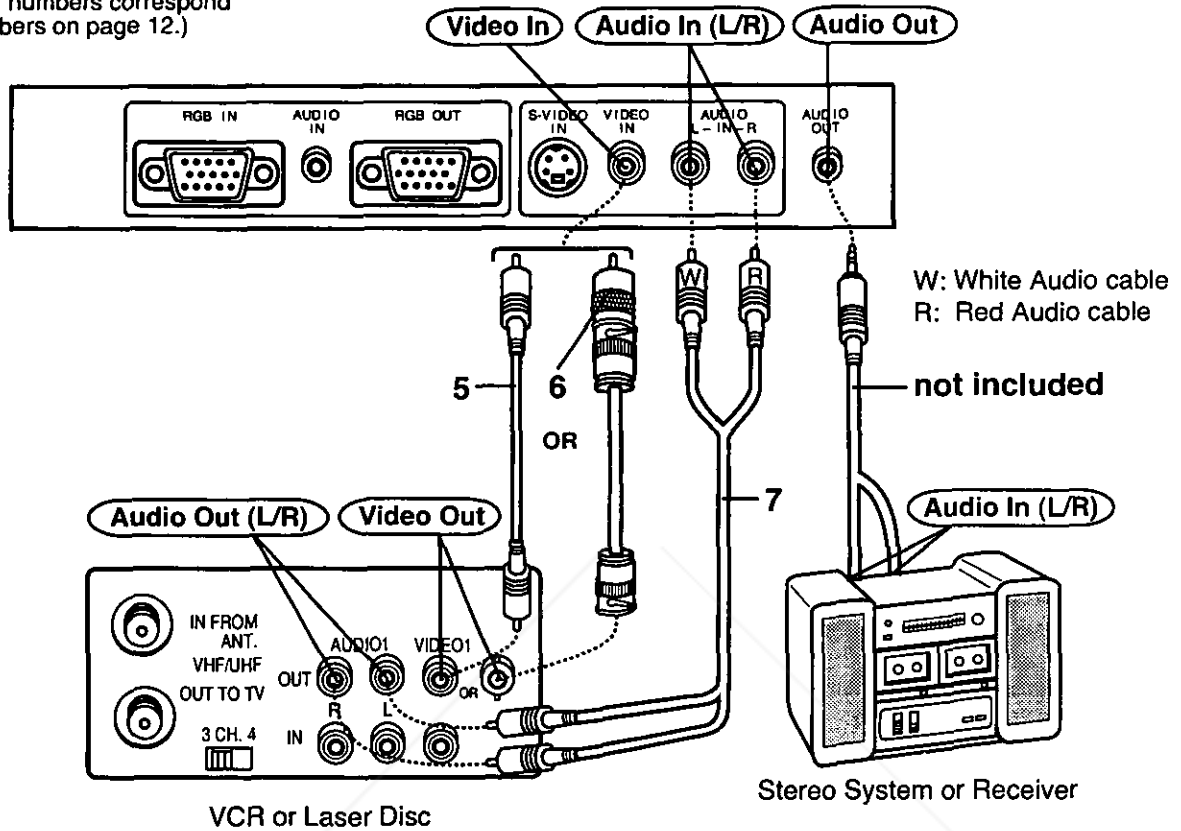

2. S-Video

(Diagram numbers correspond with numbers on page 12.)

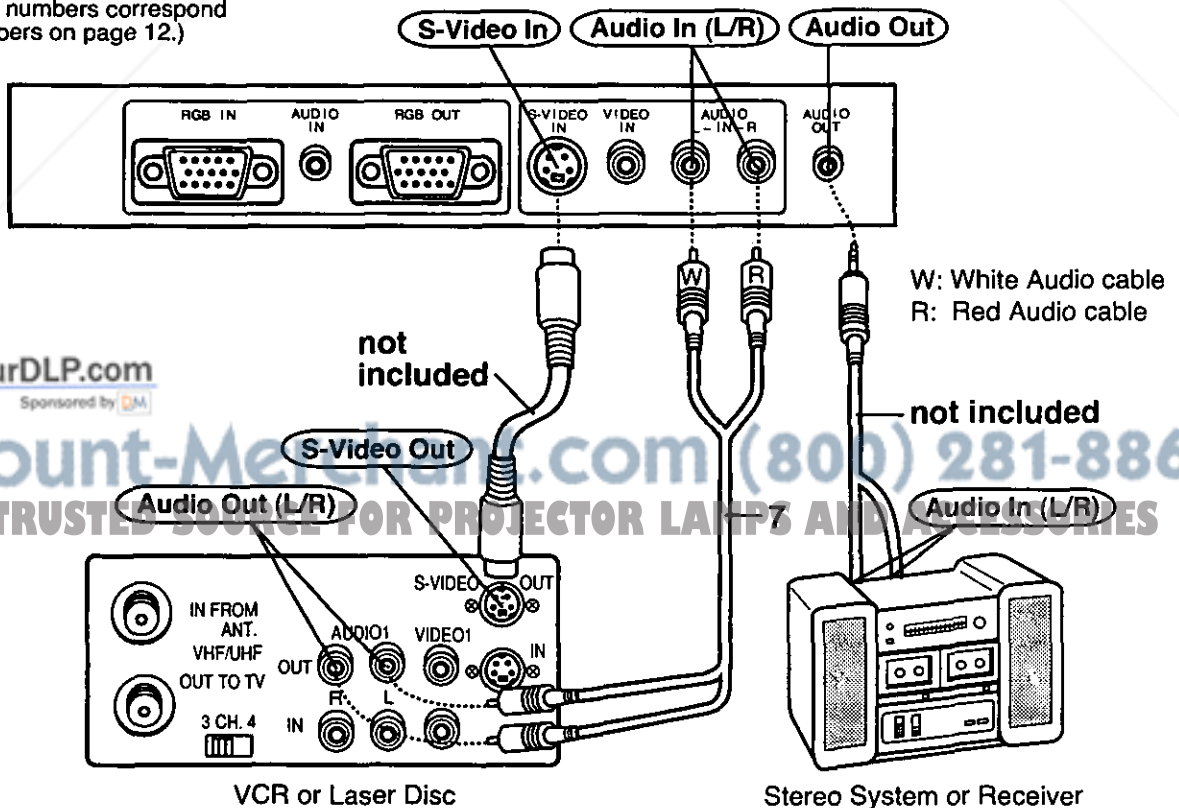

Connecting to a computer (RGB signal)

- Always turn off the Main Power Switch on the LCD Projector while connecting to computer equipment, in order to protect both the LCD Projector and the equipment being connected.
- The RGB input accepts signals from VGA, SVGA, XGA (Compression), and MAC compatible computers without the need for any additional hardware.
- Plug the VGA signal cable (supplied) correctly into the RGB IN terminal on the LCD Projector and into the RGB signal output terminal on the computer, and secure the plugs by tightening the thumb screws.
- Connect the MAC/VGA adaptor to the RGB-signal output or input terminal on your Macintosh Series computer. Then, firmly plug the VGA signal cable into both the RGB IN or RGB OUT terminal on the LCD projector and the MAC/VGA adaptor on the computer, and secure the plugs by tightening the thumb screws.
- To view images simultaneously on the monitor and projection screen, connect your computer monitor to the LCD Projector's RGB OUT terminal.
- When connecting the LCD Projector to a compatible computer other than a VGA, SVGA, XGA (Compression), or Macintosh series, a separate cable is needed.

1. PC (Desktop)

(Diagram numbers correspond with numbers on page 12.)

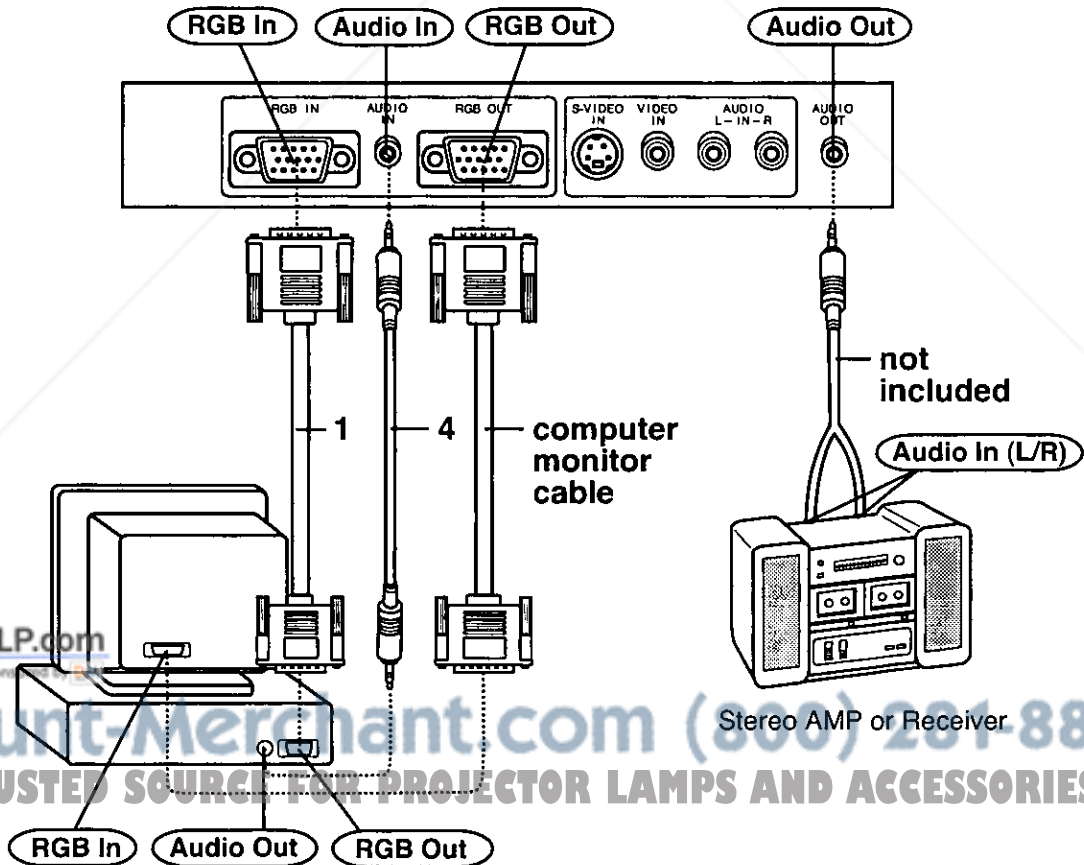

FixYourDLP.com
Discount-Merchant.com (800) 281-8860
THE TRUSTED SOURCE FOR PROJECTOR LAMPS AND ACCESSORIES

2. PC (Lap Top)

(Diagram numbers correspond with numbers on page 12.)

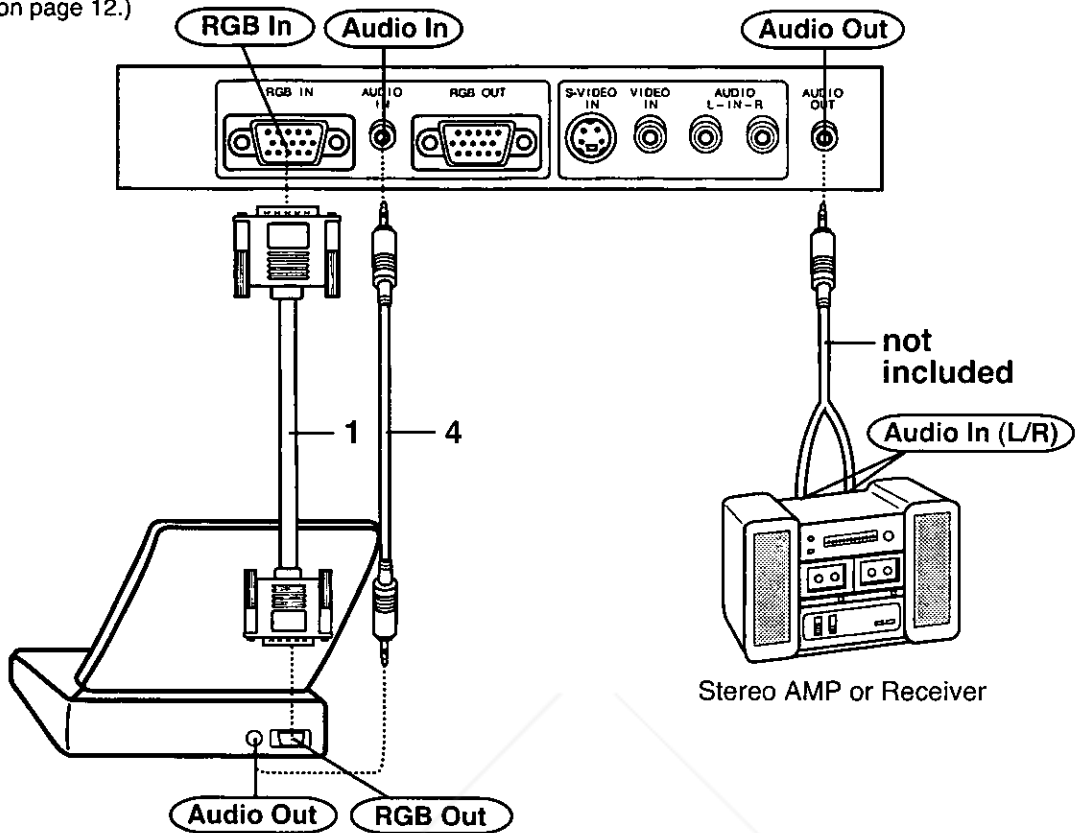

3. Macintosh (Desktop)

(Diagram numbers correspond with numbers on page 12.)

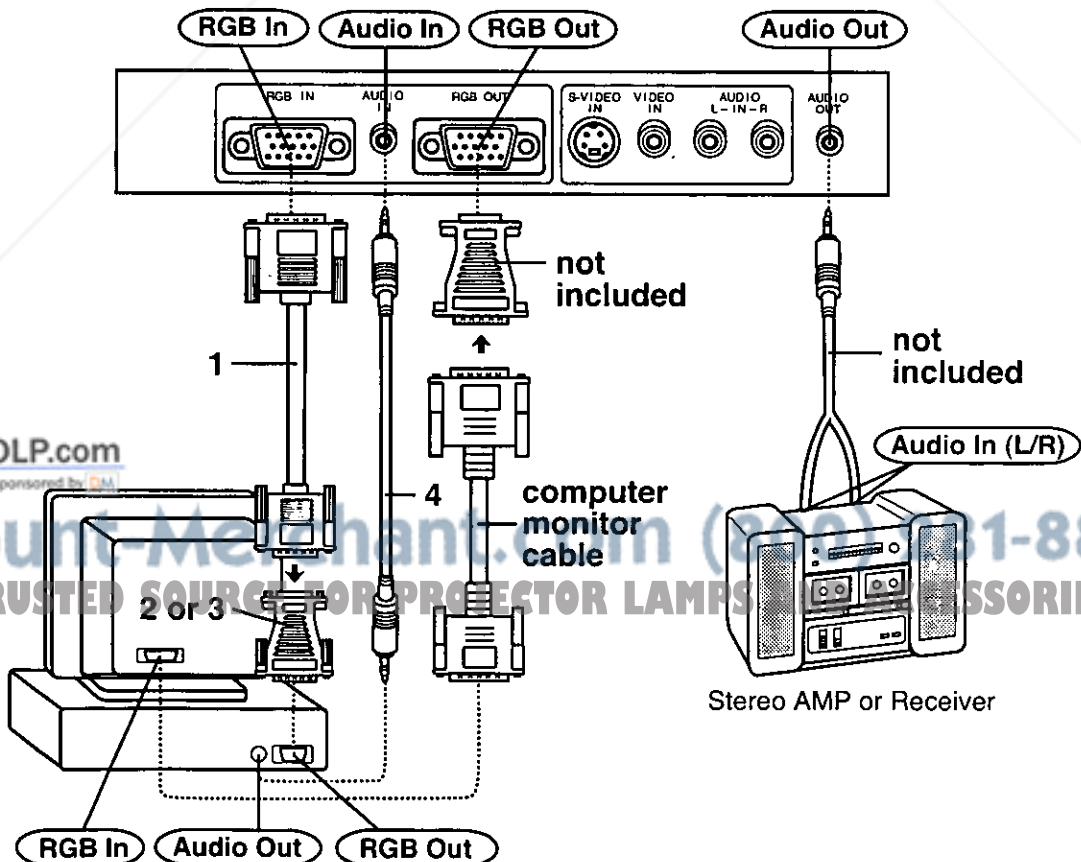

FixYourDLP.com
Sponsored by DM

Discount Merchant (800) 81-8860
THE TRUSTED SOURCE FOR PROJECTOR LAMPS & ACCESSORIES

4. Macintosh (Power Book)

(Diagram numbers correspond with numbers on page 12.)

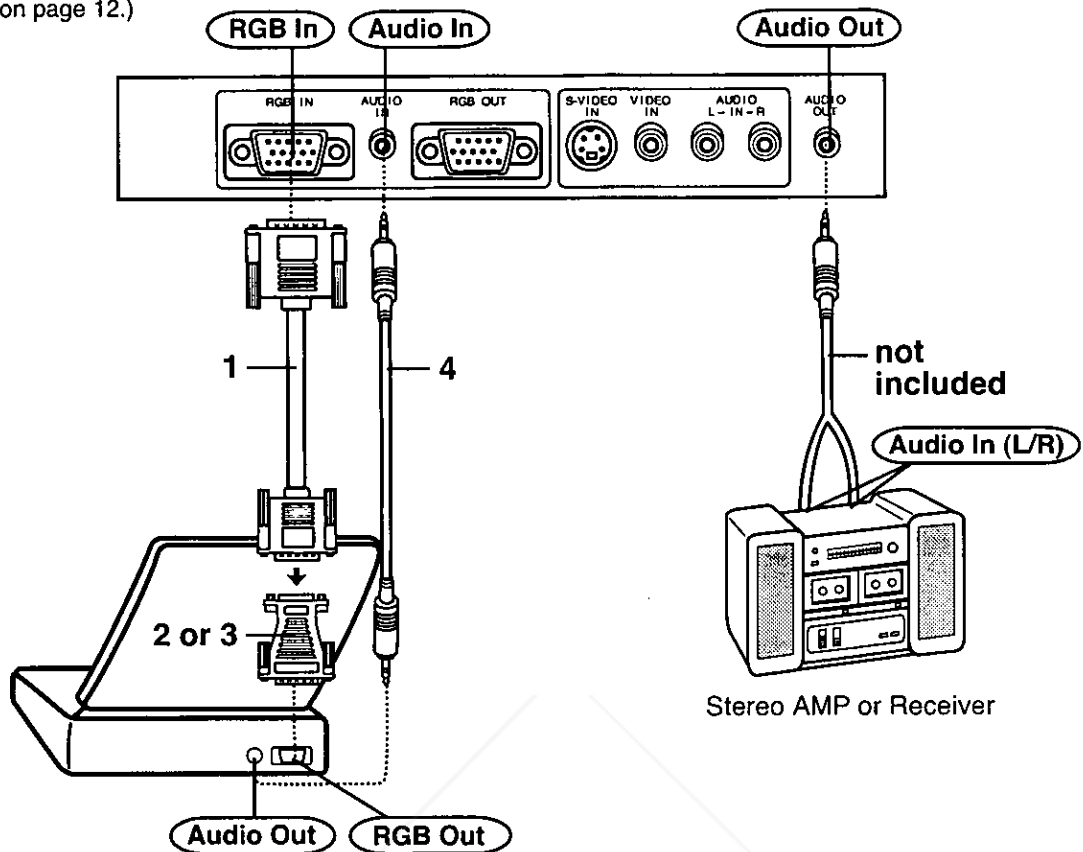

5. Macintosh (Power Mac)

(Diagram numbers correspond with numbers on page 12.)

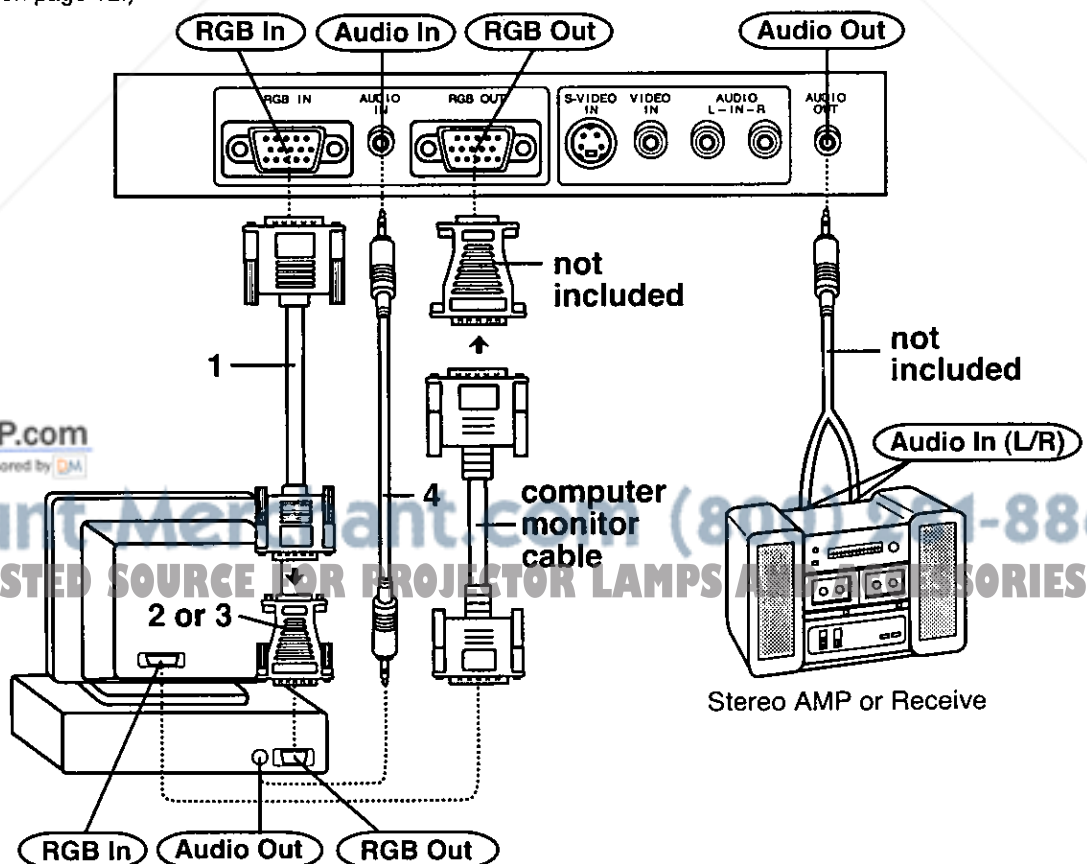

FixYourDLP.com
Sponsored by DM

Discount Merchants (800) 451-8860
THE TRUSTED SOURCE FOR PROJECTOR LAMPS AND ACCESSORIES

Basic LCD Projector Operation

Before you begin, make sure...

- All connections are made. (See pages 10 and 13 to 16.)
- LCD Projector is positioned properly. (See page 9.)
- LCD Projector is plugged in.
- Lens cap is removed.
- You have read Important Safeguards. (See pages 2, 3.)

1 Press the Main Power Switch ON.

The STAND BY(R) ON(G) indicator lights red on the top panel.

- The first time you turn on the power, or whenever the STAND BY(R) ON(G) indicator is not lit, press the Main Power Switch (ON/OFF) to turn on the power.

2 Press POWER on the LCD Projector or remote control ON.

When POWER is turned on, the red STAND BY(R) ON(G) indicator changes to green.

When POWER is turned off, the green STAND BY(R) ON(G) indicator changes to flashing red while the LCD Projector cools down and then to solid red when fan stops.

When the power is on, the STAND BY(R) ON(G) indicator indicates the operating condition of the lamp.

Red:	Main Power On (Lamp Off)
Green:	Lamp is ready
Flashing green:	Warming up
Flashing red:	Cooling Fan operating

See page 28, "Maintenance Indicators", for details.

3 Open control panel door and press INPUT, or press INPUT on the remote control to select the desired input mode.

Continue to press INPUT to set the desired input mode. Each press will change the display as shown below:

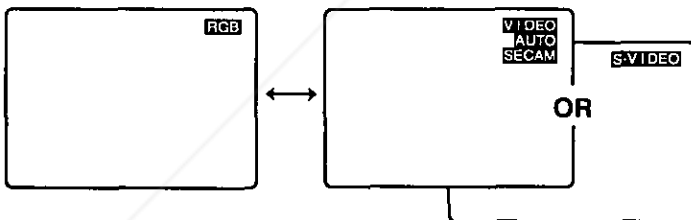

- If unit is connected with both VIDEO and S-VIDEO cables, the S-VIDEO mode has priority.

4 Turn on your computer (RGB) or start video playback (Video or S-Video).

- Adjust FOCUS and ZOOM Rings if necessary.

5 Press VOLUME +/- on the LCD Projector or remote control to adjust the volume level of the built-in speaker.

The number of segments (0 - 63) increases or decreases as the volume is adjusted.



6 Press POWER on the LCD Projector or remote control OFF.

- Do not turn off the Main Power Switch until the LCD Projector cooling fan has stopped and STAND BY(R) ON(G) indicator turns solid red.

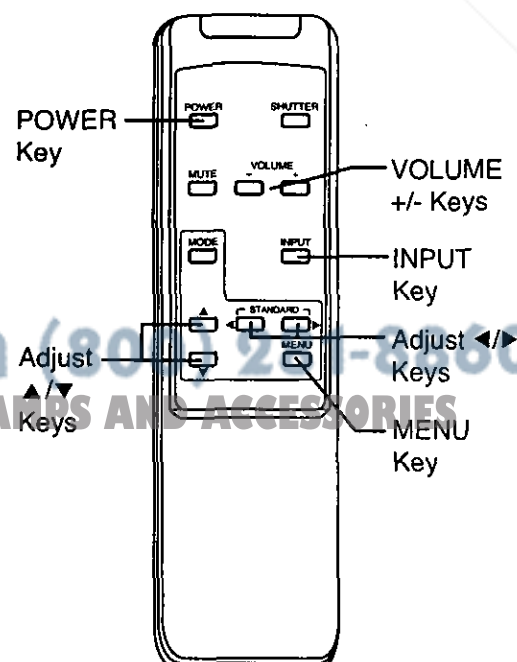
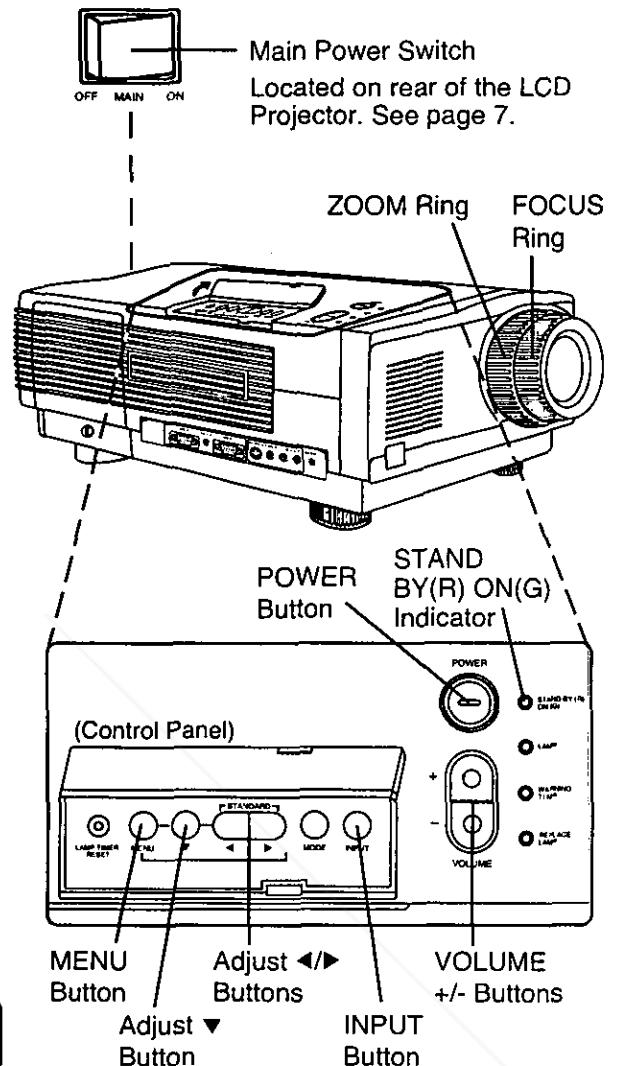

You may use keys on the remote control or buttons on the LCD Projector for the following operations.

● Selecting the Video System Format

The LCD Projector is equipped with full NTSC, PAL and SECAM video support. Usually set to AUTO, the broadcast format is automatically switched according to the tape inserted. If you experience poor color however, you may have to set to NTSC, PAL, or SECAM as described below. S-Video/ Video input is selected (page 17).

- 1 Press **MENU** to display the menu.
- 2 Press **▲** or **▼** to select **VIDEO SYSTEM**, and then **◀** or **▶** to display the screen.
- 3 Press **▲** or **▼** to select the desired video system.
- 4 Press **MENU** twice to exit.

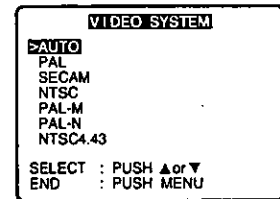
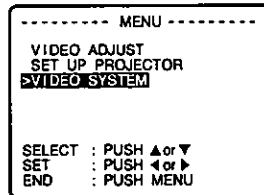

● Rear Screen Mode Projection

The image can be flipped to a mirror image of the input video signal for rear screen projection. See page 5 for illustration.

- 1 Press **MENU** to display the menu.
- 2 Press **▲** or **▼** to select **SET UP PROJECTOR**, and then **◀** or **▶** to display the screen.
- 3 Press **◀** or **▶** to select "ON" or "OFF".
 - Select OFF to return to the standard projection format.
 - Select ON to flip to a mirror image of the input signal.
- 4 Press **MENU** twice to exit.

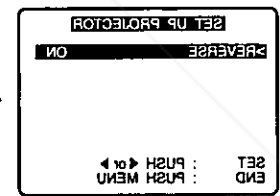
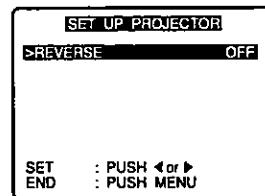
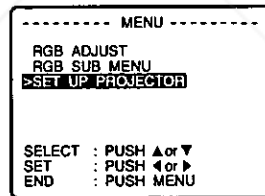

Projected Image Adjustment

This LCD projector's picture is set to standard specifications at the factory. However, you can adjust the image to suit your own preferences by using the VIDEO or RGB ADJUST feature. Three memory modes allow you to adjust and save up to three sets of settings for each input signal (S-VIDEO/ VIDEO and RGB). For video signal input, five items can be adjusted: "COLOR", "TINT", "BRIGHTNESS", "PICTURE", and "SHARPNESS". For RGB signal input, six items can be adjusted: "BRIGHTNESS", "PICTURE", "V POSI", "H POSI", "H SIZE", and "PHASE".

Video Input Image Adjustment

S-VIDEO or VIDEO input is selected (page 17).
Use buttons on the remote control or LCD Projector.

1 Press MENU to display the menu.

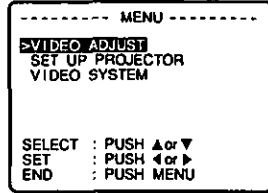

2 Press ▲ or ▼ to select VIDEO ADJUST, and ◀ or ▶ to display the screen.

- 3 different sets of control adjustments can be memorized for different projection situations.

3 Press MODE repeatedly to choose one of the three memory modes for adjustment (page 22).

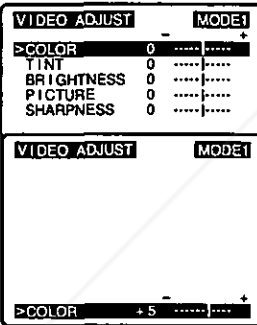

4 Press ▲ or ▼ to select, and ◀ or ▶ to display the item to be adjusted.

5 Press ◀ or ▶ to adjust as described below.

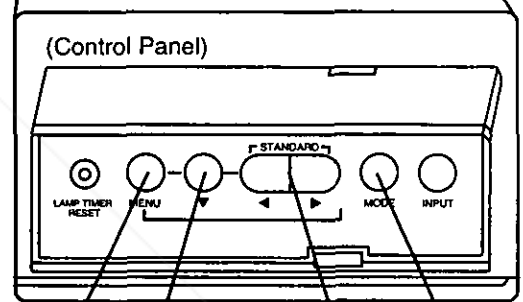
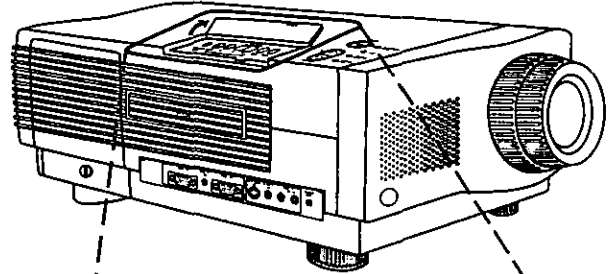

MENU Button Adjust ▼ Buttons Adjust ◀/▶ Buttons MODE Button

Adjustments For S-Video/ Video Input

COLOR Control (Adjust color intensity level.)

- Press ▶ to deepen the color.
- Press ◀ to make the color paler.

TINT Control (Adjust hue for realistic tones.)

- Press ▶ for more green.
- Press ◀ for more purple.
- Tint will not adjust when LCD Projector is set to PAL, or SECAM video formats.

BRIGHTNESS Control

- (Adjust black level to room brightness.)
- Press ▶ to brighten the image.
- Press ◀ to darken the background.

PICTURE Control (Adjust overall picture intensity.)

- Press ▶ for a stronger picture.
- Press ◀ for a fainter picture.

SHARPNESS Control (Adjust picture sharpness.)

- Press ▶ to sharpen the edges of the image.
- Press ◀ to soften the edges of the image.

Recall Standard Settings

- Press ◀ and ▶ together. If the menu showing all items is displayed, all items will be reset. If a single item is displayed, only that item will be reset.

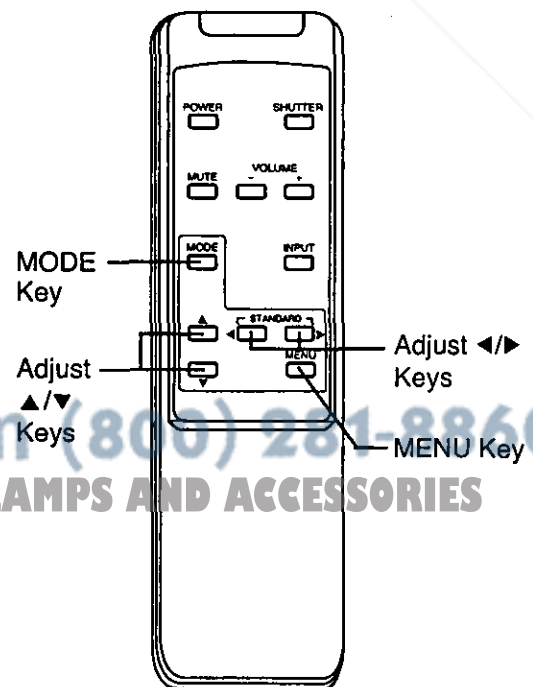

6 Press MENU once to display the video adjust menu, **or twice** to exit.

RGB Input Image Adjustment

RGB input is selected (page 17).
 Use buttons on the remote control or LCD Projector.
 For V POSI, H POSI, and H SIZE adjustments, see the
 PC output timing relative value chart on page 21.

- 1 Press MENU** to display the menu.
- 2 Press ▲ or ▼** to select RGB ADJUST, and **◀ or ▶** to display the screen.
 - 3 different sets of control adjustments can be memorized to accommodate for different projection situations.
- 3 Press MODE repeatedly** to choose one of the three memory modes for adjustment (page 22).
- 4 Press ▲ or ▼** to select, and **◀ or ▶** to display the item to be adjusted.
- 5 Press ▶ or ◀** to adjust as described below.

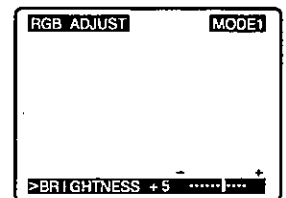
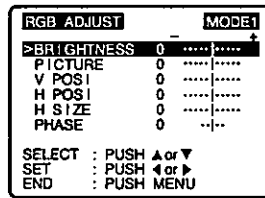
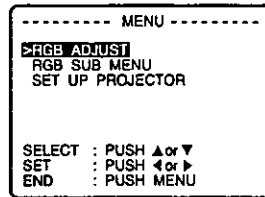

Adjustments For RGB Input

BRIGHTNESS Control

(Adjust black level to room brightness.)

- Press ▶ to brighten the image.
- Press ◀ to darken the background.

PICTURE Control

(Adjust overall picture intensity.)

- Press ▶ for a stronger picture.
- Press ◀ for a fainter picture.

V POSI (Vertical Position) Control

(Adjust vertical position within projected screen.)

- Press ◀ to move down or ▶ to move up.

H POSI (Horizontal Position) Control

(Adjust horizontal position within projected screen.)

- Press ◀ to move left or ▶ to move right.

H (Horizontal) SIZE Control

(Adjust data display, timing, and attain the correct horizontal image size.)

- Press ◀ or ▶ until screen is free of black lines.
- Use test pattern shown at right.

PHASE Control

(Adjust vertical line strength so that text is readable.)

- Press ◀ or ▶ so that the white horizontal lines are clear and distinct. Use test pattern shown at right.

Recall Standard Settings

(only BRIGHTNESS and PICTURE)

- Press ◀ and ▶ together. If the menu showing all items is displayed, BRIGHTNESS and PICTURE will be reset. If a single item is displayed, only that item will be reset.

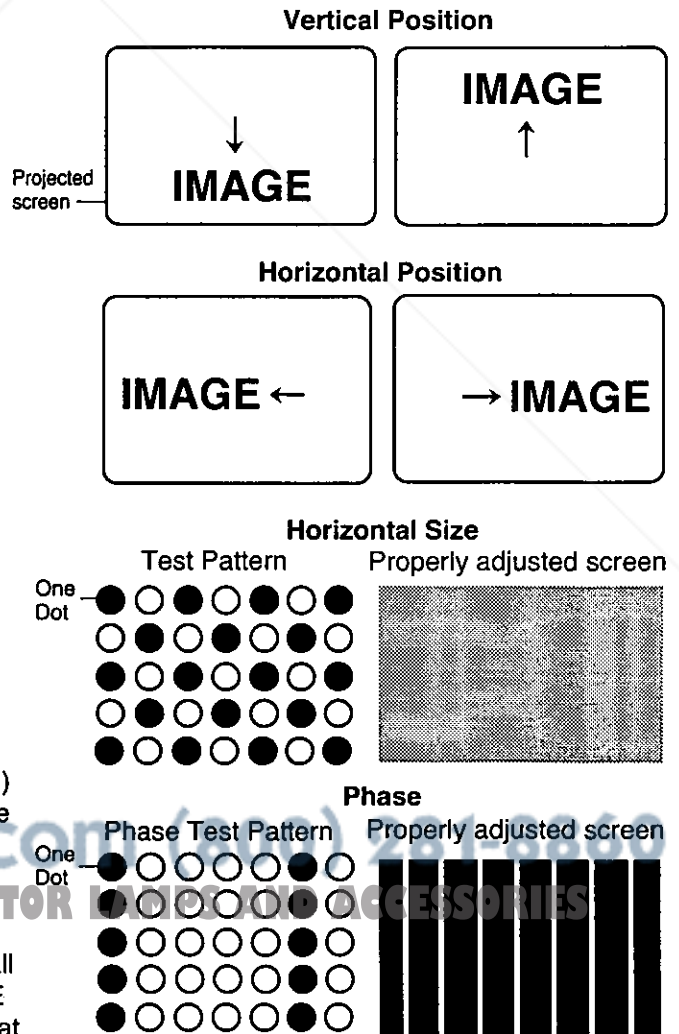

- 6 Press MENU once** to redisplay the RGB ADJUST menu, **or twice** to exit

PC Output Timing Relative Value Chart

Model	Vertical Position	Horizontal Position	Horizontal size
IBM 640 X 350 at 70 Hz/ IBM 640 X 400 at 70 Hz	-25 – +25	-28 – +26	-50 – +90
IBM 640 X 480 at 60 Hz	-25 – +25	-28 – +26	-50 – +90
MAC II 640 X 480	-25 – +25	-28 – +28	-50 – +90
MAC 16" 832 X 624	-25 – +25	-28 – +28	-50 – +90
VESA 640 X 350 at 85 Hz/ VESA 640 X 400 at 85 Hz	-25 – +25	-28 – +28	-50 – +90
VESA 640 X 480 at 72 Hz	-22 – +25	-28 – +28	-50 – +90
VESA 640 X 480 at 75 Hz	-10 – +25	-28 – +28	-50 – +90
VESA 640 X 480 at 85 Hz	-20 – +25	-28 – +28	-50 – +90
VESA 800 X 600 at 56 Hz	-15 – +25	-28 – +28	-50 – +90
VESA 800 X 600 at 60 Hz	-17 – +25	-28 – +28	-50 – +90
VESA 800 X 600 at 72 Hz	-19 – +25	-28 – +19	-50 – +90
VESA 800 X 600 at 75 Hz	-14 – +25	-28 – +28	-50 – +90
VESA 800 X 600 at 85 Hz	-20 – +25	-28 – +28	-50 – +90
VESA 1024 X 768 at 60 Hz	-20 – +25	-28 – +28	-50 – +90
VESA 1024 X 768 at 70 Hz	-20 – +25	-28 – +28	-50 – +90



Discount-Merchant.com (800) 281-8860
THE TRUSTED SOURCE FOR PROJECTOR LAMPS AND ACCESSORIES

Adjusting the RGB Input Levels

RGB input levels are preset at the factory and in most cases will not need adjustment. However, depending on the connected computer, the levels may need adjustment. Up to 3 sets of parameters can be memorized for RGB input.

1 Press MENU to display the menu.

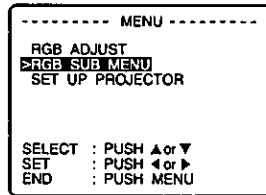

2 Press ▲ or ▼ to select RGB SUB MENU, and then **◀ or ▶** to display the screen.

- 3 different sets of control adjustments can be memorized to accommodate for different projection situations.

3 Press MODE repeatedly to choose one of the three memory modes for adjustment.

4 Press ▲ or ▼ to select, and **◀ or ▶** to display the item to be adjusted.

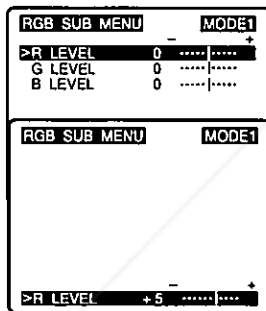

5 Press ◀ or ▶ to adjust the value level.

Recall Standard Settings

Press **◀** and **▶** together. If the menu showing all items is displayed, all items will be reset. If a single item is displayed, only that item will be reset.

- Factory setting is "0" for each R, G and B level.

6 Press MENU once to return to the RGB input level menu **or twice** to exit.

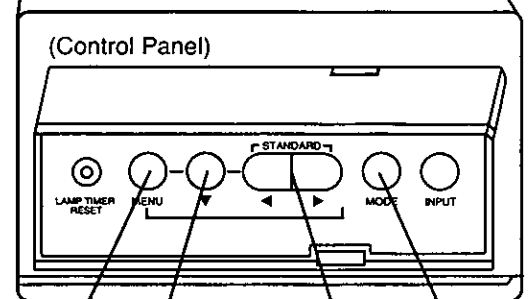
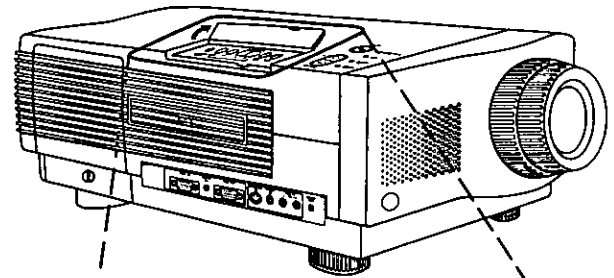

MENU Button Adjust ▼ Button Adjust ◀/▶ Buttons MODE Button

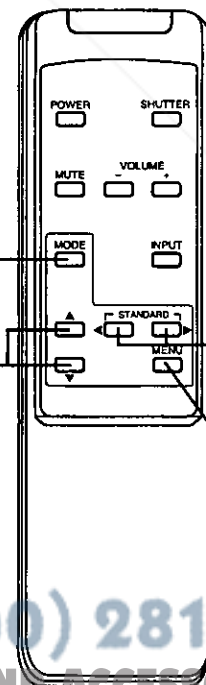

MODE Key Adjust ▲/▼ Keys Adjust ◀/▶ Keys MENU Key

Selecting the Picture Memory

Press MODE on the remote control or LCD Projector to select the desired picture mode.

When MODE is pressed, the preset settings will first be displayed on the screen for about 5 seconds.

- Each time you press MODE, the display will change as shown below:



Timing Specifications

Separate Sync.

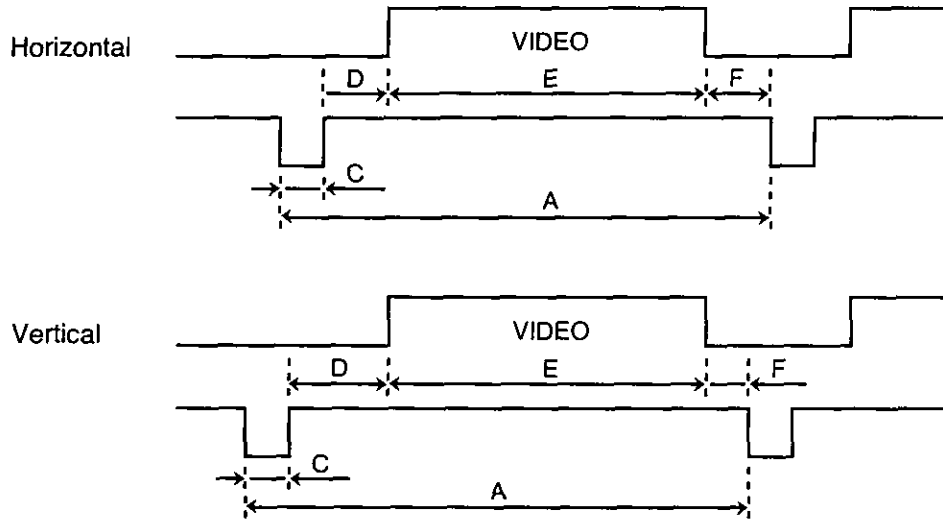

H/V Composite Sync.

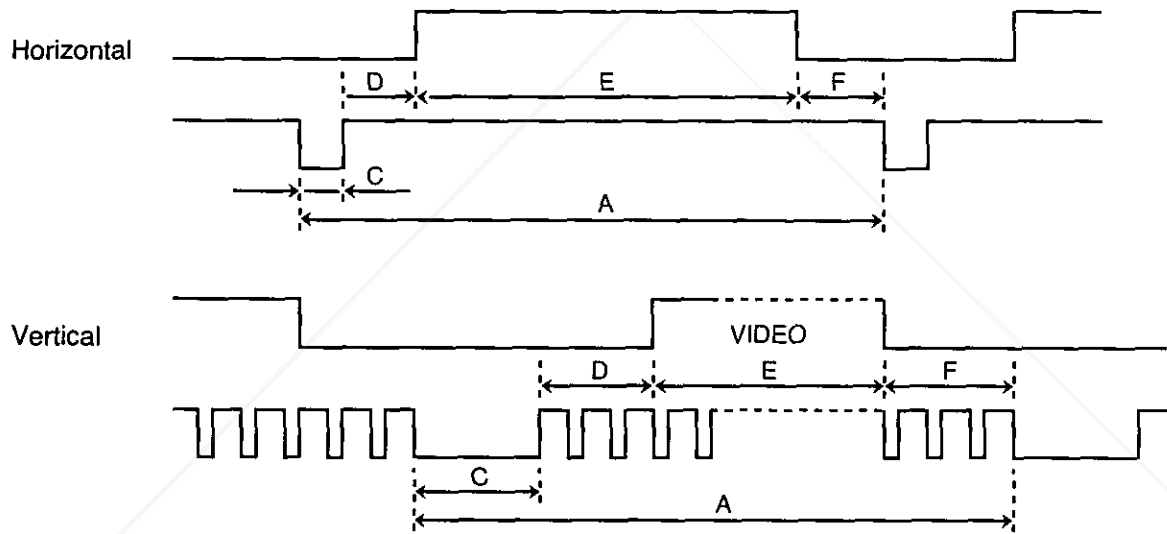

Sync. on Green

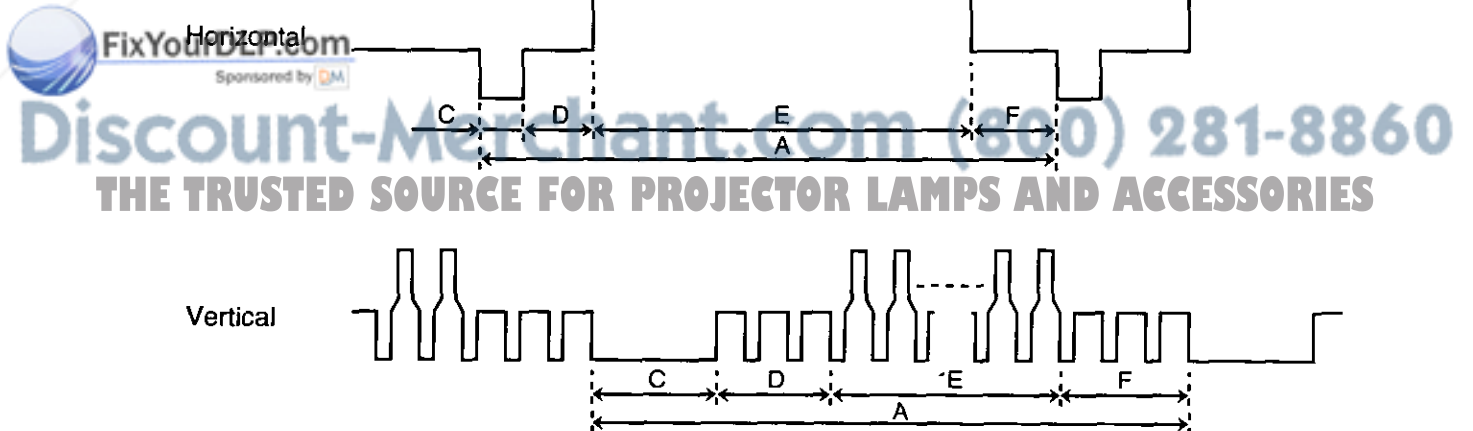

Factory Preset Timing

		Preset timing		
		IBM 640 X 350 at 70 Hz	IBM 640 X 400 at 70 Hz	IBM 640 X 480 at 60 Hz
DOT CLOCK		25.1745 MHz	25.1745 MHz	25.1745 MHz
H O R I Z	fH	31.4681 KHz	31.4681 KHz	31.4681 KHz
	A - PERIOD	31.778 μ s (800 dots)	31.778 μ s (800 dots)	31.778 μ s (800 dots)
	B - BLANKING	6.356 μ s (160 dots)	6.356 μ s (160 dots)	6.356 μ s (160 dots)
	C - SYNC WIDTH	3.813 μ s (96 dots)	3.813 μ s (96 dots)	3.813 μ s (96 dots)
	D - BACK PORCH	1.907 μ s (48 dots)	1.907 μ s (48 dots)	1.907 μ s (48 dots)
	E - ACTIVE TIME	25.423 μ s (640 dots)	25.423 μ s (640 dots)	25.423 μ s (640 dots)
	F - FRONT PORCH	0.636 μ s (16 dots)	0.636 μ s (16 dots)	0.636 μ s (16 dots)
V E R T	fV	70.0849 Hz	70.0849 Hz	59.939 Hz
	A - PERIOD	14.268 ms (449 lines)	14.268 ms (449 lines)	16.684 ms (525 lines)
	B - BLANKING	3.146 ms (99 lines)	1.557 ms (49 lines)	1.430 ms (45 lines)
	C - SYNC WIDTH	0.064 ms (2 lines)	0.064 ms (2 lines)	0.064 ms (2 lines)
	D - BACK PORCH	1.907 ms (60 lines)	1.112 ms (35 lines)	1.049 ms (33 lines)
	E - ACTIVE TIME	11.122 ms (350 lines)	12.711 ms (400 lines)	15.254 ms (480 lines)
	F - FRONT PORCH	1.176 ms (37 lines)	0.381 ms (12 lines)	0.318 ms (10 lines)
SYNC POLARITY (H/V)		Positive / Negative	Negative / Positive	Negative / Negative

		Reservation timing	Preset timing	
		MAC LC 640 X 480	MAC II 640 X 480	MAC 16" 832 X 624
DOT CLOCK		31.334 MHz	30.2410 MHz	57.283 MHz
H O R I Z	fH	34.97 KHz	35.0012 KHz	49.725 KHz
	A - PERIOD	28.598 μ s (896 dots)	28.570 μ s (864 dots)	20.111 μ s (1152 dots)
	B - BLANKING	8.171 μ s (256 dots)	7.407 μ s (224 dots)	5.587 μ s (320 dots)
	C - SYNC WIDTH	2.043 μ s (64 dots)	2.803 μ s (63 dots)	1.117 μ s (64 dots)
	D - BACK PORCH	2.426 μ s (76 dots)	3.241 μ s (98 dots)	3.910 μ s (224 dots)
	E - ACTIVE TIME	20.425 μ s (640 dots)	21.163 μ s (640 dots)	14.524 μ s (832 dots)
	F - FRONT PORCH	3.702 μ s (116 dots)	2.083 μ s (63 dots)	0.559 μ s (32 dots)
V E R T	fV	66.61 Hz	66.6689 Hz	74.550 Hz
	A - PERIOD	15.013 ms (525 lines)	15.000 ms (525 lines)	13.414 ms (667 lines)
	B - BLANKING	1.287 ms (45 lines)	1.286 ms (45 lines)	0.865 ms (43 lines)
	C - SYNC WIDTH	0.086 ms (3 lines)	0.086 ms (3 lines)	0.060 ms (3 lines)
	D - BACK PORCH	1.115 ms (39 lines)	1.114 ms (39 lines)	0.784 ms (39 lines)
	E - ACTIVE TIME	13.726 ms (480 lines)	13.714 ms (480 lines)	12.549 ms (624 lines)
	F - FRONT PORCH	0.886 ms (3 lines)	0.086 ms (3 lines)	0.020 ms (1 line)
SYNC POLARITY (H/V)		Negative / Negative	Sync on Green or Composit	Negative / Negative

		Preset timing		
		VESA 640 X 350 at 85 Hz	VESA 640 X 400 at 85 Hz	VESA 640 X 480 at 72 Hz
DOT CLOCK		31.5 MHz	31.5 MHz	31.5 MHz
H O R I Z	fH	37.861 KHz	37.861 KHz	37.861 KHz
	A - PERIOD	26.413 μ s (832 dots)	26.413 μ s (832 dots)	26.413 μ s (832 dots)
	B - BLANKING	6.095 μ s (192 dots)	6.095 μ s (192 dots)	6.095 μ s (192 dots)
	C - SYNC WIDTH	2.032 μ s (64 dots)	2.032 μ s (64 dots)	1.270 μ s (40 dots)
	D - BACK PORCH	3.048 μ s (96 dots)	3.048 μ s (96 dots)	4.063 μ s (128 dots)
	E - ACTIVE TIME	20.317 μ s (640 dots)	20.317 μ s (640 dots)	20.317 μ s (640 dots)
	F - FRONT PORCH	1.016 μ s (32 dots)	1.016 μ s (32 dots)	0.762 μ s (24 dots)
V E R T	fV	85.080 Hz	85.080 Hz	72.8088 Hz
	A - PERIOD	11.754 ms (445 lines)	11.754 ms (445 lines)	13.735 ms (520 lines)
	B - BLANKING	2.509 ms (95 lines)	1.189 ms (45 lines)	1.057 ms (40 lines)
	C - SYNC WIDTH	0.079 ms (3 lines)	0.079 ms (3 lines)	0.079 ms (3 lines)
	D - BACK PORCH	1.585 ms (60 lines)	1.083 ms (41 lines)	0.740 ms (28 lines)
	E - ACTIVE TIME	9.244 ms (350 lines)	10.565 ms (400 lines)	12.678 ms (480 lines)
	F - FRONT PORCH	0.845 ms (32 lines)	0.026 ms (1 line)	0.238 ms (9 lines)
SYNC POLARITY (H/V)		Positive / Negative	Negative / Positive	Negative / Negative

		Preset timing		
		VESA 640 X 480 at 75 Hz	VESA 640 X 480 at 85Hz	VESA 800 X 600 at 56Hz
DOT CLOCK		31.5 MHz	36.000 MHz	36.000 MHz
H O R I Z	f H	37.500 KHz	43.269 KHz	35.156 KHz
	A - PERIOD	26.667 μ s (840 dots)	23.111 μ s (832 dots)	28.444 μ s (1024 dots)
	B - BLANKING	6.349 μ s (200 dots)	5.333 μ s (192 dots)	6.222 μ s (224 dots)
	C - SYNC WIDTH	2.032 μ s (64 dots)	1.333 μ s (48 dots)	2.000 μ s (72 dots)
	D - BACK PORCH	3.810 μ s (120 dots)	3.111 μ s (112 dots)	3.556 μ s (128 dots)
	E - ACTIVE TIME	20.317 μ s (640 dots)	17.778 μ s (640 dots)	22.222 μ s (800 dots)
V E R T	F - FRONT PORCH	0.508 μ s (16 dots)	0.889 μ s (32 dots)	0.667 μ s (24 dots)
	f V	75.0000 Hz	85.008 Hz	56.250 Hz
	A - PERIOD	13.333 ms (500 lines)	11.764 ms (509 lines)	17.778 ms (625 lines)
	B - BLANKING	0.533 ms (20 lines)	0.670 ms (29 lines)	0.711 ms (25 lines)
	C - SYNC WIDTH	0.080 ms (3 lines)	0.069 ms (3 lines)	0.057 ms (2 lines)
	D - BACK PORCH	0.427 ms (16 lines)	0.578 ms (25 lines)	0.626 ms (22 lines)
V E R T	E - ACTIVE TIME	12.800 ms (480 lines)	11.093 ms (480 lines)	17.067 ms (600 lines)
	F - FRONT PORCH	0.027 ms (1 line)	0.023 ms (1 line)	0.028 ms (1 line)
SYNC POLARITY (H/V)		Negative / Negative	Negative / Negative	Positive / Positive

		Preset timing		
		VESA 800 X 600 at 60Hz	VESA 800 X 600 at 72Hz	VESA 800 X 600 at 75Hz
DOT CLOCK		40.000 MHz	50.000 MHz	49.500 MHz
H O R I Z	f H	37.879 KHz	48.077 KHz	46.875 KHz
	A - PERIOD	26.400 μ s (1056 dots)	20.800 μ s (1040 dots)	21.333 μ s (1056 dots)
	B - BLANKING	6.400 μ s (256 dots)	4.800 μ s (240 dots)	5.172 μ s (256 dots)
	C - SYNC WIDTH	3.200 μ s (128 dots)	2.400 μ s (120 dots)	1.616 μ s (80 dots)
	D - BACK PORCH	2.200 μ s (88 dots)	1.280 μ s (64 dots)	3.232 μ s (160 dots)
	E - ACTIVE TIME	20.000 μ s (800 dots)	16.000 μ s (800 dots)	16.162 μ s (800 dots)
V E R T	F - FRONT PORCH	1.000 μ s (40 dots)	1.120 μ s (56 dots)	0.323 μ s (16 dots)
	f V	60.317 Hz	72.188 Hz	75.000 Hz
	A - PERIOD	16.579 ms (628 lines)	13.853 ms (666 lines)	13.333 ms (625 lines)
	B - BLANKING	0.739 ms (28 lines)	1.373 ms (66 lines)	0.533 ms (25 lines)
	C - SYNC WIDTH	0.106 ms (4 lines)	0.125 ms (6 lines)	0.064 ms (3 lines)
	D - BACK PORCH	0.607 ms (23 lines)	0.478 ms (23 lines)	0.448 ms (21 lines)
V E R T	E - ACTIVE TIME	15.840 ms (600 lines)	12.480 ms (600 lines)	12.800 ms (600 lines)
	F - FRONT PORCH	0.026 ms (1 line)	0.770 ms (37 lines)	0.021 ms (1 line)
SYNC POLARITY (H/V)		Positive / Positive	Positive / Positive	Positive / Positive

		Preset timing	Preset timing (* Compression)	
		VESA 800 X 600 at 85Hz	VESA 1024 X 768 at 60Hz	VESA 1024 X 768 at 70Hz
DOT CLOCK		56.250 MHz	65.000 MHz	75.000 MHz
H O R I Z	f H	53.674 KHz	48.363 KHz	56.476 KHz
	A - PERIOD	18.631 μ s (1048 dots)	20.677 μ s (1344 dots)	17.707 μ s (1328 dots)
	B - BLANKING	4.409 μ s (248 dots)	4.923 μ s (320 dots)	4.054 μ s (304 dots)
	C - SYNC WIDTH	1.138 μ s (64 dots)	2.092 μ s (136 dots)	1.813 μ s (136 dots)
	D - BACK PORCH	2.702 μ s (152 dots)	2.462 μ s (160 dots)	1.920 μ s (144 dots)
	E - ACTIVE TIME	14.222 μ s (800 dots)	15.754 μ s (1024 dots)	13.653 μ s (1024 dots)
V E R T	F - FRONT PORCH	0.569 μ s (32 dots)	0.369 μ s (24 dots)	0.320 μ s (24 dots)
	f V	85.061 Hz	60.004 Hz	70.069 Hz
	A - PERIOD	11.756 ms (631 lines)	16.666 ms (806 lines)	14.272 ms (806 lines)
	B - BLANKING	0.578 ms (31 lines)	0.786 ms (38 lines)	0.673 ms (38 lines)
	C - SYNC WIDTH	0.056 ms (3 lines)	0.124 ms (6 lines)	0.106 ms (6 lines)
	D - BACK PORCH	0.503 ms (27 lines)	0.600 ms (29 lines)	0.513 ms (29 lines)
V E R T	E - ACTIVE TIME	11.179 ms (600 lines)	15.880 ms (768 lines)	13.599 ms (768 lines)
	F - FRONT PORCH	0.019 ms (1 line)	0.062 ms (3 lines)	0.053 ms (3 lines)
SYNC POLARITY (H/V)		Positive / Positive	Positive / Positive	Positive / Positive

*Note: Because some lines are omitted, picture degradation may occur.

Maintenance

Air Filter

The air filter should be cleaned about every 100 hours. Also, clean the air filter if the WARNING TEMP indicator lights up. Clean the filter more often when the projector is used in a dusty or smoky location. Replace the filter when it is clogged or dirty even after cleaning. Order new filter part number ET-AF201.

Cleaning the Filter

Tools required: Vacuum Cleaner.

- Wait until the cooling fan stops and the STAND BY(R) ON(G) indicator turns off.

1 Set the Main Power Switch to OFF and unplug the power cord.

2 Remove the Filter Holder.

Place the Projector on its side with the handle facing up. Grasp the filter holder by the depressed portion and slide it out to remove.

3 Remove the Filter.

Hold the filter holder and lift up on the long tab to remove the filter from the filter holder.

4 Clean the Filter.

Firmly grasp the Air Filter as shown. Gently remove any accumulated dust from both sides of the Air Filter with your vacuum cleaner. (Set vacuum to "LOW".)

CAUTION: Operating LCD Projector with torn or damaged Filter may cause damage to LCD Projector.

5 Replace the Filter.

Replace the air filter so that all the locking tabs snap into place in the filter holder.

6 Replace the Filter Holder.

Line up the filter so that the guide tabs of the LCD Projector fit into the grooves in the sides of the Filter Holder and slide it back into place.

Note:

- The LCD Projector power cannot be turned on unless the filter holder is correctly installed.

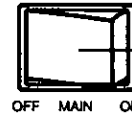
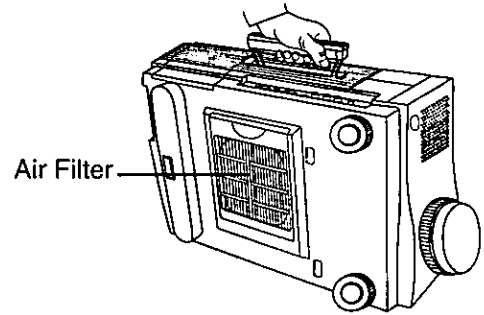

Main Power Switch
Located on rear of the LCD Projector. See page 7.

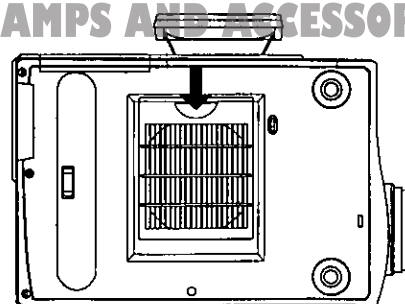
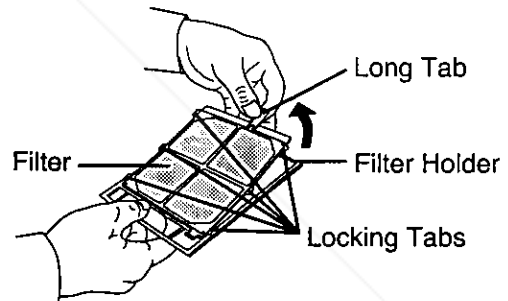
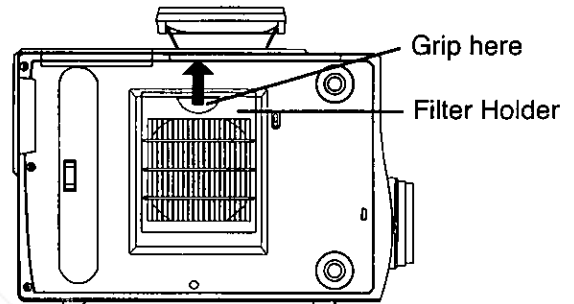

Lamp

The LCD Projector lamp has a limited operating life of approximately 1100 hours. "LAMP TIME REMAINING 100h" will be displayed on-screen when operation time reaches 1000 hours. Then, each time the power is turned on, the Lamp life remaining will be displayed.

- A 10 second warning display (20 seconds when the LCD Projector power is turned on) will appear every 10 hours from 1000 hours of operation until 1090 hours. The warning will then be displayed every hour from 1090 hours of operation time. The warning display will flash from 1100 hours and continue to be displayed in negative digits.

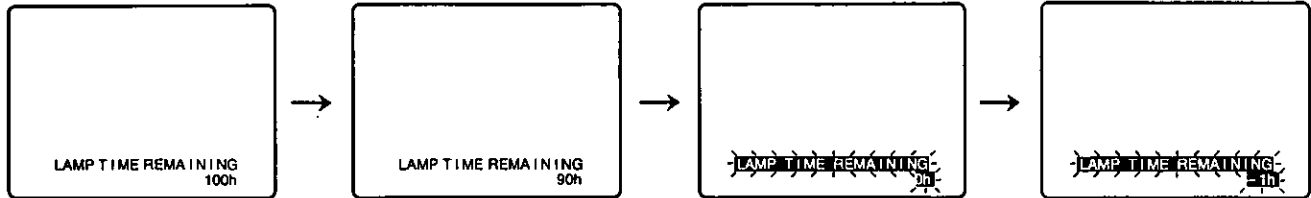

Lamp Replacement

Order Lamp ET-LA201.
Tools required: A coin.

- 1** After the cooling fan has stopped, and **STAND BY(R) ON(G)** indicator turns solid red. Set the Main Power Switch to OFF. Then, unplug the LCD Projector by removing Power cord from LCD Projector AC socket.

- 2** First read caution and warning labels on Lamp cover. Then, remove the Lamp cover screw (1) by using coin, and take off the lamp cover.

- 3** Caution, be very careful. Lamp housing may still be hot to touch. Remove the lamp unit screw (1), then grasp the Lamp unit handle and carefully pull it from the LCD Projector. Keep Lamp housing opening to your right. Do not touch Lamp or point Lamp opening at anyone.

WARNING: The lamp may be hot. Be careful when handling.

CAUTION: High-pressure lamp may be explode if improperly handled.

- 4** Carefully remove Lamp ET-LA201 from the LCD Projector now. Do not touch Lamp or point Lamp opening at anyone. Do not drop, impact of dropping may cause Lamp to explode. Install a new lamp unit (ET-LA201) available from your Panasonic Service Center.

Replace the Lamp unit screw and the Lamp cover screw using a coin to tighten.

- 6** Plug the LCD Projector back in by inserting Power cord in LCD Projector AC socket and set the Main Power Switch to ON.

- 7** Press the LAMP TIMER RESET button by using a ball point pen. Do not reset unless Lamp is replaced. The Lamp Replacement indicator goes out.

- 8** Properly dispose of old Lamp.

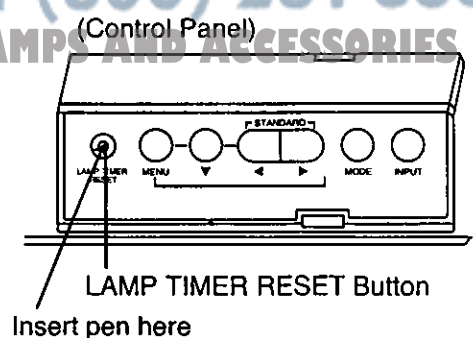
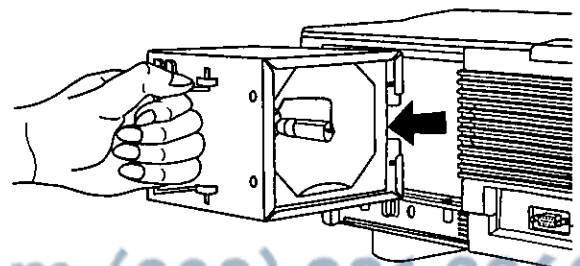
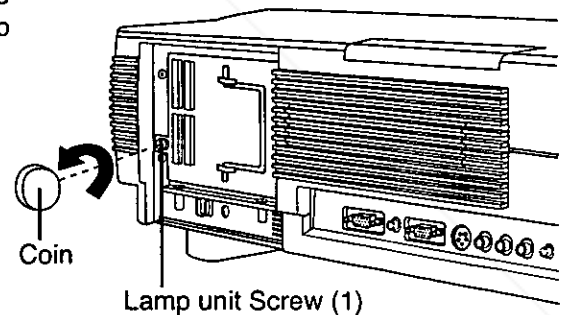
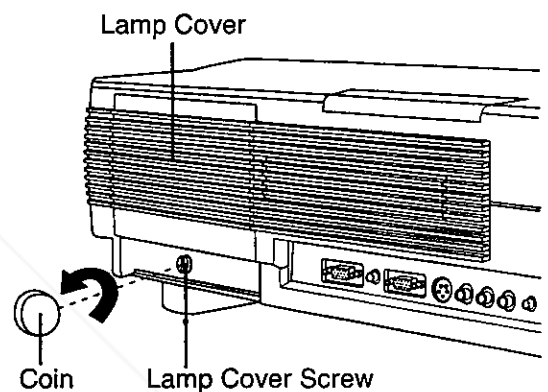

Warning Indicators

The warning lights on the LCD Projector indicate problems inside the projector.

- There are three warning lights; a LAMP indicator which warns of a problem with the lamp, a WARNING TEMP indicator which warns that the projector is too hot, and a REPLACE LAMP indicator which lets you know when to change the bulb.
- If a problem causes either the LAMP indicator or the WARNING TEMP indicator to light red, the power will automatically shut off. After turning off the Main Power Switch, follow the procedures given below.

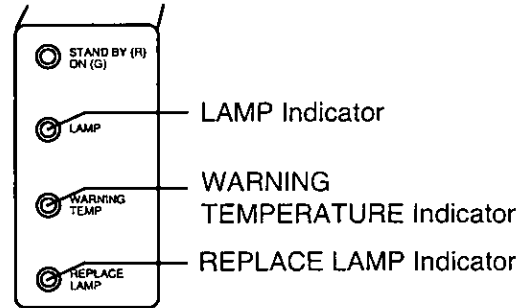
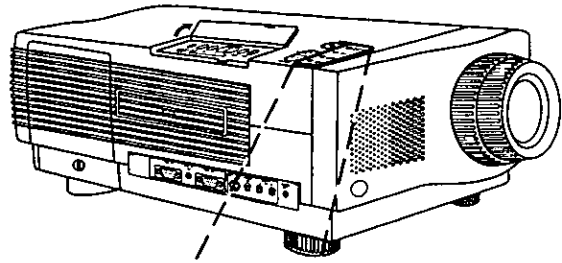

Warning Indicator	Symptom	Problem	Possible Solution
LAMP indicator	The lamp does not light up.	<ul style="list-style-type: none"> • Burnt-out lamp • Lamp circuit failure 	• Take the projector to your nearest Panasonic Service Center.
WARNING TEMP indicator	The internal temperature is abnormally high.	• Blocked air intake.	• Relocate projector to a proper location.
		• Clogged air filter.	• Clean the filter. (See page 26.)
		<ul style="list-style-type: none"> • Cooling fan breakdown. • Internal circuit failure. 	• Take the projector to your nearest Panasonic Service Center.
	The power cannot be turned on.	• Misinstalled Filter Holder.	• Filter Holder is properly installed. (See page 26.)
REPLACE LAMP indicator	REPLACE LAMP indicator starts flashing red 100 hours before lamp is completely used up. The indicator then turns to solid red.		• Replace the lamp. (See page 27.)

Notes:

- If the WARNING TEMP indicator light comes on after servicing, please wait until the projector has cooled down completely before turning the power back on. (At least 5 minutes.)

When the power is turned off and then turned on again, as during a brief rest, the LAMP indicator may be triggered, preventing the power from going on. When this happens, unplug the power plug from the AC outlet and plug it back in again.

Discount-Merchant.com (800) 281-8860
THE TRUSTED SOURCE FOR PROJECTOR LAMPS AND ACCESSORIES

Trouble Shooting

If the LCD Projector unit fails, check the following before calling your dealer for service.

Troubleshooting Chart

Yes: ———→ No: - - ->

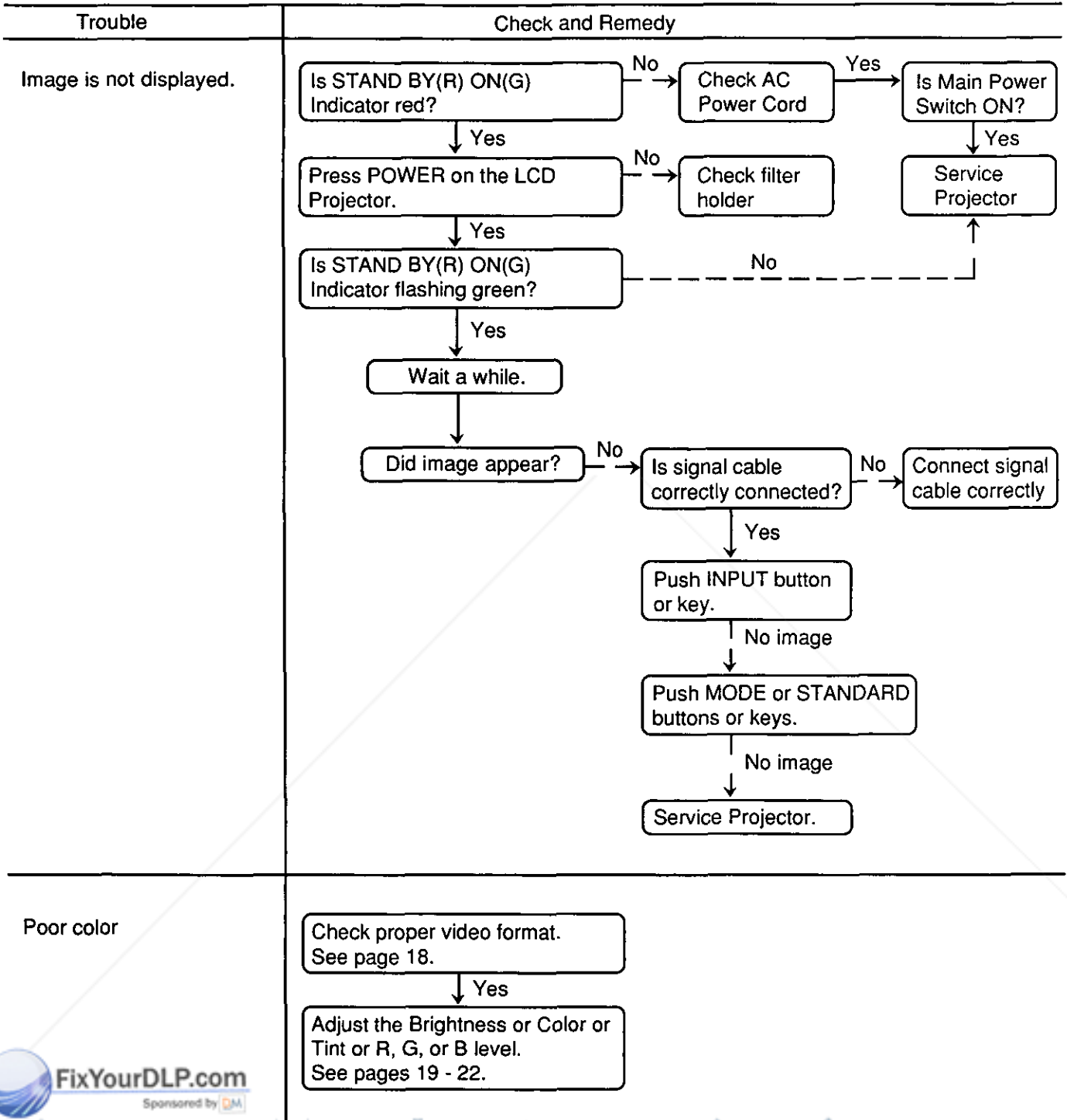

Discount-Merchant.com (800) 281-8860
THE TRUSTED SOURCE FOR PROJECTOR LAMPS AND ACCESSORIES

Trouble	Check and Remedy
Image is blurred.	<p>Adjust the Focus Ring.</p> <p>Yes</p> <p>Is the distance between LCD Projector and screen correct? No → Adjust the distance.</p> <p>Yes</p> <p>Has the lens become dirty? Yes → Clean the lens.</p> <p>No</p> <p>Are signal connection pin assignments correct? See page 12. No → Use a signal connector with correct pin assignments.</p> <p>Yes</p> <p>Is signal cable connected correctly? No → Connect signal cable correctly.</p>
Picture rolls.	<p>Are signal connector pin assignments correct? See page 12. No → Use a signal connector with correct pin assignments.</p> <p>Yes</p> <p>Is signal cable connected correctly? No → Connect signal cable correctly.</p> <p>Yes</p> <p>Does computer's sync signals match LCD Projector specifications. (See pages 23 - 25 specifications, Input signals, Horizontal frequency & Vertical frequency.)</p>

Yes: ———→ No: — — —→

Trouble	Check and Remedy
No sound.	<pre> graph TD A[Check if Audio cable is correctly connected.] -- No --> B[Connect Audio cable correctly.] A -- Yes --> C[Push INPUT button or key.] C -- No --> D[Push VOLUME + button or key.] </pre>
LCD Projector can not be remote controlled.	<pre> graph TD A[Are remote control batteries fresh?] -- No --> B[Replace the batteries. See page 8.] A -- Yes --> C[Is remote sensor on the unit blocked by obstacles?] C -- Yes --> D[Remove all obstacles.] C -- No --> E[Are operating distance and angle within specifications? Distance: 23 feet (7m) Angle: 30°] </pre>



Discount-Merchant.com (800) 281-8860
THE TRUSTED SOURCE FOR PROJECTOR LAMPS AND ACCESSORIES

Notes importantes concernant la sécurité



ATTENTION: Lire toutes ces instructions avant d'utiliser votre projecteur. Conserver le mode d'emploi en lieu sûr afin de pouvoir le consulter ultérieurement.

L'énergie électrique peut effectuer plusieurs fonctions utiles. Ce projecteur à affichage à cristaux liquides a été conçu et fabriqué pour répondre aux normes de sécurité en vigueur. Mais une UTILISATION INCORRECTE PEUT PROVOQUER UNE DECHARGE ELECTRIQUE OU UN INCENDIE. Afin de ne pas supprimer les protections incorporées dans ce projecteur à affichage à cristaux liquides, respectez les règles de base suivantes pour son installation, utilisation et réparation.

- 1 Débrancher le projecteur de la prise de courant murale avant d'entreprendre le nettoyage.
- 2 Ne pas appliquer des produits de nettoyage liquides ou des aérosols. Utiliser un chiffon doux et sec pour nettoyer le projecteur. Si le projecteur est très sale, tremper un chiffon dans un détergent neutre, bien essorer le chiffon, puis essuyer le boîtier et terminer en essuyant avec un chiffon doux. Ne pas utiliser un dépoussiéreur chimique ou un nettoyant lustrant parce qu'il risque de détériorer le boîtier et de décaper le revêtement de peinture.
- 3 Ne pas utiliser des accessoires non recommandés par Panasonic, car ils risquent de provoquer des dangers.
- 4 Ne pas utiliser le projecteur près de l'eau; par exemple, près d'une baignoire, un lavabo, un évier, une cuve à lessive, dans un sous-sol mouillé, près d'une piscine, etc. Ne jamais renverser de liquides dans le projecteur.
- 5 Ne pas placer le projecteur sur un chariot, un support ou une table instable. Le projecteur risque de tomber, ce qui pourrait provoquer des blessures graves à un enfant ou un adulte, et/ou endommager l'appareil. Utiliser uniquement avec un chariot ou un support recommandé par le fabricant et adapté à l'utilisation d'un projecteur à affichage à cristaux liquides.
- 6 Le montage au plafond, contre un mur ou sur une étagère doit se faire à l'aide d'un kit de montage agréé par le fabricant.
- 7 Le projecteur à affichage à cristaux liquides et le chariot doivent être déplacés avec soin. Des arrêts brusques, une force excessive et des surfaces inégales risquent de faire basculer l'équipement et le chariot.
- 8 Les fentes et orifices au dos et au fond du boîtier sont destinés à la ventilation. Afin de garantir un fonctionnement fiable du projecteur à affichage à cristaux liquides et de le protéger contre le surchauffement, ces orifices ne doivent pas être bloqués ou couverts. Ces orifices ne doivent jamais être couverts par un tissu ou un autre matériau. L'orifice du fond ne doit pas être bloqué en plaçant le projecteur à affichage à cristaux liquides sur un lit, un fauteuil, un tapis ou toute autre surface similaire. Le projecteur à affichage à cristaux liquides ne doit pas être placé près d'un radiateur ou sur le dessus ou près d'une cheminée. Le projecteur à affichage à cristaux liquides ne doit pas être encastré sauf si une ventilation correcte est assurée.
- 9 Le projecteur doit être utilisé uniquement avec le type de source d'alimentation indiquée au dos du projecteur ou dans les caractéristiques techniques. En cas de doute sur le type d'alimentation électrique de votre entreprise, consulter le revendeur de votre projecteur à affichage à cristaux liquides ou la compagnie d'électricité locale.
- 10 Ne rien poser sur le cordon d'alimentation. Ne pas placer le projecteur à affichage à cristaux liquides dans un endroit où le cordon sera sur un lieu de passage.
- 11 Respecter les avertissements et instructions marqués sur le projecteur à affichage à cristaux liquides.
- 12 Par mesure de sécurité, ce projecteur est équipé. S'il n'est pas possible d'insérer la fiche dans la prise, utiliser un adaptateur confier l'installation d'une prise de terre à un électricien. Ne pas essayer de modifier cette fiche secteur.
- 13 Pour améliorer la protection du projecteur à affichage à cristaux liquides pendant un orage ou lorsqu'il est laissé sans surveillance ou inutilisé pendant une longue période, débranchez la fiche de la prise murale et débranchez tous les câbles. Cela évite d'endommager le projecteur par la foudre et les surtensions des lignes d'alimentation.



- 14** Ne pas surcharger les prises murales et les cordons de rallonge avec trop d'appareils car cela risque de provoquer un incendie ou une décharge électrique.
- 15** Ne jamais enfoncer d'objets de quelque sorte dans le projecteur à affichage à cristaux liquides par les fentes du boîtier, car ils pourraient toucher des points dangereux sous haute tension ou générer des court-circuits, qui risquent de provoquer un incendie ou une décharge électrique.
- 16** Ne pas essayer de réparer le projecteur à affichage à cristaux liquides soi-même. L'ouverture ou l'écroulement des couvercles risque de vous exposer à une tension dangereuse ou à d'autres dangers. Confiez tous travaux de dépannage à un dépanneur qualifié.
- 17** Débrancher le projecteur à affichage à cristaux liquides de la prise murale et confiez le dépannage à un dépanneur qualifié dans les conditions suivantes:
 - A. Lorsque le cordon d'alimentation ou la fiche est endommagée ou effilochée.
 - B. Si du liquide a été renversé dans le projecteur à affichage à cristaux liquides.
 - C. Si le projecteur à affichage à cristaux liquides a été exposé à la pluie ou à l'humidité.
 - D. Si le projecteur à affichage à cristaux liquides ne fonctionne pas normalement lorsque les instructions d'utilisation ont été suivies. Réglez uniquement les commandes décrites dans les instructions d'utilisation; un réglage incorrect des autres commandes risque de provoquer des dégâts et nécessiteront souvent un travail approfondi par un technicien qualifié pour remettre le projecteur à affichage à cristaux liquides en état de fonctionnement normal.
 - E. Si le projecteur à affichage à cristaux liquides a subi une chute ou si le boîtier a été endommagé.
 - F. Lorsque le projecteur à affichage à cristaux liquides présente un changement distinct dans sa performance - cela signifie une nécessité de réparation.
- 18** A la fin de tout entretien ou réparation du projecteur à affichage à cristaux liquides, demandez au technicien du service après-vente d'effectuer une vérification de sécurité de routine afin de déterminer si le projecteur à affichage à cristaux liquides est en état de fonctionnement.
- 19** Lorsque le remplacement des pièces est nécessaire, s'assurer que le technicien du service après-vente a utilisé les pièces de remplacement spécifiées par le fabricant et ayant les mêmes caractéristiques que les pièces d'origine. Des substitutions non autorisées risquent de provoquer un incendie, une décharge électrique ou d'autres dangers.
- 20** Le filtre à air doit être nettoyé toutes les 100 heures de fonctionnement de la lampe. Le projecteur à affichage à cristaux liquides risque de devenir trop chaud si le filtre n'est pas nettoyé lorsque cela est nécessaire.
- 21** Si l'objectif est sale ou encrassé, le nettoyer avec un chiffon propre, mouillé. Ne jamais toucher l'objectif avec les doigts.
- 22** Ne pas regarder à travers l'ouverture et l'objectif pendant que le projecteur fonctionne, car cela risque de provoquer des lésions oculaires.



Discount-Merchant.com (800) 281-8860
THE TRUSTED SOURCE FOR PROJECTOR LAMPS AND ACCESSORIES

Lampe

La lampe du projecteur à affichage à cristaux liquides a une durée de vie limitée de 1100 heures environ. "LAMP TIME REMAINING 100h" sera affiché à l'écran lorsque la durée de service atteint 1000 heures. Ensuite, chaque fois que le projecteur est allumé, la durée de vie restante de la lampe sera affichée.

- Un affichage d'avertissement de 10 secondes (20 secondes lorsque le projecteur à affichage à cristaux liquides est allumé) apparaît toutes les 10 heures à partir de 1000 heures de fonctionnement jusqu'à 1090 heures. L'avertissement sera ensuite affiché toutes les heures à partir de 1090 heures de fonctionnement. L'affichage d'avertissement clignotera à partir de 1100 heures et continue à être affiché en chiffres négatifs.

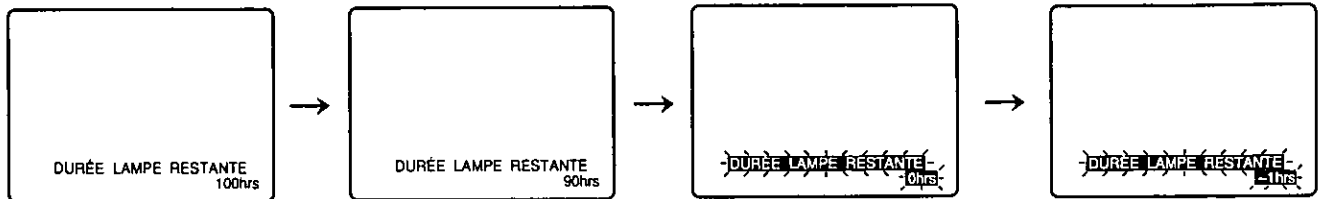

Remplacement de la lampe

Commander la lampe ET-LA201.

Outils nécessaires: Une pièce de monnaie.

- 1** Après l'arrêt du ventilateur de refroidissement et lorsque le voyant **STAND BY(R) ON(G)** devient rouge. Régler l'interrupteur d'alimentation sur OFF. Ensuite, débrancher le projecteur à affichage à cristaux liquides en retirant le cordon d'alimentation de la prise secteur du projecteur à affichage à cristaux liquides.
- 2** Lire d'abord les plaques de mise en garde et d'avertissement sur le couvercle de la lampe. Ensuite, retirer la vis du couvercle de la lampe (1) en utilisant la pièce de monnaie et détacher le couvercle de la lampe.
- 3** Attention, faire très attention. Le logement de la lampe est peut-être encore chaud au toucher. Retirer la vis de la lampe (1), puis saisir la poignée de la lampe et la tirer doucement du projecteur à affichage à cristaux liquides. Laisser l'ouverture du logement de la lampe à droite. Ne pas toucher la lampe ou pointer l'ouverture de la lampe sur quelqu'un.

AVERTISSEMENT: La lampe risque d'être chaude. Faire attention lors de sa manipulation.

ATTENTION: Une lampe sous haute pression risque d'exploser si elle n'est pas manipulée correctement.
- 4** Retirer soigneusement la lampe ET-LA201 de son emballage. Ne pas toucher la lampe ou pointer l'ouverture sur quelqu'un. Ne pas faire tomber, l'impact de la chute risque de provoquer l'explosion de la lampe. Installer une lampe neuve (ET-LA201) disponible auprès du service après-vente Panasonic.
- 5** Remettre la vis de la lampe et la vis du couvercle de la lampe en place en utilisant une pièce de monnaie pour la visser.
- 6** Brancher de nouveau le projecteur à affichage à cristaux liquides en insérant le cordon d'alimentation dans la prise secteur du projecteur à affichage à cristaux liquides et régler l'interrupteur d'alimentation sur ON.
- 7** Appuyer sur la touche **LAMP TIMER RESET** à l'aide d'un stylo à bille. Ne pas réinitialiser sauf si la lampe est remise en place. Le voyant de remplacement de la lampe s'éteint.
- 8** Eliminer la lampe usagée selon les prescriptions en vigueur.

Couvercle de la lampe

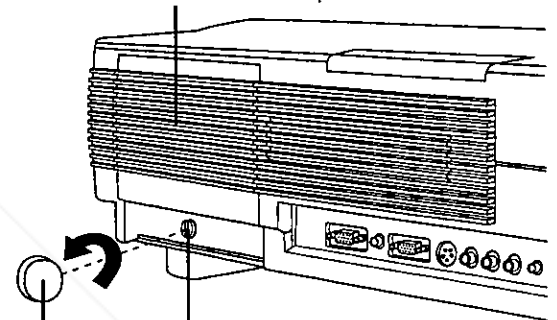

Pièce de monnaie Vis du couvercle de la lampe

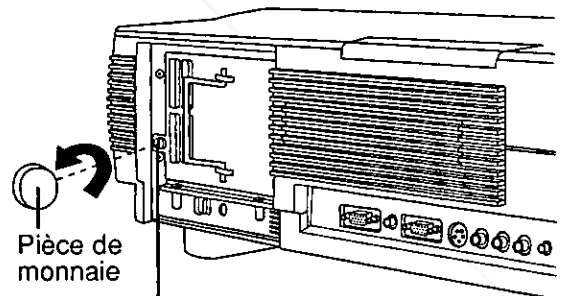

Pièce de monnaie Vis de la lampe (1)

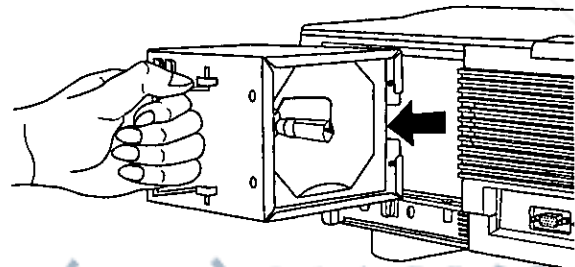

(Panneau de commande)

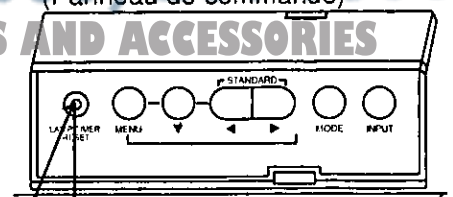

Touche **LAMP TIMER RESET**

Insérer un stylo ici



FixYourDLP.com

Sponsored by DML

Discount-Merchant.com (800) 281-8860

REPLACEMENT LAMPS AND ACCESSORIES

Panasonic®

Professional/Industrial Video

Panasonic Broadcast & Television Systems Company
Division of Matsushita Electric Corporation of America

Executive Office:

One Panasonic Way (3F-5), Secaucus, New Jersey 07094

EASTERN ZONE:

43 Hartz Way, Secaucus, NJ 07094 (201) 348-7620

CENTRAL ZONE:

1707 N. Randall Rd., Elgin, IL 60123 (847) 468-5200

SOUTHERN ZONE:

Dallas Region: 4500 Armon Carter Blvd., Fort Worth, TX 76155 (817) 685-1117

Atlanta Region: 1225 Northbrook Parkway, Suite 170, Suwanee, GA 30174 (770) 338-6855

WESTERN ZONE:

Los Angeles Region: 6550 Katella Ave., Cypress, CA 90630 (714) 373-7275

Government Marketing Department: 52 West Gude Drive, Rockville, MD 20850 (301) 738-3840

Matsushita Electric Corporation of America

Corporate Sales Group, Hawaii Region

99-859 Iwaiwa ST., Aiea, HI 96701-3267 (808) 488-7779

Panasonic Canada Inc.

5770 Ambler Drive, Mississauga, Ontario L4W 2T3 (905) 624-5010

Panasonic Sales Company

Division of Matsushita Electric of Puerto Rico, Inc.

San Gabriel Industrial Park, 65th Infantry Ave., K.M. 9.5, Carolina, PR 00630 (809) 750-4300

Printed in Japan
LSQT0033 (A)



Disclaimer

This user manual is provided as a free service by FixYourDLP.com. FixYourDLP is in no way responsible for the content of this manual, nor do we guarantee its accuracy. FixYourDLP does not make any claim of copyright and all copyrights remain the property of their respective owners.

About FixYourDLP.com

FixYourDLP.com (<http://www.fixyourdpl.com>) is the World's #1 resource for media product news, reviews, do-it-yourself guides, and manuals.

Informational Blog: <http://www.fixyourdpl.com>

Video Guides: <http://www.fixyourdpl.com/guides>

User Forums: <http://www.fixyourdpl.com/forum>

FixYourDLP's Fight Against Counterfeit Lamps:

<http://www.fixyourdpl.com/counterfeits>

Sponsors:

RecycleYourLamp.org – Free lamp recycling services for used lamps:

<http://www.recycleyourlamp.org>

Lamp Research - The trusted 3rd party lamp research company:

<http://www.lampresearch.com>

Discount-Merchant.com – The worlds largest lamp distributor:

<http://www.discount-merchant.com>



FixYourDLP.com

Sponsored by 