



Disclaimer

This user manual is provided as a free service by FixYourDLP.com. FixYourDLP is in no way responsible for the content of this manual, nor do we guarantee its accuracy. FixYourDLP does not make any claim of copyright and all copyrights remain the property of their respective owners.

About FixYourDLP.com

FixYourDLP.com (<http://www.fixyourdpl.com>) is the World's #1 resource for media product news, reviews, do-it-yourself guides, and manuals.

Informational Blog: <http://www.fixyourdpl.com>

Video Guides: <http://www.fixyourdpl.com/guides>

User Forums: <http://www.fixyourdpl.com/forum>

FixYourDLP's Fight Against Counterfeit Lamps:

<http://www.fixyourdpl.com/counterfeits>

Sponsors:

RecycleYourLamp.org – Free lamp recycling services for used lamps:

<http://www.recycleyourlamp.org>

Lamp Research - The trusted 3rd party lamp research company:

<http://www.lampresearch.com>

Discount-Merchant.com – The worlds largest lamp distributor:

<http://www.discount-merchant.com>



FixYourDLP.com

Sponsored by 

Panasonic®

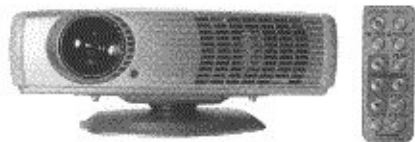

LCD PROJECTOR Operating Instructions Quick Reference Manual

Model No. **PT-LC50U**

Things You Should Know	2
Important Safeguards	3
Contents of LCD Projector Box	5
Before using the Remote Control Unit	6
Product Information	7
System Configuration Example	8
Turning the power on and off	9
Changing the input signal	10
Using the Auto Setup Feature	10
Menu operations	11
STATUS Code	12
Lamp, Air Filter	13
Specifications	14
Before Requesting Service	15



Please read these instructions completely before operating this LCD Projector.

This is a quick reference manual only. Please refer to the CD-ROM edition of the Operating Instructions for more detailed instructions.

Things You Should Know

Caution:

This equipment has been tested and found to comply with the limits for a Class B digital device, pursuant to Part 15 of the FCC Rules. These limits are designed to provide reasonable protection against harmful interference in a residential installation. This equipment generates, uses, and can radiate radio frequency energy and, if not installed and used in accordance with the instructions, may cause harmful interference to radio communications. However, there is no guarantee that interference will not occur in a particular installation. If this equipment does cause harmful interference to radio or television reception, which can be determined by turning the equipment off and on, the user is encouraged to try to correct the interference by one or more of the following measures:

- Reorient or relocate the receiving antenna.
- Increase the separation between the equipment and receiver.
- Connect the equipment into an outlet on a circuit different from that to which the receiver is connected.
- Consult the dealer or an experienced radio/TV technician for help.

Declaration of Conformity

Model Number:

PT-LC50U

Trade Name:

Panasonic

Responsible party:

Matsushita Electric Corporation of America.

Address:

One Panasonic Way Secaucus New Jersey 07094

Telephone number:

1-800-528-8601

This device complies with Part 15 of the FCC Rules, Operation is subject to the following two conditions: (1) This device may not cause harmful interference, and (2) this device must accept any interference received, including interference that may cause undesired operation.

FCC Warning:

To assure continued FCC compliance, use only the provided grounded power supply cord and prevent undesirable interference, use only the provided shielded VGA cable with 2 ferrite cores while connecting LCD to computer and all other connecting cables should be shielded. Any changes or modifications not expressly approved by the party responsible for compliance could void the user's authority to operate this equipment.

Warning: (E.U. only)

To assure continued CE Mark compliance, use only the provided earthed power supply cord and prevent undesirable interference, use only the provided shielded VGA cable with 2 ferrite cores while connecting LCD to compliance could void the user's authority to operate this equipment.

© 2000 Matsushita Electric Industrial Co., Ltd

All product/brand names are trademarks or registered trademarks of the respective holders.

Important Safeguards



CAUTION: Please read all of these instructions before you operate your LCD Projector. Save these instructions for future reference.

Electrical energy can perform many useful functions. This LCD Projector has been engineered and manufactured to meet applicable safety standards. But **IMPROPER USE CAN RESULT IN POTENTIAL ELECTRICAL SHOCK OR FIRE HAZARDS**. In order not to defeat the safeguards incorporated into this LCD Projector, observe the following basic rules for its installation, use and servicing.

- 1 Unplug the LCD Projector from the wall outlet before cleaning.
- 2 Do not use liquid cleaners or aerosol cleaners. Use a soft dry cloth to clean the LCD Projector unit. If the unit is very dirty, wet a cloth with neutral detergent, squeeze it tight, wipe the unit with it, and finish by wiping with a dry cloth. Do not use a chemical duster or polisher-cleanser because it can adversely affect the unit and peel the paint coat.
- 3 Do not use attachments not recommended by Panasonic, as they may cause hazards.
- 4 Do not use the LCD Projector near water; for example, near a bathtub, washbowl, kitchen sink, laundry tub, in a wet basement, near a swimming pool, etc. Never spill liquid into the LCD Projector.
- 5 Do not place the LCD Projector on an unstable cart, stand, or table. The LCD Projector may fall, which may cause serious injury to a child or an adult, and/or serious damage to the unit. Use only with a cart or stand recommended by its manufacturer, as being suitable for use with the LCD Projector.
- 6 The LCD Projector equipment and cart combinations should be moved with care. Quick stops, excessive force, and uneven surfaces may cause the equipment and cart combination to overturn.
- 7 Slots and openings in the cabinet back and bottom are provided for ventilation. To ensure reliable operation of the LCD Projector and to protect it from overheating, these openings must not be blocked or covered. These openings should never be covered with cloth or other material. The bottom opening should not be blocked by placing the LCD Projector on a bed, sofa, rug, or other similar surface. The LCD Projector should not be placed near or over a radiator or heating vent. The LCD Projector should not be placed in a built-in installation such as a bookcase unless proper ventilation is provided.
- 8 The LCD Projector should be operated only from the type of power source indicated on the back of the LCD Projector or in the specifications. If you are not sure of the type of power supplied to your home, consult your LCD Projector dealer or local power company.
- 9 Do not allow anything to rest on the power cord. Do not place the LCD Projector where the cord will be walked on.
- 10 Follow all warnings and instructions marked on the LCD Projector.
- 11 As a safety feature, the LCD Projector is equipped with a 3-prong grounded plug. The 3-prong grounded plug will fit only into a grounding type power outlet. If the plug does not fit, use an adaptor that is properly grounded or have an electrician install a grounded type outlet. Do not attempt to modify this AC plug.
- 12 For added protection of the LCD Projector during a lightning storm, or when it is left unattended or not in use for long periods of time, unplug it from the wall outlet and disconnect any cable systems. This will prevent damage to the projector due to lightning and power-line surges.



Important Safeguards

- 13 Do not overload wall outlets and extension cords with too many products, because this can result in fire or electric shock.
- 14 Never push objects of any kind into the LCD Projector through cabinet slots as they may touch dangerous voltage points or short out parts, which could result in a fire or electric shock.
- 15 Do not attempt to service the LCD Projector yourself. Opening or removing covers may expose you to dangerous voltage or other hazards. Refer all servicing to qualified service personnel.
- 16 Unplug the LCD Projector equipment from the wall outlet and refer servicing to qualified service personnel under the following conditions:
 - A. When the power cord or plug is damaged or frayed.
 - B. If liquid has been spilled into the LCD Projector.
 - C. If the LCD Projector has been exposed to rain or water.
 - D. If the LCD Projector does not operate normally when you follow the operating instructions. Adjust only those controls that are covered by the operating instructions; improper adjustment of other controls may cause damage and will often require extensive work by a qualified technician to restore the LCD Projector to normal operation.
 - E. If the LCD Projector has been dropped or the cabinet has been damaged.
 - F. When the LCD Projector exhibits a distinct change in performance – this indicates a need for service.
- 17 Upon completion of any service or repairs to the LCD Projector, ask the service technician to perform a routine safety check to determine that the LCD Projector is in safe operating condition.
- 18 When replacement parts are required, be sure the service technician has used replacement parts specified by the manufacturer that have the same characteristics as the original parts. Unauthorized substitutions may result in fire, electric shock, or other hazards.
- 19 Air filter should be cleaned every 100 lamp on hours. The LCD Projector may become too hot if filter is not cleaned when required.
- 20 If lens becomes dirty, or smudged, clean with a clean, dampened cloth. Never touch the lens with your fingers.
- 21 Do not look directly into the aperture and lens while operating as this may result in damage to your eyes.



Discount-Merchant.com (800) 281-8860
THE TRUSTED SOURCE FOR PROJECTOR LAMPS AND ACCESSORIES

Contents of LCD Projector Box

Please confirm that the following items are packed in the LCD Projector box. They are provided to help you use or set up your LCD Projector.

- (1) LCD Projector
- (2) Wireless Remote Control Unit (LSSQ0275)
- (3) CR2025 Lithium battery (Included with the remote control unit)
- (4) 9.8 ft UL/CSA Power Cord (LSJA0308)
- (5) VGA Cable (LSJA0239)
- (6) Video Cable (LSJA0074)
- (7) Audio Cable (LSJA0240)
- (8) Lens Cap (Included with the projector)
- (9) Carrying Bag (LSFC0015)
- (10) Swivel Stand (LSYC0162)
- (11) CD ROM (Operating Instructions)
- (12) Quick Reference Manual
- (13) Warranty Card
- (14) Service Center List



Discount-Merchant.com (800) 281-8860
THE TRUSTED SOURCE FOR PROJECTOR LAMPS AND ACCESSORIES

Before using the Remote Control Unit

Remote Control comes with battery inside. Please remove clear protective film before use.

■ Replacing the battery

Insert the new lithium battery making sure the polarities (+) and (-) are correct.

WARNING:

Replace battery with CR2025 only. Use of another battery may present a risk of fire or explosion.

Caution: Battery may explode if mistreated. Dispose of used battery promptly. Keep away from children. Do not recharge, disassemble or dispose of in fire.

- 1 While pushing the battery holder tab to the left, pull out the battery holder.

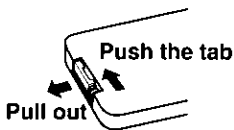

- 2 Insert the battery into the battery holder so that the + side is facing upward.

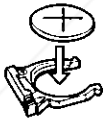

- 3 Insert the battery holder.

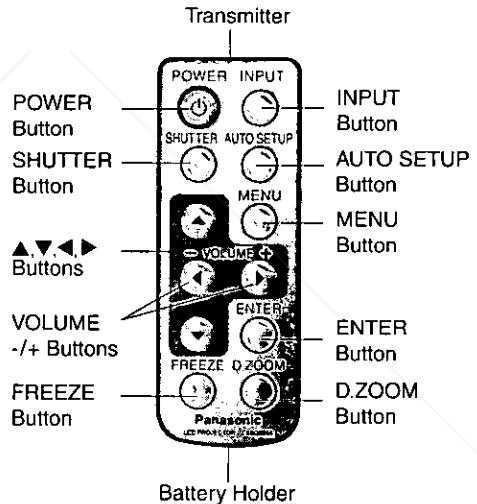

 FixYourDLP.com
Sponsored by
DiscountMerchant.com (800) 281-8860

Note THE TRUSTED SOURCE FOR PROJECTOR LAMPS AND ACCESSORIES

- Do not drop the remote control unit.
- Keep the remote control unit away from liquids.
- Remove the battery if not using the remote control unit for long periods.

Product Information

Labels on the unit are omitted.

■ Top, right and front

(In case Swivel Stand is installed.)

Adjust ▲▼◀▶
Buttons
(Also used for
Volume -/+)

ENTER
Button

MENU Button

KEYSTONE Button

INPUT Button

POWER Indicator
STANDBY (RED)
ON (GREEN)

POWER Button

STATUS Code
Indicator

Zoom Ring

Focus Ring

Air Outlet Port

Air Filter

Remote
Control
Sensor

Swivel Stand

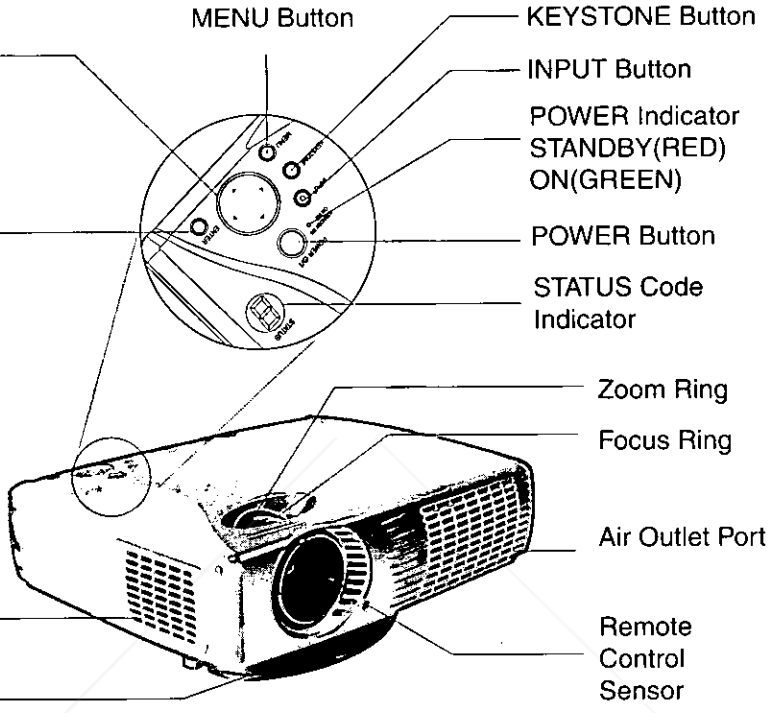

■ Back and bottom

Speaker

Remote Control
unit EJECT Button

AC Socket

Remote Control
unit Holder

Security Lock

Air Inlet Port
FixYourDLP.com
Sponsored by DLP

Remote
Control Sensor

Hole for Swivel
Stand
installation

Simple Stand

Lamp Cover

Discount-Merch.com (800) 281-8860
TRUSTED SOURCE FOR PROJECTOR LAMPS AND ACCESSORIES



System Configuration Example

■ Example of connection to audio-visual equipment

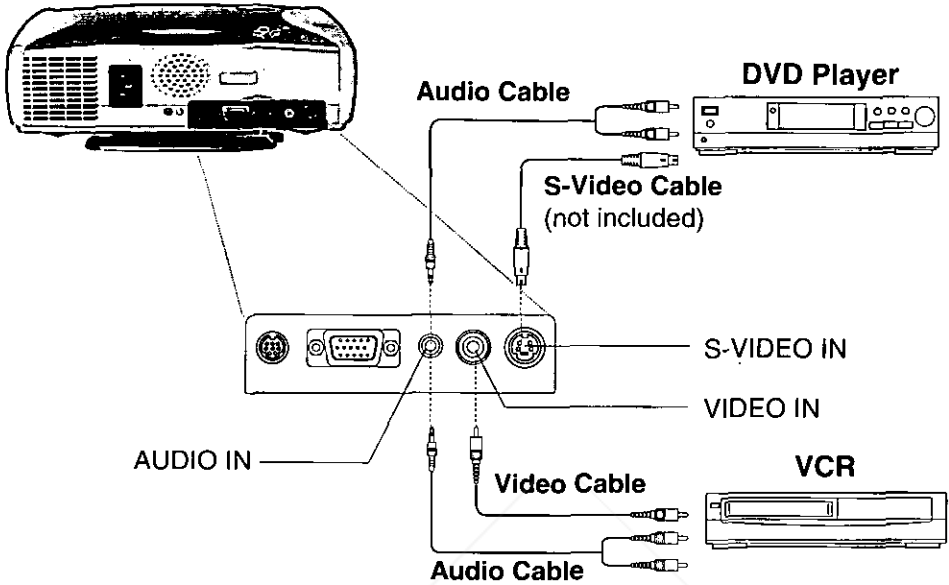

■ Example of connection to a Personal computer

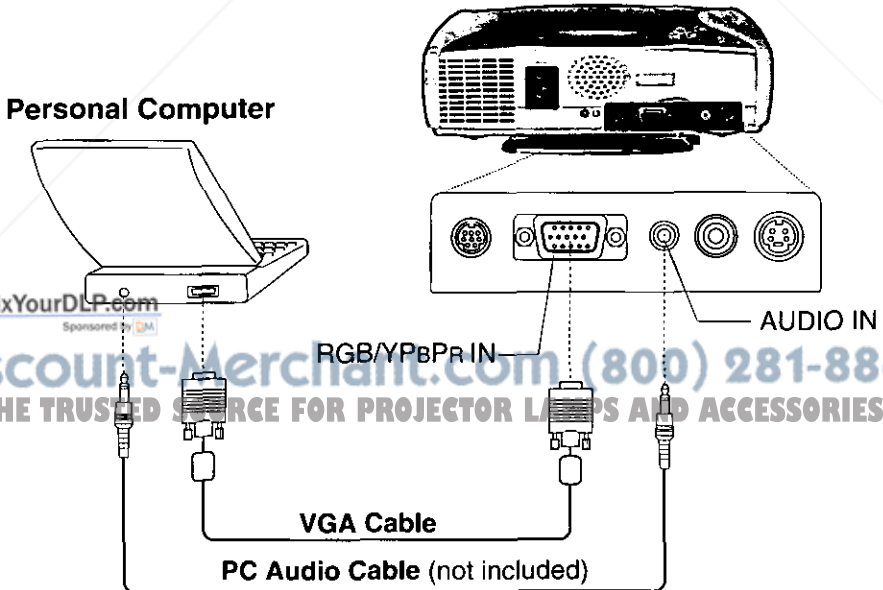

Turning the power on and off

POWER Button

POWER Indicator
STANDBY(RED)
ON(GREEN)

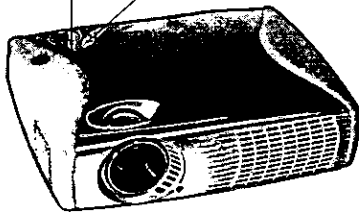

POWER Button

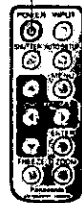

(Supplied)

Turning on the power

- 1 Press **POWER Button** on the LCD Projector or remote control unit.
- 2 The power indicator will flash, then turn solid green and a picture will be projected onto the screen.

Turning off the power

- 1 Press **POWER Button** on the LCD Projector or remote control unit. "Please press POWER button again to power off." is displayed on the screen, **and then press POWER button** again.
- 2 The power indicator will illuminate flashing red.
- 3 **Wait for the cooling fan to stop.**
The power indicator changes to solid red, the cooling fan stops, and the projector goes into Stand-by mode. (After about 1 minute)

Note

- The LCD Projector cannot be turned on for 60 seconds after turning it off.
- Insert Power Cord into LCD Projector AC socket and connect to properly grounded wall outlet.
- When power is turned off, the cooling fan continues to operate (approximately 60 seconds) in order to cool the projector interior.
- This unit consumes approx. 15 W in OFF condition when plugged into an AC outlet.

Changing the input signal

The input source for picture signals can be changed by pressing the INPUT Buttons on the projector operating panel or on the remote control unit.

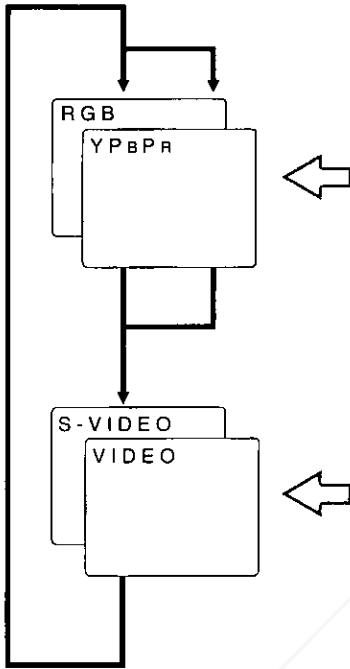

The signal from the source which is connected to the RGB/YPBPR connector is projected.

This terminal accepts input of RGB input signals from a personal computer and DTV Format signals (RGB, YPBPR) from a DVD or a digital broadcast. No monitor or projector can automatically decide whether a Component signal is the RGB-type or the YPBPR-type. So, you will have to select either RGB or YPBPR manually.

The signal from the source which is connected to the S-VIDEO IN connector or VIDEO IN connector is projected.

If cables are connected to both connectors, the S-VIDEO signal will be selected automatically. (The S-VIDEO signal has priority.)

Using the Auto Setup Feature

When projecting RGB signal images from a personal computer, it is possible to automatically adjust the image's position, dot clock and phase simultaneously (only for projection of images with RGB signal inputs other than DTV format signals). Perform the operation described below if you wish to use this function.



Press the **AUTO-SETUP** Button on the remote control unit.

THE TRUSTED SOURCE FOR PROJECTOR LAMPS AND ACCESSORIES

Auto Setup

Menu operations

This section explains how to reach the desired selection or setting screens from the MENU screen.

■ When an RGB signal is being projected. (for white balance adjustment of the red component)

1 Press the MENU Button.

The Main MENU screen will be displayed.

Use the **▲**, **▼** Buttons to select an item, and then **press the ENTER Button**.

The Second MENU screen will be displayed.

<input type="checkbox"/>	Picture
<input checked="" type="checkbox"/>	White Balance
<input type="checkbox"/>	Synchronization
<input type="checkbox"/>	Function
<input type="checkbox"/>	Language
<input type="checkbox"/>	Information

Main MENU screen

2 Press the ▲ or ▼ Buttons to select an item, and then press the ◀ or ▶ Buttons to change or adjust the setting.

<input type="checkbox"/>	White Balance	
R Level	0	<input type="text"/>
G Level	0	<input type="text"/>
B Level	0	<input type="text"/>
Standard (Push ENTER)		

Second MENU screen

■ Returning to the previous screen

If you press the MENU Button while a menu screen is being displayed, the display will return to the previous screen.

If you press the MENU Button while the Main MENU screen will be cleared.

■ Returning adjustment values to the factory default settings (standard values)

If "Standard" is selected while the "Second MENU" is displayed, the setting can be returned to the factory default setting.

However, the operation of this function varies depending on which screen is being displayed.

Use the **▲**, **▼** Buttons to select "Standard", and then **press the ENTER Button**.

<input type="checkbox"/>	Picture	
Image Quality	Dynamic	Natural
Brightness	0	<input type="text"/>
Contrast	0	<input type="text"/>
Standard (Push ENTER)		

STATUS Code

This LCD Projector has a STATUS Code display which calls your attention to problem conditions existing inside the LCD Projector. The LCD Projector displays a Status Code Indication each time an internal problem is detected. If any of the following indications appear in the STATUS Code display, immediately turn off the Power button, and then see the chart to determine a course of action.

STATUS Code	Symptom	Problem	Possible Solution
F-L	Lamp does not light up.	<ul style="list-style-type: none"> Cooling fan malfunction. 	<ul style="list-style-type: none"> Take the projector to your nearest Service Center.
C-0		<ul style="list-style-type: none"> Misinstalled Air Filter Unit or Lamp cover. 	<ul style="list-style-type: none"> Properly install Air Filter Unit or Lamp cover.
A-n		<ul style="list-style-type: none"> Temperature Sensor malfunction. 	<ul style="list-style-type: none"> Take the projector to your nearest Service Center.
A-0		<ul style="list-style-type: none"> Clogged air filter. Blocked air intake. The surrounding temperature of the place of use may be too high. 	<ul style="list-style-type: none"> Clean the filter. Relocate projector to a proper location. Place projector so that surrounding temperature is between 0 °C (32 °F) and 40 °C (104 °F) and the humidity is between 20 % and 80 % (with no condensation).
L-n		<ul style="list-style-type: none"> If the Lamp will not light after turning on the main power 2 or 3 times, the Lamp may be damaged. 	<ul style="list-style-type: none"> Take the projector to your nearest Service Center.
P-2		<ul style="list-style-type: none"> Lamp Voltage is not correct. 	
P-3		<ul style="list-style-type: none"> Abnormal temperature rise. 	
P-4		<ul style="list-style-type: none"> Other causes. 	
L-1	Lamp operation time is over 1 900 hours.	<ul style="list-style-type: none"> It is nearly time to replace the Lamp Unit. 	<ul style="list-style-type: none"> Replace the Lamp unit.
L-0	Lamp operation time reaches 2 000 hours.	<ul style="list-style-type: none"> The Lamp Unit must be replaced. 	
C-d	Forced cooling fan operating to expedite lamp replacement.	—	—

Lamp, Air Filter

Lamp replacement period

Warning

If the Lamp does not light and the LAMP STATUS Code is “L-n,” If the Lamp will not light after turning on the main power 2 or 3 times, the Lamp may be damaged. If the Lamp still does not light, the Lamp may be damaged. Because Lamp fragments could cause injury, DO NOT attempt to replace Lamp yourself. Take the LCD Projector to your dealer for repair.

The LCD Projector lamp has a limited operating life of approximately 2 000 hours. If lamp operation time exceeds 1 900 hours, “L-1” is displayed as the STATUS Code.

“Lamp replacement is recommended.” will be displayed on-screen when operation time reaches 1 900 hours.

Take the LCD Projector to your dealer for repair. (Order Lamp ET-LAC50.)

- When the lamp operation time has exceeded 1 900 hours, a warning will appear for 15 seconds when the LCD Projector power is turned on.

In case lamp time reaches 2 000 hours

The LCD Projector will shut itself OFF and the STATUS code indication becomes “L-0”.

- If the Lamp is not replaced, turning POWER on will only cause the screen to be displayed for 5 minutes.

Note

- The lamp used as the light source eventually wears out. The service life of the light source lamp used on the PT-LC50U is about 2 000 hours, but depending on the individual lamp's properties and the usage conditions the lamp may no longer light after less than 2 000 hours (the lamp is affected by the number of times the lamp is lit and the time span until it is relit, and these may shorten the service life). Because of this, we recommend having a replacement lamp on hand.

Air Filter

For Air Filter replacement procedure, please refer to the CD ROM manual.

The air filter should be cleaned about every 100 hours. Also, clean the air filter if the “A-0” is displayed in the STATUS Code display. Replace the filter when it is clogged or dirty even after cleaning.

Note

- If the dust cannot be removed by cleaning, it is time to replace the air filter. Consult a sales outlet.

CAUTION:

Operating LCD Projector with torn or damaged Filter may cause damage to LCD Projector.

Specifications

LCD panels		0.7" Poly silicon LCD panel X 3, RGB shutter method, using Translucent TN crystal panels	
Drive method		Active Matrix 4:3 Aspect Ratio panels, TFT (Thin Film Transistor)	
No. of pixels		480 000 (800 X 600) stripe pixels X 3 panels	
Lens		1-1.3 zoom lens, F2.3-2.6, f28 mm- 37 mm Manual Focus	
Projector lamp		130 W UHM Lamp	
Contrast ratio		300 : 1	
Brightness		700 lumen / ANSI	
No. of colors		16 777 216	
Screen size		30" - 300"	
Projection (throw) distance		1.6 m - 15.7 m	
Lens axis shift		6 : 1 Low position	
Color systems		PAL/SECAM/NTSC/PAL-M/PAL-N/NTSC4.43	
Video input signal		1 V [p-p], sync negative, 75 Ω terminated	
S-Video input signal		Y (luminance signal) : 1 V [p-p], sync negative, 75 Ω terminated C (chrominance signal) : burst 0.286 V [p-p], 75 Ω terminated	
Audio input signal		0.32 V [rms]	
Audio out		0.5 W Mono	
RGB input signal	Video signal	RGB Analog (0.7 V [p-p], 1.0 V [p-p] with sync on green, 75 Ω) YPbPr (Y: 1.0 V [p-p], Pb, Pr: 0.7 V [p-p], 75 Ω)	
	Sync signal	H/V separate, H/V composite, or Sync-on-Green	
	H-Frequency	24 KHz - 80 KHz (TTL Level)	
	V-Frequency	50 Hz - 86 Hz (TTL Level)	
Connectors		S-Video Input: Mini DIN 4-pin X 1 Video Input : RCA pin X 1 Audio Input: M3 stereo mini pin X 1 Serial Port (RS-232C): Mini DIN 8-pin X 1 RGB/YPbPr Input: D-Sub mini 15-pin X 1	
Controls	Cabinet Buttons/ Switches	Power ON/OFF, Menu, Input, ▲, ▼, ◀(Volume -), ▶(Volume +), Enter, Keystone	
	Remote Control Buttons	Power ON/OFF, Freeze, Shutter, Enter, Menu, Input, ▲, ▼, ◀(Volume -), ▶(Volume +), D.Zoom, Auto setup	
Speaker		36 mm round	
Operating Temperature		0 °C to 40 °C (32 °F to 104 °F)	
Operating Humidity		20 % - 80 % (non-condensing)	
Storage Temperature		-4 °F to 104 °F (-20 °C to 40 °C)	104 °F to 140 °F (40 °C to 60 °C)
Storage Humidity		5 % - 85 % (non-condensing)	Normal humidity
Power Supply		100 V - 240 V AC (50 Hz or 60 Hz) Automatic	
Power consumption		210 W	
Dimensions W x H x D		267 mm x 74 mm x 208 mm	
Weight		2.5 kg	
Approvals		FCC, UL, C-UL, CE, VDE	

Before Requesting Service

If the LCD Projector unit fails, check the following before calling your dealer for service.

Problem	Possible Cause
Power does not turn on.	<ul style="list-style-type: none"> • The power cord may not be connected. • The main power supply may not be supplied to the wall outlet. • The Status Codes are indicated on the STATUS Code display. • The lamp unit or lamp unit cover may not have been correctly installed. • The Air Filter Unit may not have been correctly installed.
No picture appears.	<ul style="list-style-type: none"> • The lens cap may still be attached to the lens. • The signal input source may not be connected properly. • The input selection setting may not be correct. • The Brightness adjustment may be lowest setting. • The LCD Projector may be set to the Shutter mode. • The connected signal source may be turned off.
The picture is fuzzy.	<ul style="list-style-type: none"> • The lens focus may not have been set correctly, or the projector may not be at the correct distance from the screen. • The lens may be dirty. • The LCD Projector may not be set up so that it is perpendicular to the screen. • The VIDEO or R, G, B adjustments may not have been set correctly.
Color is too light or tint is poor.	<ul style="list-style-type: none"> • Color or Tint adjustment may be incorrect. • The video formats may not match. • The signal cables may be connected incorrectly. For instance, the P_B, P_R connectors may be reversed.
No sound can be heard.	<ul style="list-style-type: none"> • The audio signal source may not be connected properly. • The volume adjustment may be at the lowest possible setting. • The Mute function or Audio/Video Shutter function may be active.
Remote Control does not operate.	<ul style="list-style-type: none"> • The batteries may be spent, or they may not be inserted correctly. • There may be an object blocking the infrared signals between remote control unit and the projector. • The remote control unit may be out of the operating range.
The color is black-and-white.	<ul style="list-style-type: none"> • The Video System may not be correct.



FixYourDLP.com
Sponsored by DM

Discount-Merchant.com (800) 281-8860

THE ONLY PLACE TO BUY PROJECTOR LAMPS AND ACCESSORIES

Panasonic®

Professional/Industrial Video

Panasonic Broadcast & Television Systems Company

Division of Matsushita Electric Corporation of America

One Panasonic Way 4E-7 Secaucus, NJ 07094 (201) 392-4443
3330 Cahuenga Blvd West Los Angeles, CA 90068 (323) 436-3500



Technical Support:

(800) 524-1448

(800) 526-6610

FAX: (201) 392-6514

E-Mail: pbtssupport@panasonic.com

Panasonic Canada Inc.

5770 Ambler Drive, Mississauga, Ontario L4W 2T3 (905) 624-5010

Printed in Japan

LSQT0324A

S1100-0



Disclaimer

This user manual is provided as a free service by FixYourDLP.com. FixYourDLP is in no way responsible for the content of this manual, nor do we guarantee its accuracy. FixYourDLP does not make any claim of copyright and all copyrights remain the property of their respective owners.

About FixYourDLP.com

FixYourDLP.com (<http://www.fixyourdlp.com>) is the World's #1 resource for media product news, reviews, do-it-yourself guides, and manuals.

Informational Blog: <http://www.fixyourdlp.com>

Video Guides: <http://www.fixyourdlp.com/guides>

User Forums: <http://www.fixyourdlp.com/forum>

FixYourDLP's Fight Against Counterfeit Lamps:

<http://www.fixyourdlp.com/counterfeits>

Sponsors:

RecycleYourLamp.org – Free lamp recycling services for used lamps:

<http://www.recycleyourlamp.org>

Lamp Research - The trusted 3rd party lamp research company:

<http://www.lampresearch.com>

Discount-Merchant.com – The worlds largest lamp distributor:

<http://www.discount-merchant.com>



FixYourDLP.com

Sponsored by 