



# Disclaimer

This user manual is provided as a free service by FixYourDLP.com. FixYourDLP is in no way responsible for the content of this manual, nor do we guarantee its accuracy. FixYourDLP does not make any claim of copyright and all copyrights remain the property of their respective owners.

About FixYourDLP.com

FixYourDLP.com (<http://www.fixyourdpl.com>) is the World's #1 resource for media product news, reviews, do-it-yourself guides, and manuals.

Informational Blog: <http://www.fixyourdpl.com>

Video Guides: <http://www.fixyourdpl.com/guides>

User Forums: <http://www.fixyourdpl.com/forum>

FixYourDLP's Fight Against Counterfeit Lamps:

<http://www.fixyourdpl.com/counterfeits>

## Sponsors:

RecycleYourLamp.org – Free lamp recycling services for used lamps:

<http://www.recycleyourlamp.org>

Lamp Research - The trusted 3rd party lamp research company:

<http://www.lampresearch.com>

Discount-Merchant.com – The worlds largest lamp distributor:

<http://www.discount-merchant.com>



**FixYourDLP.com**

Sponsored by 

# Panasonic

LCD Projector **Commercial Use**

## Operating Instructions

---

Model No. **PT-L6500U**  
**PT-L6600U**

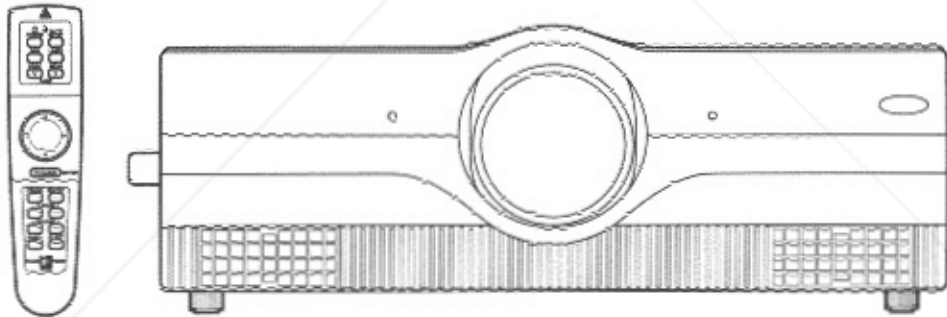

 **FixYourDLP.com**  
Sponsored by 

**Discount-Merchant.com (800) 281-8860**  
**THE TRUSTED SOURCE FOR PROJECTOR LAMPS AND ACCESSORIES**

Read these instructions completely before operating this unit.

# Dear Panasonic Customer:

This instruction booklet provides all the necessary operating information that you might require. We hope it will help you to get the most performance out of your new product, and that you will be pleased with your Panasonic LCD projector.

The serial number of your product may be found on its back. You should note it in the space provided below and retain this booklet in case service is required.

Model number: **PT-L6500U / PT-L6600U**

Serial number:

## IMPORTANT SAFETY NOTICE

**WARNING: TO REDUCE THE RISK OF FIRE OR ELECTRIC SHOCK, DO NOT EXPOSE THIS PRODUCT TO RAIN OR MOISTURE.**



The lightning flash with arrowhead symbol, within an equilateral triangle, is intended to alert the user to the presence of uninsulated “dangerous voltage” within the Product’s enclosure that may be of sufficient magnitude to constitute a risk of electric shock to persons.



The exclamation point within an equilateral triangle is intended to alert the user to the presence of important operating and maintenance (servicing) instructions in the literature accompanying the product.



FixYou.com  
Sponsored by DM

**Discount-Merchant.com (800) 281-8860**  
**THE TRUSTED SOURCE FOR PROJECTOR LAMPS AND ACCESSORIES**

**CAUTION:** This equipment is equipped with a three-pin grounding-type power plug. Do not remove the grounding pin on the power plug. This plug will only fit a grounding-type power outlet. This is a safety feature. If you are unable to insert the plug into the outlet, contact an electrician. Do not defeat the purpose of the grounding plug.

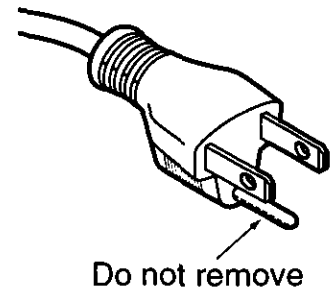

**WARNING:** This equipment has been tested and found to comply with the limits for a Class A digital device, pursuant to Part 15 of the FCC Rules. These limits are designed to provide reasonable protection against harmful interference when the equipment is operated in a commercial environment. This equipment generates, uses, and can radiate radio frequency energy and, if not installed and used in accordance with the instruction manual, may cause harmful interference to radio communications. Operation of this equipment in a residential area is likely to cause harmful interference in which case the user will be required to correct the interference at his own expense.

**CAUTION:** Any unauthorized changes or modifications to this equipment will void the users authority to operate



**Discount-Merchant.com (800) 281-8860**  
**THE TRUSTED SOURCE FOR PROJECTOR LAMPS AND ACCESSORIES**

# Contents

<b>IMPORTANT SAFETY NOTICE</b> .....	2	SIGNAL MODE .....	31
<b>Precautions with regard to safety</b> .....	5	STANDARD .....	31
<b>Caution</b> .....	6	<b>Adjusting the position</b> .....	<b>32</b>
<b>Accessories</b> .....	7	HORIZONTAL POSITION .....	32
<b>Precautions on handling</b> .....	8	VERTICAL POSITION .....	32
<b>Example of System up</b> .....	9	VIDEO SIZE .....	32
<b>Location and function of each part</b> .....	<b>10</b>	DOT CLK .....	32
Remote control .....	10	CLK PHASE .....	32
Projector <Top-Front and Side> .....	11	KEYSTONE .....	32
Projector <Top-Rear and Side> .....	12	V. LINEARITY .....	32
Projector <Rear control panel> .....	12	ASPECT .....	33
Projector <Interface panel> .....	13	STANDARD .....	33
<b>Using the Remote control unit</b> .....	<b>14</b>	<b>Adjusting the Zoom/Focus</b> .....	<b>33</b>
Loading batteries .....	14	ZOOM .....	33
Effective control range .....	14	FOCUS .....	33
Using laser pointer .....	15	<b>Changing the display language</b> .....	<b>33</b>
Setting projector IDs for remote control .....	15	<b>OPTION 1 settings</b> .....	<b>34</b>
Using the remote control as PC mouse .....	16	OSD (On-Screen Display) .....	34
Using the remote control in wired mode .....	17	RGB FORMAT .....	34
<b>Setting-up</b> .....	<b>18</b>	LENS SHIFT .....	34
Projection Schemes .....	18	BACK COLOR .....	34
Installation Geometry .....	18	PROJECTION SCHEME 1 .....	34
Projection Distances .....	18	PROJECTION SCHEME 2 .....	34
Setup precautions .....	19	<b>OPTION 2 settings</b> .....	<b>35</b>
Example of connecting with AV products .....	20	LAMP POWER .....	35
Example of connecting with PCs .....	21	LAMP SELECT .....	35
Example of connecting with system switcher .....	22	LAMP RUNTIME .....	35
<b>Starting to use</b> .....	<b>23</b>	SETTING FUNCTION 1 [FUNC 1] .....	35
Powering Up the Projector .....	23	SETTING UNIT ID .....	36
Making Initial Adjustment / Settings input port .....	23	Registering / Deleting / Displaying User Mode .....	36
Powering Off the Projector .....	23	<b>Using the SERIAL</b> .....	<b>37</b>
Leveling the Projector .....	24	Connection .....	37
Adjusting the Vertical Position of the Picture .....	24	Pin assignments and signal names .....	37
Advice on the installation of exhaust guides .....	25	Communication requirements .....	37
<b>Using the Freeze function</b> .....	<b>25</b>	Basic format .....	37
<b>Using the Shutter function</b> .....	<b>25</b>	Control command .....	38
<b>Using the Digital Zoom function</b> .....	<b>26</b>	Cable specifications .....	38
<b>On-screen menus</b> .....	<b>27</b>	USB control .....	38
Menu screens .....	27	<b>Using the remote terminal</b> .....	<b>39</b>
Basic Menu Operations .....	28	<b>Indication of lamp monitor</b> .....	<b>40</b>
Returning to the Previous Page .....	28	<b>Cleaning and replacing the air filter</b> .....	<b>41</b>
Menu Items Shown with White Characters .....	28	Cleaning method .....	41
Menu Items Setting .....	28	<b>Replacing the lamp unit</b> .....	<b>42</b>
Reset the Factory Default .....	28	Lamp replacement period .....	42
<b>Using the INDEX WINDOW function</b> .....	<b>29</b>	Lamp unit replacement steps .....	43
<b>Adjusting the picture</b> .....	<b>30</b>	<b>Before asking for service</b> .....	<b>45</b>
PICTURE MODE .....	30	<b>Specifications</b> .....	<b>46</b>
COLOR .....	30	<b>Appendix</b> .....	<b>48</b>
TINT .....	30	<b>Dimensions</b> .....	<b>49</b>
BRIGHT .....	30	<b>Trademark acknowledgments</b> .....	<b>50</b>
CONTRAST .....	30	<b>Français Information</b> .....	<b>51</b>
SHARPNESS .....	30		
TV-SYSTEM .....	31		
W-BALANCE R/G/B .....	31		

# Precautions with regard to safety

---

## WARNING

**If a problem occurs (such as no image or no sound) or if you notice smoke or a strange smell coming from the projector, turn off the power and disconnect the power cord from the wall outlet.**

- Do not continue to use the projector in such cases, otherwise fire or electric shocks could result.
- Check that no more smoke is coming out, and then contact an Authorized Service Center for repairs.
- Do not attempt to repair the projector yourself, as this can be dangerous.

**Do not install this projector in a place which is not strong enough to take the full weight of the projector.**

- If the installation location is not strong enough, it may fall down or tip over, and severe injury or damage could result.
- Installation work (such as ceiling suspension) should only be carried out by a qualified technician.
- If installation is not carried out correctly, there is the danger that injury or electric shocks may occur.

**If foreign objects or water get inside the projector, or if the projector is dropped or the cabinet is broken, turn off the power and disconnect the power cord from the wall outlet.**

- Continued use of the projector in this condition may result in fire or electric shocks.
- Contact an Authorized Service Center for repairs.

**Do not cover the air filter, the air inlet and exhaust vents.**

- Doing so may cause the projector to overheat, which can cause fire or damage to the projector.

**Do not overload the wall outlet.**

- If the power supply is overloaded (for example, by using too many adapters), overheating may occur and fire may result.

**Do not remove the cover or modify it in any way.**

- High voltages which can cause fire or electric shocks are present inside the projector.
- For any inspection, adjustment and repair work, please contact an Authorized Service Center.

**Clean the power cord plug regularly to prevent it from becoming covered in dust.**

- If dust builds up on the power cord plug, the resulting humidity can damage the insulation, which could result in fire. Pull the power cord out from the wall outlet and wipe it with a dry cloth.
- If not using the projector for an extended period of time, pull the power cord plug out from the wall outlet.

**Do not do anything that might damage the power cord or the power cord plug.**

- Do not damage the power cord, make any modifications to it, place it near any hot objects, bend it excessively, twist it, pull it, place heavy objects on top of it or wrap it into a bundle.
- If the power cord is used while damaged, electric Shocks, short-circuits or fire may result.
- Ask an Authorized Service Center to carry out any repairs to the power cord that might be necessary.

**Do not handle the power cord plug with wet hands.**

Failure to observe this may result in electric shocks.

**Insert the power cord plug securely into the wall outlet.**

- If the plug is not inserted correctly, electric shocks or overheating could result.
- Do not use plugs which are damaged or wall outlets which are coming loose from the wall.

**Do not place the projector on top of surfaces which are unstable.**

- If the projector is placed on top of a surface which is sloped or unstable, it may fall down or tip over, and injury or damage could result.

**Do not place the projector into water or let it become wet.**

- Failure to observe this may result in fire or electric shocks.

# Precautions with regard to safety

---

## **Do not place liquid containers on top of the projector.**

- If water spills onto the projector or gets inside it, fire or electric shocks could result.
- If any water gets inside the projector, contact an Authorized Service Center.

## **Do not insert any foreign objects into the projector.**

- Do not insert any metal objects or flammable objects into the projector or drop them onto the projector, as doing so can result in fire or electric shocks.

## **After removing the battery from remote control unit, keep it away from the reach of children.**

- The battery can cause death by suffocation if swallowed.
- If the battery is swallowed, seek medical advice immediately.

## **Do not allow the + and - terminals of the battery to come into contact with metallic objects such as necklaces or hairpins.**

- Failure to observe this may cause the battery to leak, overheat, explode or catch fire.
- Store the battery in a plastic bag and keep it away from metallic objects.

## **Insulate the battery using tape or similar before disposal.**

- If the battery comes into contact with metallic objects or other batteries, it may catch fire or explode.

## **A child is not made to use remote control and do not look into the laser beam emitted from the remote control.**

- Although laser emission from the remote control is not harmful to human health, do not look directly into the laser beam or aim it at another person.
- Laser radiation can cause injury to the human eye.

## Caution

### **Do not set up the projector in humid or dusty places or in places where the projector may come into contact with smoke or steam.**

- Using the projector under such conditions may result in fire or electric shocks.

### **When disconnecting the power cord, hold the plug, not the cord.**

- If the power cord itself is pulled, the cord will become damaged, and fire, short-circuits or serious electric shocks may result.

### **Always disconnect all cables before moving the projector.**

- Moving the projector with cables still attached can damage the cables, which could cause fire or electric shocks to occur.

### **Do not place any heavy objects on top of the projector.**

- Failure to observe this may cause the projector to become unbalanced and fall, which could result in damage or injury.

### **Do not short-circuit, heat or disassemble the battery or place it into water or fire.**

- Failure to observe this may cause the battery to overheat, leak, explode or catch fire, and burns or other injury may result.

### **When inserting the battery, make sure the polarities (+ and -) are correct.**

- If the battery is inserted incorrectly, it may explode or leak, and fire, injury or contamination of the battery compartment and surrounding area may result.

### **Use only the Specified battery.**

- If an incorrect battery is used, it may explode or leak, and fire, injury or contamination of the battery compartment and surrounding area may result close to this port, otherwise burns or damage could result.

**Do not look into the lens while the projector is being used.**

- Strong light is emitted from the projector's lens. If you look directly into this light, it can hurt and damage your eyes.

**Do not bring your hands or other objects close to the air outlet port.**

- Heated air comes out of the air outlet port. Do not bring your hands or face, or objects which cannot withstand heat

**Replacement of the lamp unit should only be carried out by a qualified technician.**

- The lamp unit has high internal pressure. It can easily become damaged if struck against hard objects or dropped, and injury or malfunctions may result.

**Replacement of the lamp unit should only be carried out after it has completely cooled off, otherwise burns may result.**

**Disconnect the power cord plug from the wall outlet as a safety precaution before carrying out any cleaning.**

- Electric shocks can result if this is not done.

**Ask an Authorized Service Center to clean inside the projector at least once a year.**







- If dust is left to build up inside the projector without being cleaned out, it can result in fire or problems with operation.
- It is a good idea to clean the inside of the projector before the season for humid weather arrives. Ask your nearest Authorized Service Center to clean the projector when required. Please discuss with the Authorized Service Center regarding cleaning costs.

**Do not reach for the openings beside the optical lens, during horizontal or vertical movements of the lens there is a injury hazard.**

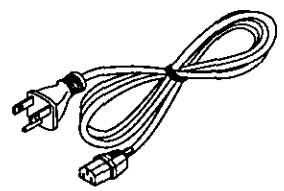
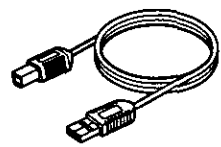
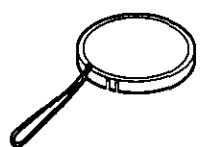
**An effort to keep our environment clean, Please bring the non repairable unit your Dealer or a Recycling Company.**

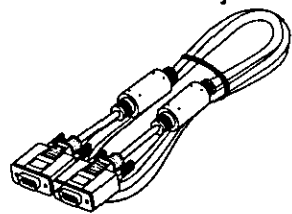
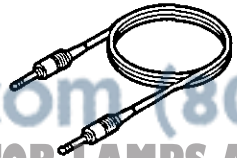
## Accessories

Check that all of the accessories shown below have been included with your projector.

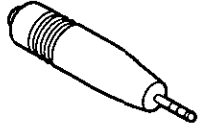
<p>Remote control unit [N2QAEA000003 x1]</p> 	<p>Power cord [K2CA3FZ00001 x1]</p> 	<p>USB cable [3.0 m (9' 10"), K1HB04FD0001 x1]</p> 	<p>Lens cover [TKKL5103 x1]</p> 
	<p>RGB signal cable (for VGA) [3.0 m (9' 10"), K1HB15FA0001 x1]</p> 	<p>Wired cable for remote control [15 m (49' 3"), K1EA03NA0001 x1]</p> 	<p>Battery for remote control unit [R03NPA/2ST x1]</p> 
		<p>Right-side exhaust guide [TPAKK21 x1]</p>  <p>Left-side exhaust guide [TPAKK22 x1]</p>  <p>Fixing pin [TPAMM33 x1]</p> 	<p>Conversion plug [K2RB031D0001 x1]</p> 



# Precautions on handling

## Cautions regarding transportation

**Be sure to attach the lens cover before transporting the projector.**

The projection lens is extremely susceptible to vibration and shocks. When carrying the projector. Be careful not to subject to excessive vibration or shock while under transport.

## Cautions regarding setting-up

Observe the following at all times when setting up the projector.

**Avoid setting up in places which are subject to vibration or shocks.**

If the projector is set up in locations with strong vibration, such as near a motor, or if it is installed inside a vehicle or on board a ship, the projector may be subjected to vibration or shocks which can damage the internal parts and cause malfunctions or accidents. Accordingly, set up the projector in a place which is free from such vibrations and shocks.

**Do not set up the projector near high-voltage power lines or near motors.**

The projector may be subject to electromagnetic interference if it is set up near high-voltage power lines or motors.

**If installing the projector to the ceiling, ask a qualified technician to carry out all installation work.**

If the projector is to be suspended from the ceiling, you will need to purchase the separate installation kit (Model No.: ET-PKL6500/S). Furthermore, all installation work should only be carried out by a qualified technician.

## Notes on use

**In order to get the best picture quality**

If outside light or light from indoor lamps is shining onto the screen, the images projected will not have good contrast. Draw curtains or blinds over any windows and turn off any fluorescent lights near the screen to prevent reflection.

Depending on the environment where used, hot air from the cooling fan vent may in rare cases cause disturbances on the screen.

**Do not touch the surfaces of the lens with your bare hands.**

If the surface of the lens becomes dirty from fingerprints or anything else, this will be magnified and projected onto the screen. Moreover, when not using the projector, cover it with the accessory lens cover.

**About the screen**

If the screen you are using is dirty, damaged or discolored, attractive projections cannot be obtained. Do not apply any volatile substances to the screen, and do not let it become dirty or damaged.

**Before carrying out cleaning and maintenance, be sure to disconnect the power cord plug from the wall outlet.**

**Wipe the cabinet with a soft, dry cloth.**

If the cabinet is particularly dirty, soak the cloth in water with a small amount of neutral detergent in it, squeeze the cloth very well, and then wipe the cabinet. After cleaning, wipe the cabinet dry with a dry cloth.

**If using a chemically-treated cloth, read the instructions supplied with the cloth before use.**

Do not wipe the lens with a cloth that is dusty or which produces lint.

If any dust or lint gets onto the lens, such dust or lint will be magnified and projected onto the screen. Use a blower to clean any dust and lint from the lens surface, or use a soft cloth to wipe off any dust or lint.

# Example of System up

The projector features a wealth of interface ports and optional parts that can be used to set up the projection system in diverse ways. The following presents some of those setup examples:

## System 1

Picture brightness can be doubled by stacking two projectors with the stacking brackets.

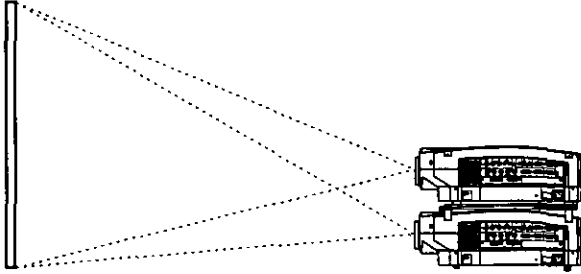

(It is an image figure using the simple mount bracket)

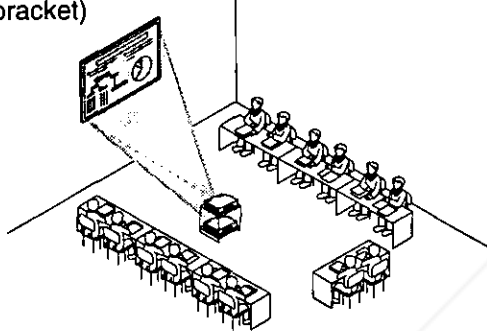

## System 2

The optional high- or low-ceiling mount bracket flexibly fits the projector in individual site conditions.

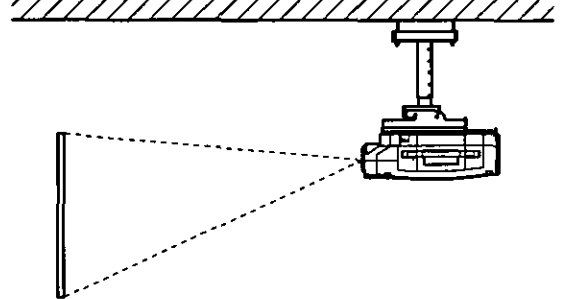

(It is an image figure using the Ceiling mount bracket)

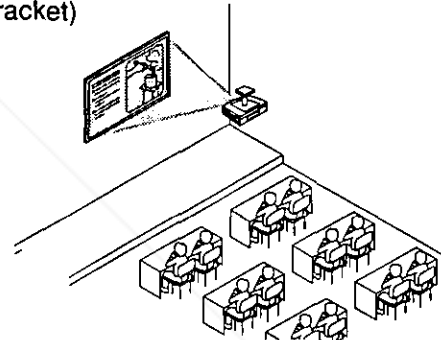

## System 3

PCs equipped with a DVI-D port can be attached to the projector for computer image viewing. (Realization of high clear picture.)

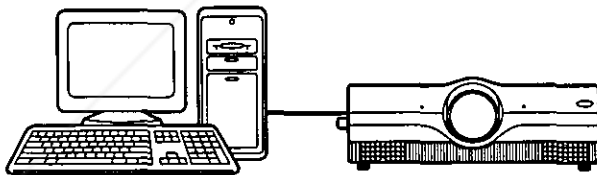

FixYourDLP.com  
Sponsored by DM

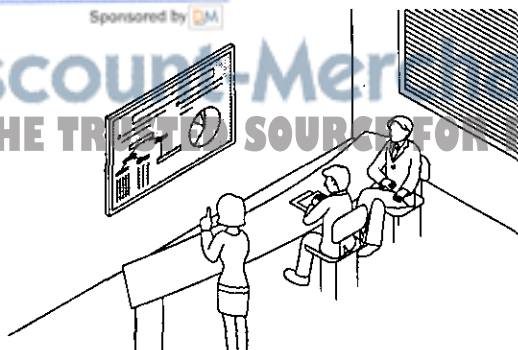

## System 4

A variety of video sources can be fed to the projector through a system switcher.

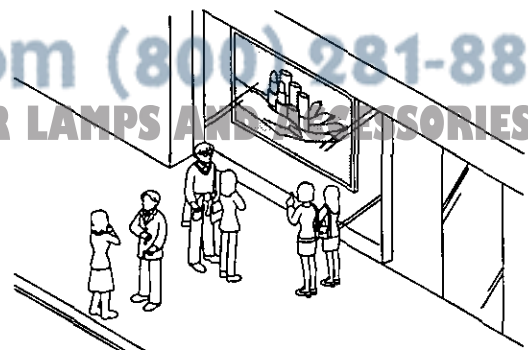
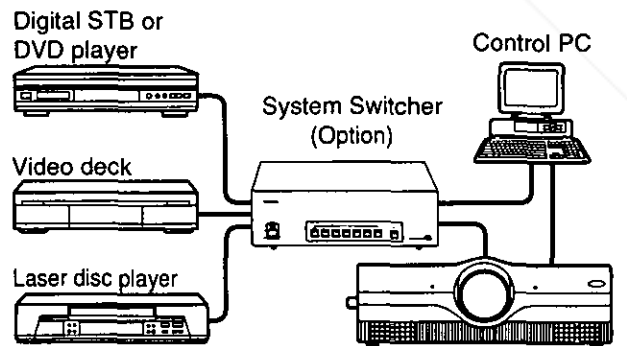

Discount-Merch.com (800) 281-8860  
THE TRUSTED SOURCE FOR PROJECTOR LAMPS AND ACCESSORIES

# Location and function of each part

## Remote Control

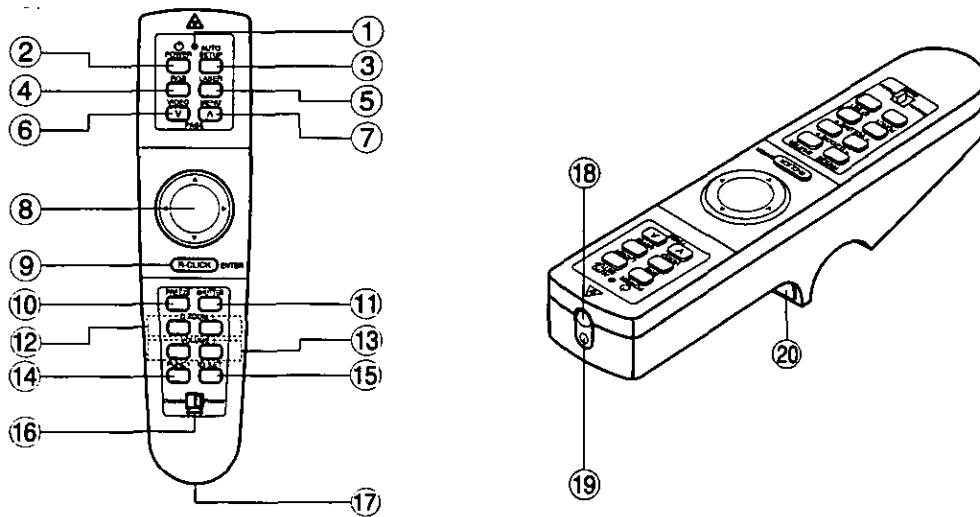

- ① Remote control operating indicator lamp**  
The light flashes when any remote control button other than the "LASER" button is pressed.
- ② POWER button (page 23)**  
Turns the projector ON/OFF when the MAIN POWER switch on the projector is set to "I".
- ③ AUTO SETUP button (page 23)**  
Pressing this button automatically corrects picture positioning on the screen. While the auto setup feature is active, the message "AUTO SETUP" appears on the screen.
- ④ RGB button (page 23)**  
Use to toggle through the RGB1, RGB2, and DVI-D input ports.
- ⑤ LASER button (page 15)**  
While this button is pressed and held, the remote control activates its laser transmitter to display a laser pointer on the screen.
- ⑥ VIDEO button (pages 16 and 23)**  
Use to toggle between the Composite Video and S-Video ports. The button acts as the Page Down button if the Mode switch ⑯ is set to the Computer position.
- ⑦ MENU button (pages 16, 27 and 28)**  
Main Menu display is switched on and off alternately each time this button is pressed. If the menu has multiple pages, this button may be used to view the next or previous menu page. The button acts as the Page Up button if the Mode switch ⑯ is set to the Computer position.
- ⑧ Arrow (▲▼◀▶) buttons (pages 16 and 28)**  
Use to choose menu items, change settings, or adjust control parameters. The button acts as a mouse, so can move the cursor if the Mode switch ⑯ is set to the Computer position.
- ⑨ ENTER button (pages 16 and 28)**  
Press this button to enter your menu selection or to run functions. The button acts as the right mouse button if the Mode switch ⑯ is set to the Computer position.
- ⑩ FREEZE button (page 25)**  
Press this button to temporarily freeze the image presently on the screen.
- ⑪ SHUTTER button (page 25)**  
Press this button to temporarily mute/black out both audio and video.
- ⑫ D.ZOOM (+/-) buttons (page 25)**  
Any portion of the picture can be enlarged.
- ⑬ VOLUME (+/-) buttons (page 27)**  
Use these buttons to adjust the volume level from the internal speakers or line levels on the AUDIO OUT lines.
- ⑭ FUNC1 button (page 35)**  
Use to select from the functions listed on the "OPTION2" screen that can be chosen from the MAIN MENU.
- ⑮ ID SET button (page 15)**  
Use to set the projector ID when multiple PT-L6500U/L6600U projectors are used in the system.
- ⑯ Mode switch (Computer/Projector) (page 16)**  
When controlling the projector, set this switch to the Projector (right) side. When controlling your PC, set it to the Computer (left) side.
- ⑰ Wired Remote Control port (page 17)**  
When using wired remote control, connect the remote control to the projector with the accessory wired remote control cable.
- ⑱ Remote Control Transmitter Window**  
Whenever operating the Remote Control, aim this window to the projector's remote control receiver window.
- ⑲ Laser Transmitter Window**
- ⑳ Click button (page 16)**  
The button acts as the left mouse button if the Mode switch ⑯ is set to the Computer position.

## Projector < Top · Front and Side >

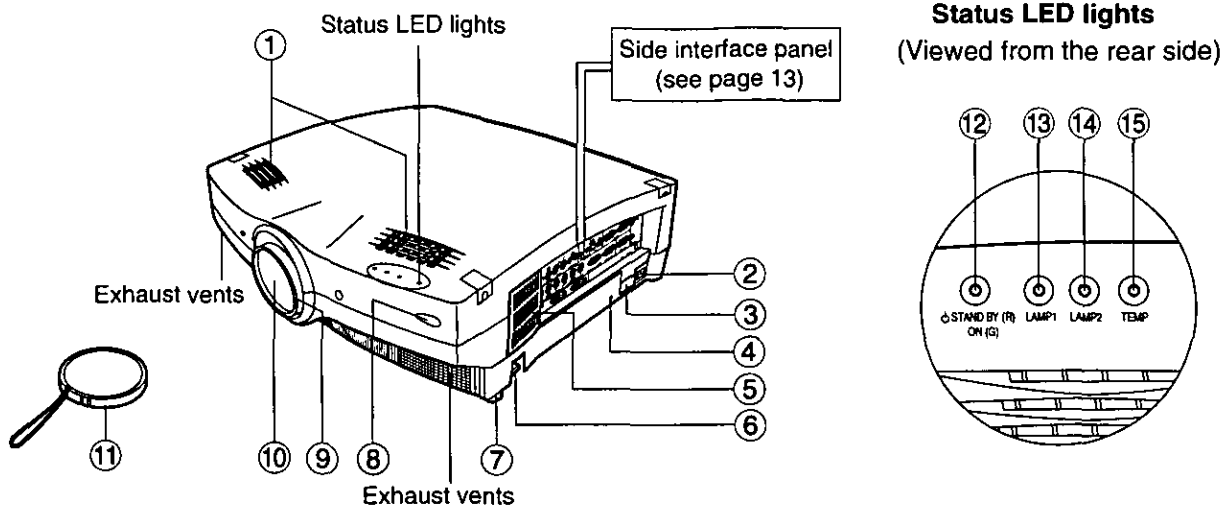

### ① Speakers

Speakers deliver a total audio output power of 6 watts (3 + 3 watts each).

### ② Line input (AC IN) socket (page 23)

Connect the accessory line power cord into this receptacle. Do not connect any other cord to this socket.

### ③ MAIN POWER switch (page 23)

Use this switch to turn "I" "O" the commercial line power applied to the projector.

### ④ Burglar lock

Attach a commercial burglar prevention cable (e.g. from Kensington) to this lock port. It is compatible with the Micro Saver Security System from Kensington. This security lock is compatible with the Microsaver Security System from Kensington. Contact details for this company are given below.  
Kensington Technology Group ACCO Brands Inc.  
2885 Campus Drive San Mateo, CA 94403  
Tel (650)572-2700  
Fax (650)572-9675  
<http://www.kensington.com/>  
<http://www.gravis.com/>

### Air filter (page 41)

### Leveling button (page 24)

Use these buttons (one on each side) to level the projector when resting on its feet.

### ⑦ Leveling foot (page 24)

Use in conjunction with ⑥ for the projector's tilt adjustment.

(A leveling foot is provided on each side of the unit.)

### ⑧ Remote control receiver window (page 14)

Receives IR commands transmitted from the remote control.

### ⑨ Focus ring (page 23)

For focus adjustment.

Powered focus adjustment is also available.

### ⑩ Projection lens

Images are projected onto the screen through this lens.

### ⑪ Lens cap

Cap the lens whenever the projector is left unused.

### ⑫ Power status light (page 23)

Lit in red when the projector is in standby mode with MAIN POWER switch set to "I". Lit in green when the unit is turned ON.

### ⑬ Lamp 1 monitor (page 40)

Lights when lamp unit 1 requires replacement. Flashes if the lamp 1 drive circuit is malfunctioning.

### ⑭ Lamp 2 monitor (page 40)

Lights when lamp unit 2 requires replacement. Flashes if the lamp 2 drive circuit is malfunctioning.

### ⑮ Temperature (TEMP) monitor light (page 40)

Warns of unacceptable internal temperatures. May be either continuously lit or flashing.

# Location and function of each part

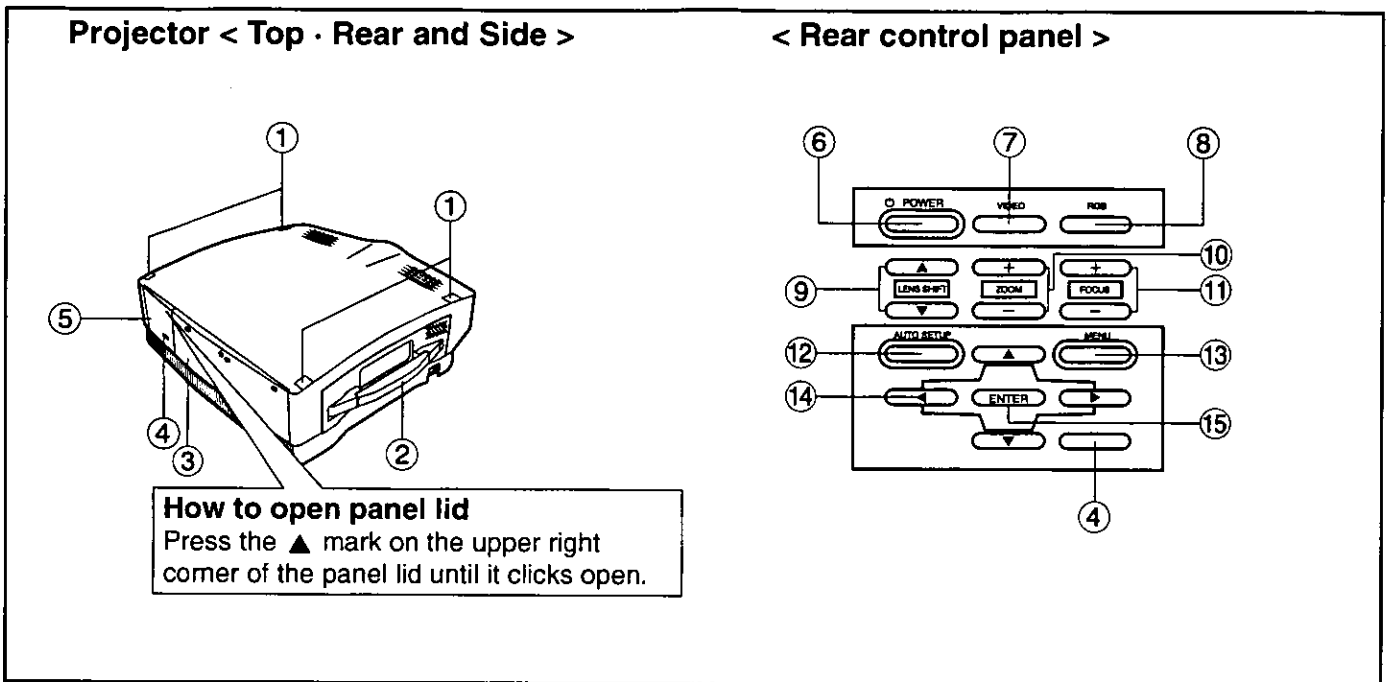

**① Stack Lid**

When two projectors are to be stacked, use this lid for positioning.

**② Carrying handle**

Pull out this handle to carry the unit.

**③ Lamp unit compartment (page 43)**

Houses the lamp unit.

**④ Rear side remote control receiver window (page 14)**

Receives commands transmitted from the remote control.

**⑤ Control subpanel lid**

Open this lid to access the control subpanel.

**⑥ POWER switch (page 23)**

Turns the unit ON/OFF.

**⑦ VIDEO button (page 23)**

Use to select video signal format from composite video and S-video.

**⑧ RGB button (page 23)**

Use to select RGB signal source from those connected to the RGB1, RGB2 and DVI ports.

**⑨ LENS SHIFT buttons (page 24)**

Pressing the ▲ or ▼ button tilts the projection lens to move the picture on the screen up or down accordingly.

**⑩ ZOOM buttons (page 23)**

Adjust the picture size on the screen with the “+” or “-” buttons.

**⑪ FOCUS buttons (page 23)**

Adjust focus with the “+” or “-” buttons.

**⑫ AUTO SETUP button (page 23)**

Pressing this button automatically corrects picture positioning on the screen. While the Auto setup feature is active, the message “AUTO SETUP” appears on the screen.

**⑬ MENU button (pages 27 and 28)**

Main Menu display is switched on and off alternately each time this button is pressed. If the menu has multiple pages, this button can be used to view the next or previous menu page.

**⑭ ARROW (▲ ▼ ◀ ▶) buttons (page 28)**

Use to choose menu items, change settings, or adjust control parameters.

**⑮ ENTER button (page 28)**

Press this button to enter your menu selection or to run functions.

< Interface panel >

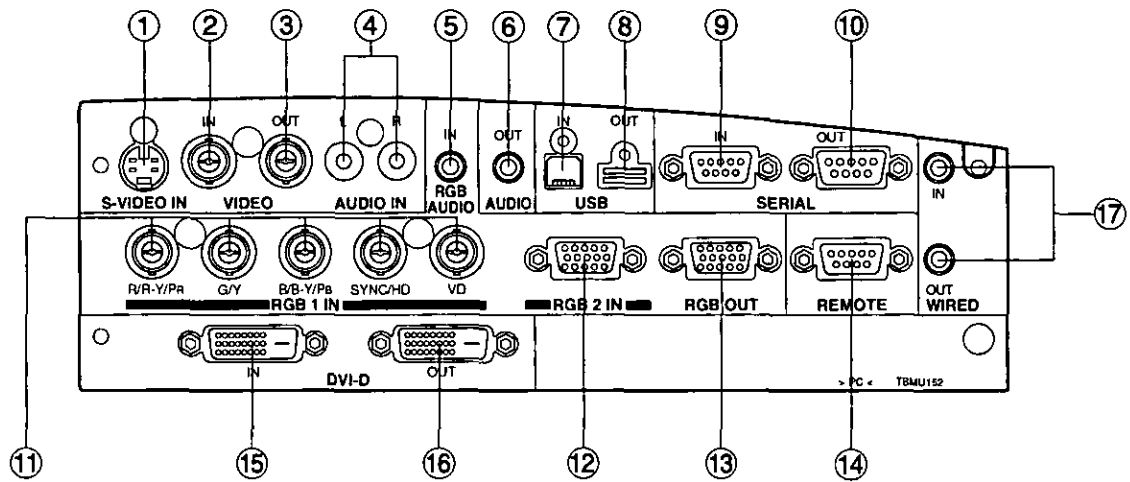

① **S-VIDEO IN port (pages 19, 20, and 33)**

Connect an S-video signal source to this port. Depend on input signal, screen aspect will automatically change 16:9 or 4:3.

② **VIDEO IN port (pages 20 and 22)**

Connect a composite video signal source to this port. (BNC)

③ **VIDEO OUT port (pages 20 and 22)**

Composite video signal appears at this port. (BNC)

④ **AUDIO IN L-R jacks (page 20)**

Only a single pair of audio inputs is available. Change connections to these jacks according to your choice of video source from composite and S-video (RCA jacks).

⑤ **RGB AUDIO IN jack (pages 20 and 21)**

Only a single pair of audio inputs is available. Change connections to these jacks according to your choice of video source from RGB1, RGB2, and DVI-D (M3 jacks).

⑥ **AUDIO OUT jack (page 20)**

The audio signals applied to the AUDIO IN or RGB AUDIO IN jacks of this unit appear at this jack. Once a cable is plugged into this jack, the signal lines to the internal speakers are cut off. (M3 jack)

**USB IN ports (pages 16, 21 and 38)**

The remote control can be used as your PC mouse by connecting the projector to your PC with the supplied USB cable. (4-pin square connector)

⑧ **USB OUT ports**

The control ports on two or more projectors can be connected to each other for interlocked control operations. (Type B)

⑨ **SERIAL IN port (pages 20, 21, 22 and 37)**

Use the RS-232C serial port as an alternative interface for controlling the projector from your PC. (D-SUB 9 pin)

⑩ **SERIAL OUT port (pages 21 and 22)**

The signal applied to the serial input port appears at this port (9-pin D-sub female connector).

⑪ **RGB1 (YPbPr) input ports (pages 20, 21 and 22)**

Apply RGB or YPbPr video to these ports. (BNC)

⑫ **RGB2 (YPbPr) IN port (page 21)**

RGB video input port. (D-SUB 15 pin)

⑬ **RGB OUT port (pages 21 and 22)**

The signals applied to RGB1 or RGB2 input ports appear at this port (15-pin D-sub female connector).

⑭ **REMOTE port (page 39)**

This port may be used to control the projector from the Remote Control set up in Wired mode. (9-pin D-sub female connector)

⑮ **DVI-D IN port (pages 19 and 21)**

DVI-D signals are applied to this port. (24-pin DVI connector)

⑯ **DVI-D OUT port (page 21)**

The signal applied to the DVI-D input port appears at this port (24-pin DVI connector).

⑰ **WIRED IN/OUT ports (page 17)**

Use to connect multiple PT-L6500U/L6600U projectors in a daisy chain to simultaneously control them from a single wired remote control. (M3 jack)

# Using the Remote control unit

## ■ Loading batteries

When loading batteries into the battery compartment of the remote control, make sure that their polarities are correct.

### 1. Open battery compartment lid.

Open lid in the order of steps ① and ②.

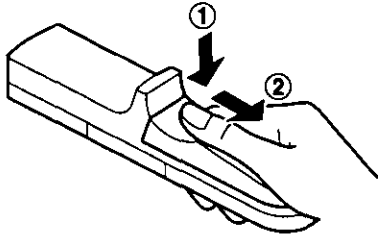

### 2. Insert the batteries

Into battery compartment, with their polarities orientated as indicated (+/-) in the compartment.

Accessory type-AAA dry batteries (insert the negative side first).

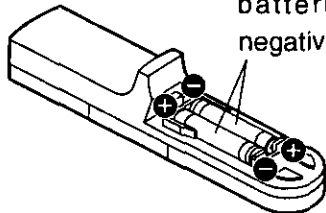

### 3. Close battery compartment lid.

Replace the battery compartment lid over the compartment and slide until it clicks.

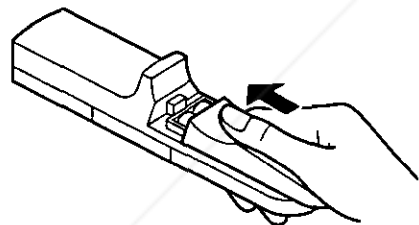

#### Caution

- Exercise care not to drop the remote control on hard flooring.
- Exercise care not to spill water or any other liquid on the remote control.

Do not use Ni-Cd batteries with this remote control.

## ■ Effective control range

The remote control should normally be aimed at either the front or rear remote control receiver window on the projector (fig. 1). Otherwise it may also be aimed at the screen, which will reflect commands back to the projector's front receiver window as illustrated in figure 2.

The effective control range is approx. 7 meters (23 feet) immediately in front of the receiver windows.

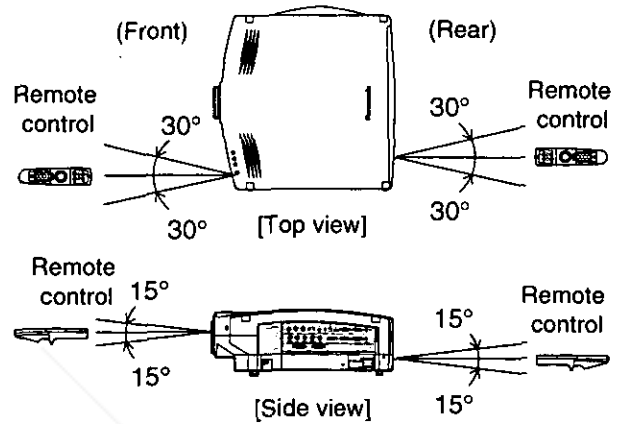

fig. 1

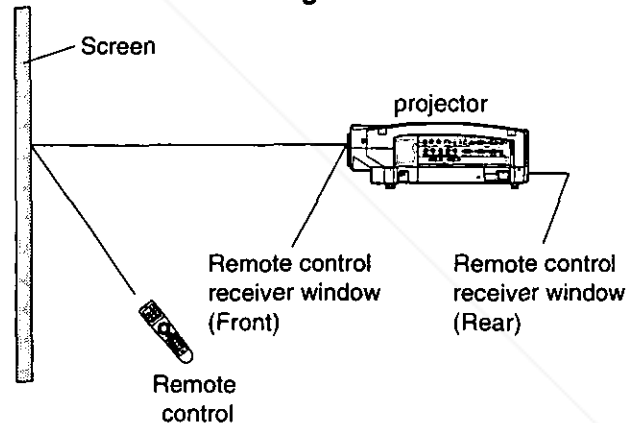

fig. 2

#### Note

- When the remote control is aimed at the screen, the effective control range may be reduced due to the optical loss of the screen.
- The remote control may not function properly if an object is in the light path.
- The remote control receiver may not function properly in intense ambient light. Carefully site the projector so its remote control receiver windows will not be directly exposed to intense light.



FixYouDIt.com Do not use Ni-Cd batteries with this remote control.

Discount-Merchant.com (800) 251-8860  
THE TRUSTED SOURCE FOR PROJECTOR LAMP, LAMP ACCESSORIES

## ■ Using laser pointer

The remote control contains a laser source that can appear as a colored spot on the screen which you can use as a pointer. The laser beam is activated while the "LASER" button is pressed and held.

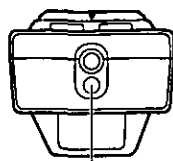

Laser Transmitter Window

### Warning

**DO NOT STARE INTO THE LASER BEAM OR AIM IT AT ANY PERSON'S EYE. LASER RADIATION CAN CAUSE SERIOUS INJURY TO THE HUMAN EYE.**

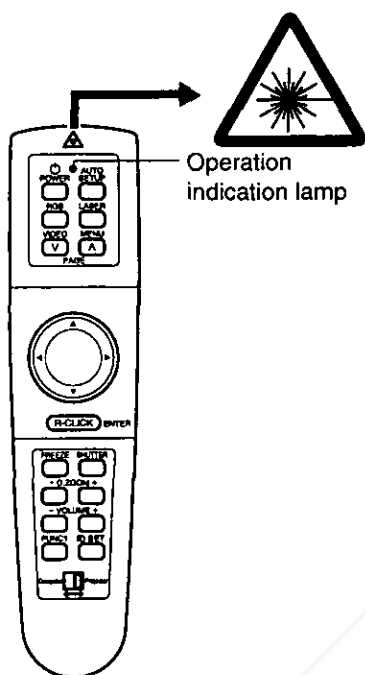

Operation indication lamp

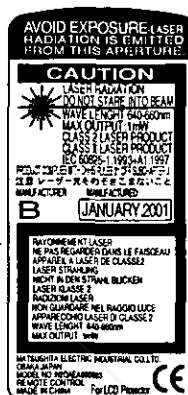
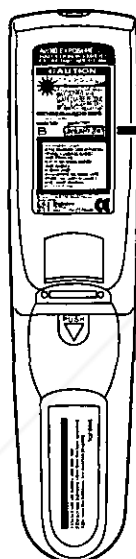

#### Laser Specifications:

Wavelength: 640 to 660 nm

Output power: 1 mW (Class II)

### Caution

- Use of controls or adjustments or performance of procedures other than those specified herein may result in hazardous radiation exposure.
- This remote control unit cannot be repaired.

## ■ Setting projector IDs for remote control

When controlling multiple projectors individually or simultaneously with a single remote control, projector IDs must be set into the remote control as described in the following steps:

### 1. Press the "ID SET" button on remote control.

ID number "ALL" will be displayed on the OSD.

### 2. Press and hold the "ID SET" button for more than 2 seconds.

The ID number will change into "1". The "ID SET" button will now toggle through ID numbers "2", "3", "ALL", "1", and so on each time it is subsequently pressed.

### 3. Select the ID number you wish and then press the "ENTER" button.

#### Note

- The projector ID number in the remote control is set to "ALL" by default. It is therefore not necessary to set a projector ID number when only one projector is used.
- The projector can be turned ON/OFF from the remote control only if the projector ID is set in the remote control. For more details on projector ID setting, see page 36.



# Using the Remote control unit

## ■ Using the remote control as a PC mouse

You can use the remote control as your PC mouse. Set the Mode (Projector/Computer) switch on the remote control to Computer and connect the projector's USB port to your PC counterpart with the accessory USB cable.

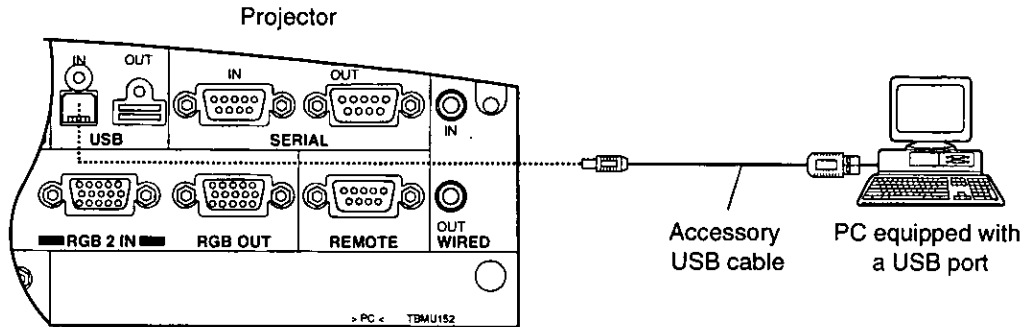

- When your PC is attached to the projector for the first time, the “new hardware wizard” will launch automatically. When USB cable connects for the first time between projector and PC, the following message appear from PC. The reason that the driver not installed, therefore press “NEXT” button continuously and finally. Press “Finish”.

### The following is in the case of Windows

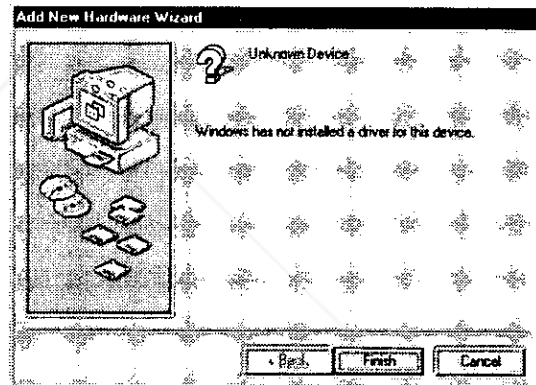
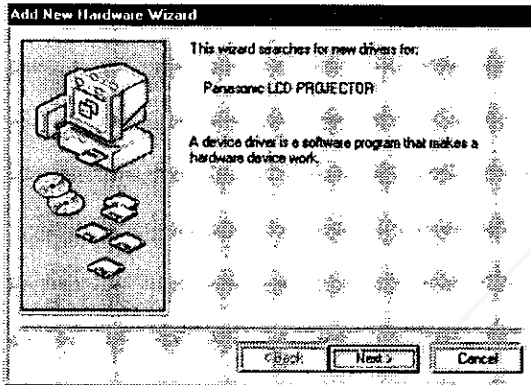

### Note

- If you click “Cancel”, the “new hardware wizard” launches each time your PC is connected to the projector.

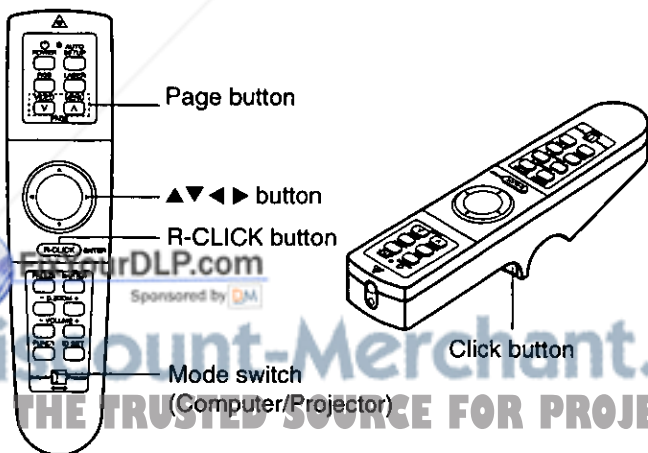

### Mode switch (Computer/Projector)

Mode switch is set to the Computer position.

#### • Page button

▲: Functions as the Page Up button on your PC keyboard.

▼: Functions as the Page Down button on your PC keyboard.

#### • Arrow (▲ ▼ ◀ ▶) button

These buttons functions as the cursor control buttons on your PC.

#### • R-CLICK button

This button functions as the right button on your PC mouse.

#### • Click button

This button functions as the left button on your PC mouse.

### Note

- The optional wireless receiver (Model ET-PMRC1) is needed for a PC not equipped with a USB port.

## ■ Using the remote control in wired mode

Two or more projectors can be controlled from a single Remote Control by connecting the Remote Control to the projectors with the accessory Wired Remote Control Cable. The wired remote control is particularly useful if the projector is sited in a place where it is exposed to intense ambient light or if an object blocks the path of IR light from the Remote Control.

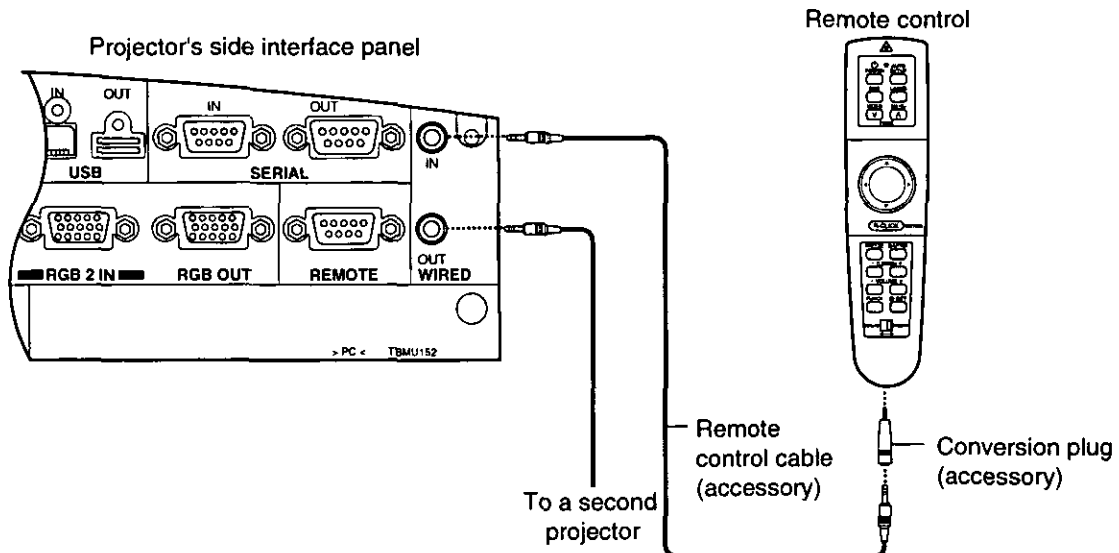

# Setting-up

## ■ Projection Schemes

Any of the following four projection schemes can be used with the PT-L6500U/L6600U projector depending on user's needs or viewing conditions. Use "OPTION 1" menu (chosen from the MAIN MENU) to choose the appropriate projection scheme (see page 34).

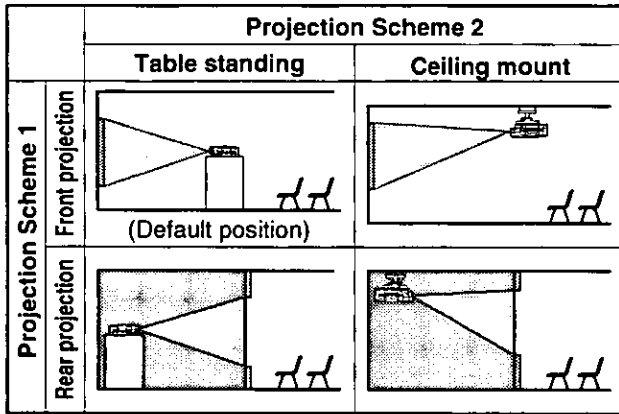

## ■ Installation Geometry

After the projector is roughly positioned, picture size and vertical picture positioning can be finely adjusted with the powered zoom lens and lens tilt mechanism.

### Side view

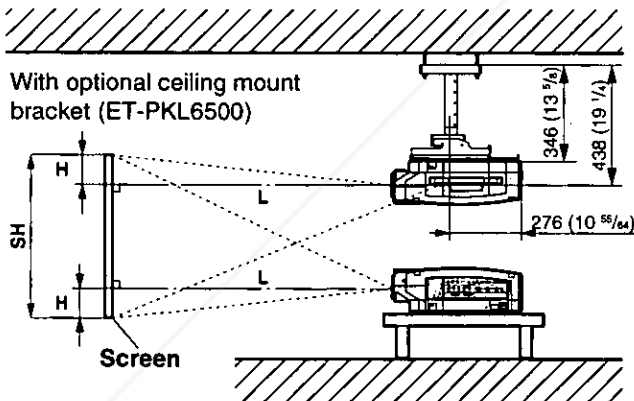

- L: Projection distance
- SH: Image height
- SW: Image width
- H: Distance from center of lens to bottom edge of projected image.

### Top view

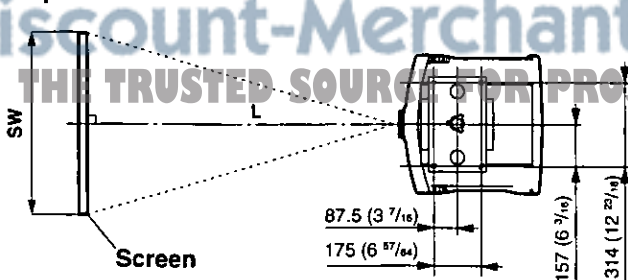

[unit : mm]

## ■ Projection Distances

Unit: m ( ): inch ( ): foot

Diagonal length	Screen Size (4 : 3)			Projection distance: L		Height position: H
	Height (SH)	Width (SW)	Wide (LW)	Telephoto (LT)		
0.76 (30")	0.46 [1'6"]	0.61 [2']	—	1.4 [4'7"]	0.02 to 0.22 (7/8 to 8 21/32)	
1.02 (40")	0.61 [2']	0.81 [2'8"]	1.4 [4'7"]	1.9 [6'2"]	0.03 to 0.30 (1 3/16 to 11 13/16)	
1.27 (50")	0.76 [2'6"]	1.02 [3'4"]	1.8 [5'11"]	2.4 [7'11"]	0.04 to 0.38 (1 9/16 to 14 61/64)	
1.52 (60")	0.91 [3']	1.22 [4']	2.1 [6'11"]	2.9 [9'6"]	0.05 to 0.45 (1 49/64 to 17 23/32)	
2.03 (80")	1.22 [4']	1.63 [5'4"]	2.9 [9'6"]	3.9 [12'10"]	0.06 to 0.60 (2 23/64 to 23 10/16)	
2.54 (100")	1.52 [5']	2.03 [6'8"]	3.6 [11'10"]	4.9 [16'8"]	0.08 to 0.76 (2 63/64 to 29 69/64)	
3.05 (120")	1.83 [6']	2.44 [8']	4.3 [14'1"]	5.9 [19'5"]	0.09 to 0.91 (3 37/64 to 35 63/64)	
3.56 (140")	2.13 [7']	2.84 [9'4"]	5.1 [16'8"]	6.9 [22'7"]	0.11 to 1.06 (4 15/64 to 43 47/64)	
4.06 (160")	2.44 [8']	3.25 [10'8"]	5.8 [19']	7.9 [25'11"]	0.12 to 1.21 (4 49/64 to 47 41/64)	
4.57 (180")	2.75 [9']	3.66 [12']	6.6 [21'8"]	8.9 [29'2"]	0.14 to 1.37 (5 25/64 to 53 15/16)	
5.08 (200")	3.05 [10']	4.06 [13'4"]	7.3 [24']	9.9 [32'6"]	0.15 to 1.52 (5 63/64 to 59 27/32)	
5.51 (220")	3.35 [11']	4.47 [14'8"]	8.1 [24'7"]	10.9 [35'10"]	0.17 to 1.67 (6 9/16 to 65 3/4)	
6.10 (240")	3.66 [12']	4.88 [16']	8.8 [28'11"]	11.9 [39']	0.18 to 1.82 (7 11/64 to 71 21/32)	
6.60 (260")	3.96 [13']	5.28 [17'4"]	9.5 [31'2"]	12.9 [42'4"]	0.20 to 1.98 (7 51/64 to 77 61/64)	
7.11 (280")	4.27 [14']	5.69 [18'8"]	10.3 [33'10"]	13.9 [45'7"]	0.21 to 2.13 (8 29/64 to 83 55/64)	
7.62 (300")	4.57 [15']	6.10 [20']	11.0 [36'1"]	14.9 [48'11"]	0.23 to 2.28 (8 63/64 to 89 49/64)	

Setting-up dimensions which are not given in the above table can be calculated using the formulas below.

If the screen size (diagonal) is SD, then the following formulas are first used to obtain the screen width (SW).

$$SW = (SD \times 0.0254) \times 4 + 5 \quad (\text{SD unit is inches})$$

The value for SW obtained above can then be used with the following function to calculate the projection distance for the wide lens position (LW) and the projection distance for the telephoto lens position (LT).

$$LW = 1.831 \times SW - 0.071$$

$$LW = 2.449 \times SW - 0.066$$

For 16 : 9 aspect ratios, the following formula can be used to calculate the screen width (SW).

$$SW = (SD \times 0.0254) \times 16 + \sqrt{327}$$

### Note

- The dimensions in the table above and the values obtained from the above formulas may contain slight errors.
- It is recommended that you use the projection distance for the wide lens position (except in cases where the diagonal picture size is 0.762 m [30"]).
- The above dimensions are the case when the aspect ratio is 4:3. When an SXGA signal is input and projected, the right and left ends of the picture will be blanked the aspect ratio will be 5:4.

## ■ Setup precautions

- Before connecting any of your video/audio equipment to the projector, carefully read the owners manual supplied with the equipment once again.
- All cable connections should be made with the entire system devices, including the projector, first turned off.
- Obtain commercial interconnecting cables for devices supplied with no accessory or optional interconnect cables.
- Video signals containing too much jitter may cause the images on the screen to randomly wobble or shake. Inserting a time base corrector (TBC) in the projector's video line will relieve this problem.
- The projector only accepts composite-video, S-video, analog-RGB (with TTL sync. level), and digital signal from PC.
- The projector contains built-in speakers. When greater sound output is required, use an audio amplifier connected to the projector's AUDIO OUT jack. Once the cable is plugged into the AUDIO OUT jack, the audio signal lines to the internal speakers are automatically cut off.
- Some PC models are not compatible with the PT-L6500U/L6600U projector.

• The pin assignments on the S-VIDEO IN port are as follows:

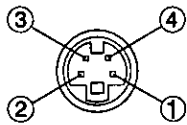

Viewed from mating side

Pin No.	Signal
①	Ground (luminance)
②	Ground (color)
③	Luminance signal
④	Color signal

• The pin assignments on the DVI-D input port are as follows (interface with TMDS port on PC):

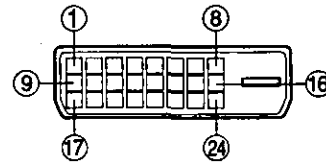

Viewed from mating side

Pin No.	Signal	Pin No.	Signal
①	T. M. D. S data 2-	⑬	T. M. D. S data 3+
②	T. M. D. S data 2+	⑭	+5 V
③	T. M. D. S data 2/4 shield	⑮	Ground
		⑯	Hot plug sense
④	T. M. D. S data 4-	⑰	T. M. D. S data 0-
⑤	T. M. D. S data 4+	⑱	T. M. D. S data 0+
⑥	DDC clock	⑲	T. M. D. S data 0/5 shield
⑦	DDC data		
⑧	—	⑳	T. M. D. S data 5-
⑨	T. M. D. S data 1-	㉑	T. M. D. S data 5+
⑩	T. M. D. S data 1+	㉒	T. M. D. S clock shield
⑪	T. M. D. S data 1/3 shield		
⑫	T. M. D. S data 3-	㉓	T. M. D. S clock+
		㉔	T. M. D. S clock-

• The pin assignments on the RGB2 input port are as follows:

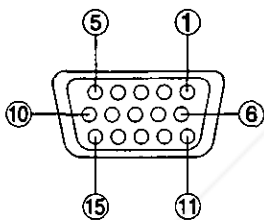

Viewed from mating side

Pin No.	Signal
①	R/Pr
②	G/G · SYNC/Y
③	Pb
⑫	SDA
⑬	HD/SYNC
⑭	VD
⑮	SCL

Pin ⑨: Not used.

Pins ④-⑧, ⑩, and ⑪: Ground.

Pins ⑫ and ⑮: Valid if the PC has the corresponding function.

# Setting-up

## ■ Example of connecting with AV products

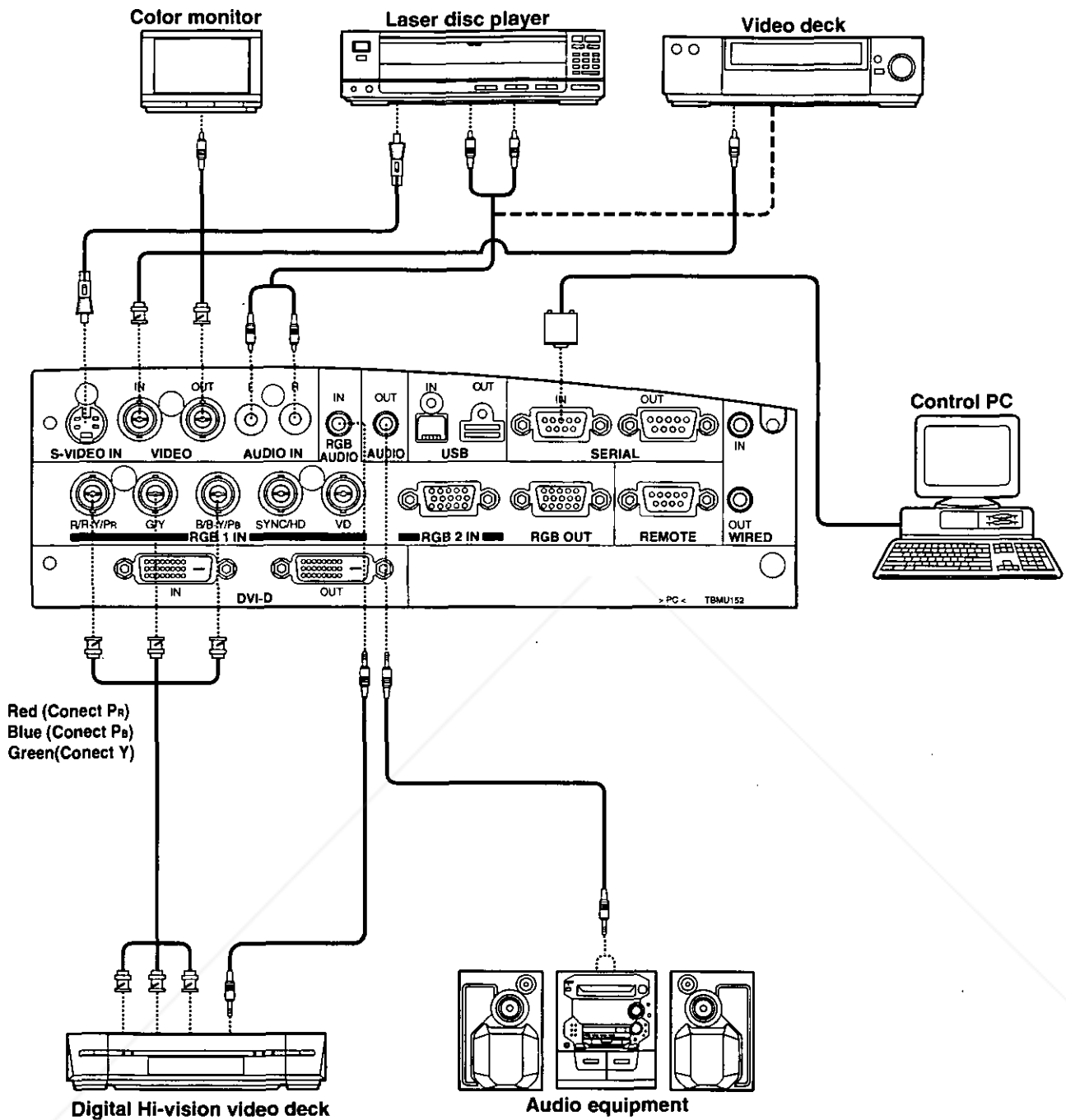

### Note

- Only a single pair of audio inputs (AUDIO IN L-R) is available for the composite and S video, also only a signal RGB audio input is available for the RGB1, RGB2 and DVI-D. You will need to change audio input connections depending on your signal selection.
- If your audio equipment is connected to the projector's AUDIO OUT jack, the remote control supplied with the projector can be used to control volume, balance, and mute on the audio output line.

## ■ Example of connecting with PCs

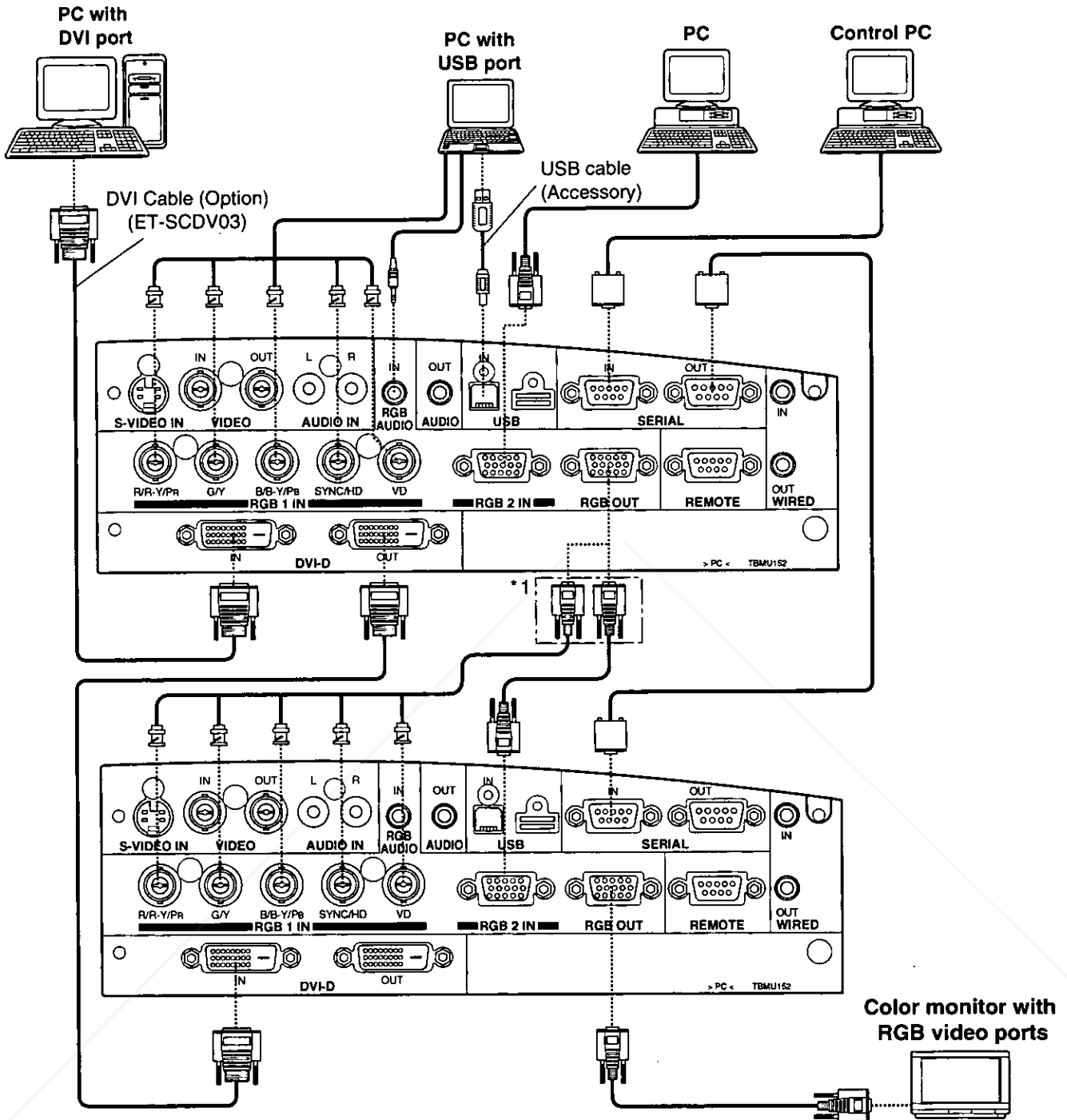

### Caution

- When the projector's main power is turned OFF, also turn OFF all the PCs connected to it.
- \*1 An asterisk denotes that the second projector requires positioning if the RGB outputs are connected in a daisy chain. However, the signals should be divided at the signal source if possible.

### Note

- If your PC is not equipped with a USB port, a ET-RMRC1 interface will be needed to use the mouse capability of the remote control.
- For the specifications of the RGB signals that can be applied from the PC, see the data sheet on page 48.
- If your PC has the resume feature, the computer may not function properly until the resume capability is disabled.
- Signals applied to the RGB1 or RGB2 ports appear at the RGB OUT port.

# Setting-up

## ■ Example of connecting with system switcher

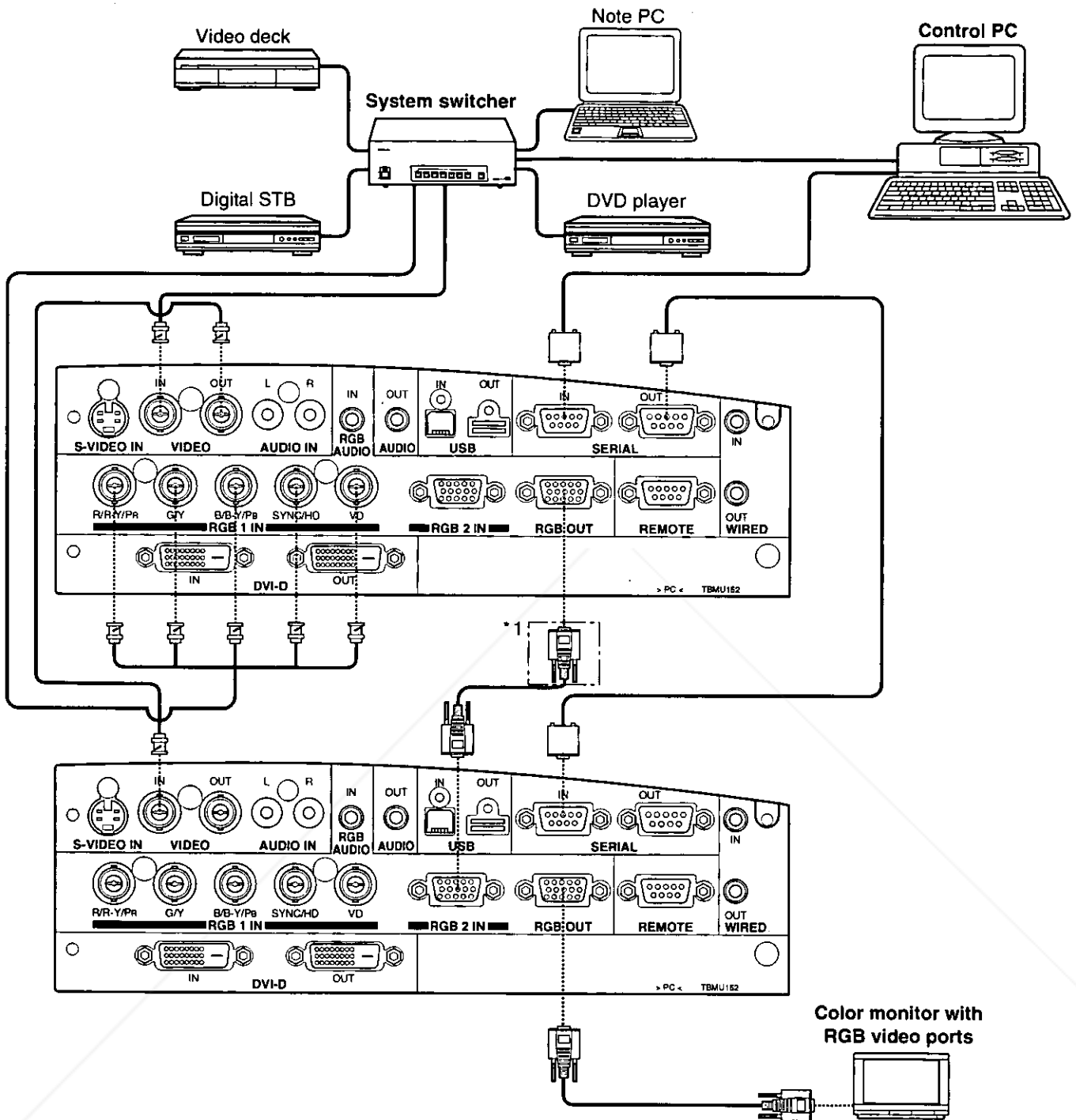

Color monitor with RGB video ports



### Caution

- \*1 An asterisk denotes that the second projector requires positioning if the RGB outputs are connected in a daisy chain. However, the signals should be divided at the signal source if possible.

### Note

- Read the operating instructions for the system switcher carefully.

# Starting to use

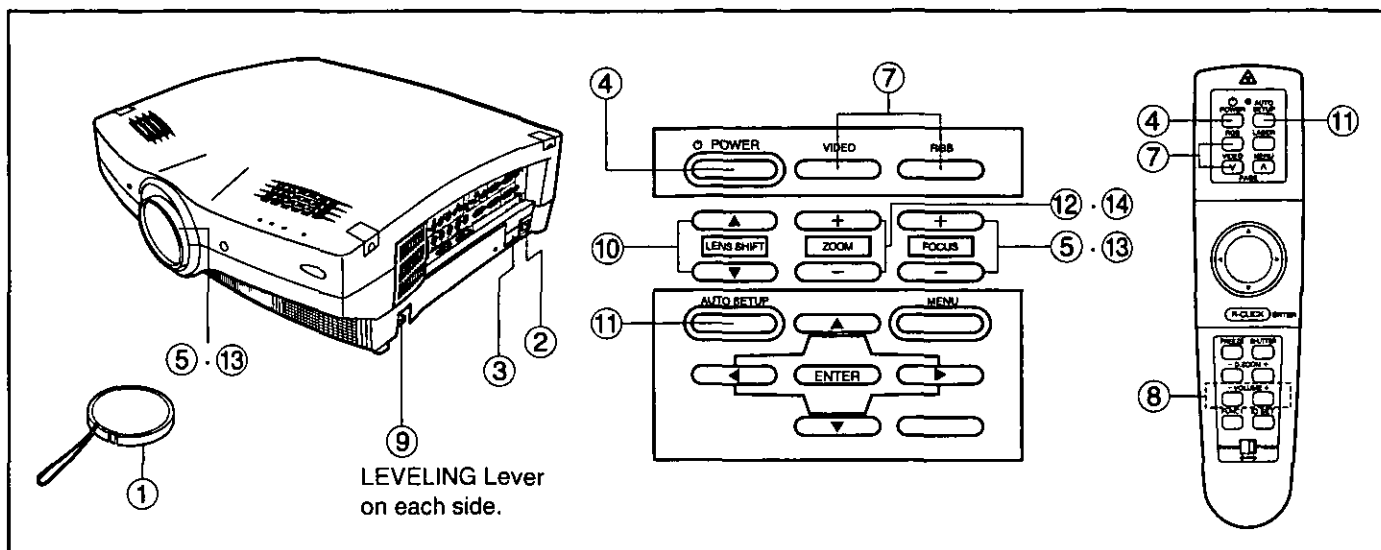

## ■ Powering Up the Projector

- ① Remove the lens cover.
- ② Plug one end of the accessory power cord into the projector's power receptacle, and the other end to a convenient wall outlet. (AC 100-120 V 50Hz/60 Hz)
- ③ Press the "I" marked side of the MAIN POWER switch.  
The projector will enter standby mode, with the power status light lit in red.
- ④ Press the "POWER" button on the projector or "POWER" button on the remote control.  
The power indicator on the projector will flash orange. After a short period, the indicator will illuminate green.

## ■ Making Initial Adjustment / Setting input port

- ⑤ Roughly adjust the focus with the "FOCUS (+/-)" buttons on the rear control panel or with focus ring on the projection lens.
- ⑥ Choose the projection scheme (page 34).
- ⑦ Select the input port with the "RGB" or "VIDEO" button. — [Projector or remote control]

RGB	RGB1(YPbPr1) → RGB2(YPbPr2) → DVI
VIDEO	S-VIDEO ↔ VIDEO

- ⑧ Adjust volume level with the "VOLUME (+/-)" buttons. — [Remote control]  
For volume level control on the projector, see page 27. If your audio equipment is connected to the AUDIO OUT jack, the VOLUME control adjusts the line output level.
- ⑨ Adjust the projector's tilt angle (page 24).
- ⑩ Adjust the vertical position of the picture (page 24)
- ⑪ Press the "AUTO SETUP" button — [Projector or remote control]

- ⑫ Fit the picture size to the screen size— [Projector]  
Fit the picture size to the screen size with the "ZOOM (+/-)" buttons on the projector's rear control panel. Repeat steps ⑨ through ⑫ until the picture completely fits within the screen bounds.
- ⑬ Adjust focus again with the "FOCUS (+/-)" buttons on the rear control panel or with the focus ring on the projection lens.
- ⑭ Adjust the "ZOOM (+/-)" buttons again until the picture completely fits within the screen bounds.

## ■ Powering Off the Projector

1. Press and hold the "POWER" button for more than 0.5 seconds or quickly double-press the button. The projection lamp will turn off, with the power status light turned to orange.
2. Wait until the power status light turns to red (i.e., until the cooling fan stops). While the cooling fan is still running, never switch the MAIN POWER switch OFF, unplug the projector from the outlet, or open the main circuit breaker.
3. Press the "O" marked side of the MAIN POWER switch to remove all power from the projector.

### Note

- If the projector is re-powered while the projection lamps are cooling down after the last power off, the lamps will remain off for a short time before they automatically turn on again (Power Status light flashing in orange).
- The projector consumes approx. 9 Watts of power in Standby mode after the cooling fan stops (Power Status light lit in red).
- If you inadvertently shut off the Main Power switch, the projection lamp may remain off for some time on re-powering the projector. The lamp will automatically turn on after a period of time (Power Status light lit in green).



# Starting to use

## ■ Leveling the Projector

For the best viewing result free from distortion, the projector should be carefully leveled on its base. Follow the steps below to correct the tilt angle of the projector when it is installed on a floor-standing base.

1. While lifting and holding the front side of the projector to the level position, pull and hold the **LEVELING** button on each side of the bottom panel until the leveling feet rest on the projector base surface.

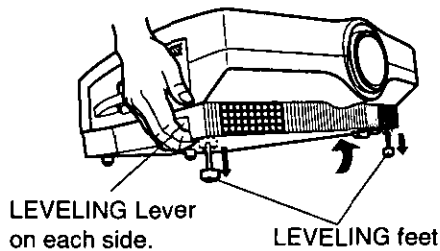

### Caution

- Keep holding the projector until both leveling feet touch the base surface.

2. Release the **LEVELING** levers.

The leveling feet lock in place.

3. Make fine leveling adjustments by manually turning the leveling feet.

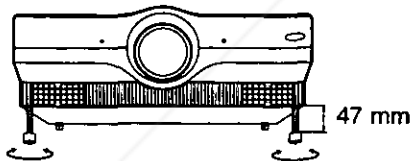

### Note

- The maximum length of the leveling foot is 47 mm. If it is rotated on reaching that length it will turn freely without extending further.
- If the picture has keystone distortion, do keystone adjustment from the menu. (page 32)

## <Retracting the Leveling Feet>

While lifting the front side of the projector, raise the Leveling lever, and then slowly lower the unit.

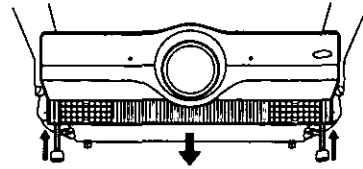

### Caution

- Do not press the **LEVELING** levers without holding the projector with your hands. Otherwise, the leveling feet will be unlocked and the projector may drop rapidly onto the projector base surface, possibly leading to damage.

## ■ Adjusting the Vertical Position of the Picture

The vertical position of the picture can be adjusted using the electric "LENS SHIFT" buttons on the rear control panel. Do this adjustment after the projection distance and projector position have been determined.

- Adjusting vertical position with the "LENS SHIFT" buttons:

Press the ▲ button to shift the picture upward.

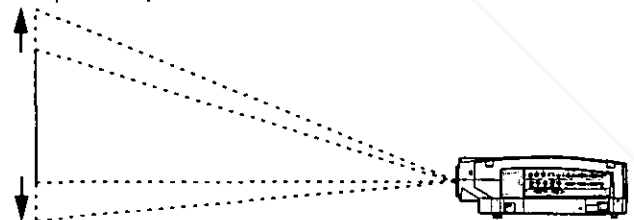

Press the ▼ button to shift the picture downward.

- Adjusting vertical position from the menu:

Alternatively, you can adjust the vertical position of the picture by choosing the "LENS SHIFT" option from the "OPTION 1" menu chosen from the MAIN MENU (see page 34).

## Caution

When shifting the lens, be careful not to catch your fingers between the lens and shroud.

## ■ Advice on the installation of exhaust guides

Hot air from the cooling fan vents may in rare cases cause disturbances to the screen image. If this should occur, install the attached exhaust guides.

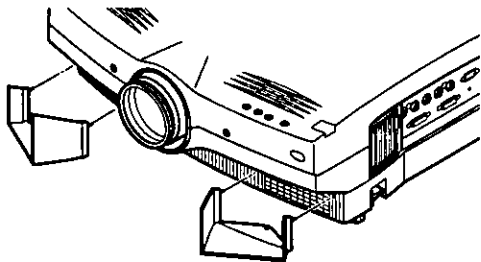
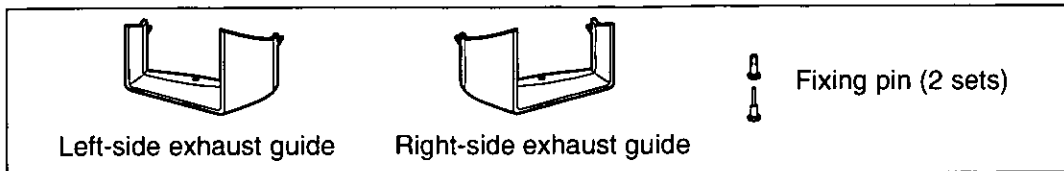

1. Identify the left-side and right-side exhaust guides, then insert the tabs of the relevant guide into the holes on the front of the projector.

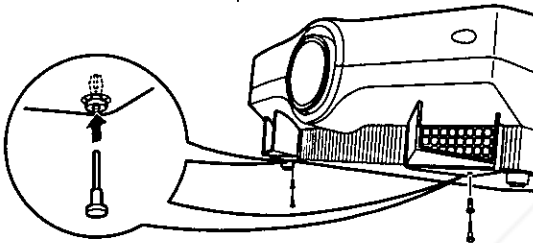

2. Insert the fixing pins from the bottom of the projector and tighten them securely.

## Using the Freeze function

The picture freezes each time you press the remote control "FREEZE" button.

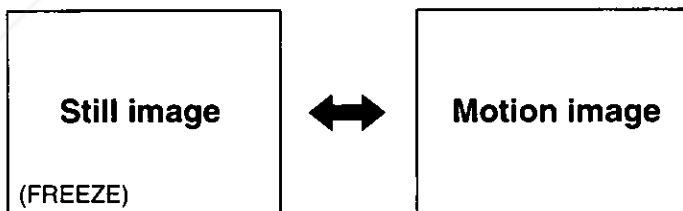

## Using the Shutter function

The shutter function can be used to momentarily turn off the picture and sound from the projector when the projector is not being used for short periods of time, such as during breaks in meetings or when carrying out preparation. The projector uses less power in shutter mode than it does in normal projection mode.

1. Press the remote control/ "SHUTTER" button to mute both picture and sound.

Both video and audio are turned off.

2. To clear muting, press any button on the remote control or projector.

Appear the picture and sound.

# Using the Digital Zoom (D.ZOOM +/-) function

A specific portion of the picture presently on the screen can be zoomed in on with the remote control/ "D.ZOOM (+/-)" buttons. You may find it useful for highlighting a specific object during your presentation.

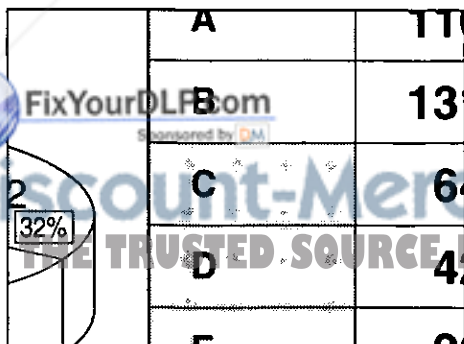
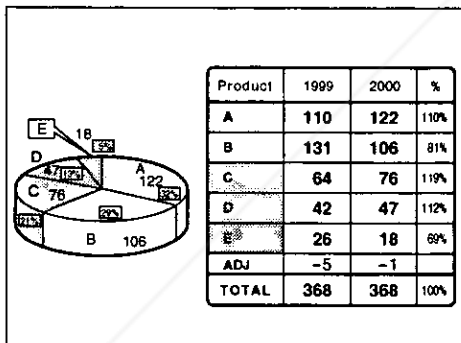
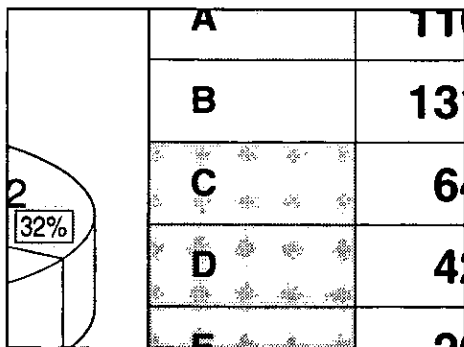
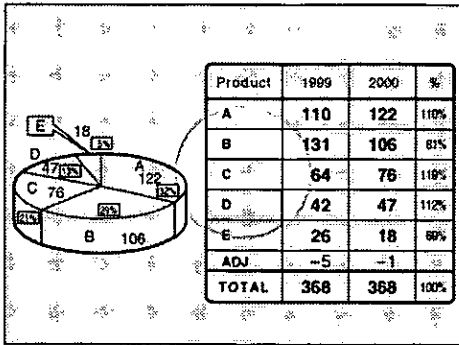

## < For PT-L6500U >

### 1. Press the remote control Digital Zoom (D.ZOOM +/-) buttons.

The projector enters Highlight mode as illustrated on the left.

### 2. Use the arrow (▲ ▼ ◀ ▶) buttons to highlight the portion you wish to zoom in on.

### 3. Press the "ENTER" button.

The highlighted portion will now be enlarged 2.0 times to the size of the full screen.

### 4. Change the magnification with the "D.ZOOM (+/-)" buttons.

RGB signal input : Over the range of 1.0 to 3.0 times in 0.1 steps.

Video signal input : Over the range of 1.0 to 2.0 times.

### 5. To restore the original image, press the "MENU" button.

Pressing the "MENU" button will not return the screen to Highlight mode. To return to Highlight mode, temporarily exit Zoom mode, then press the "D.ZOOM (+/-)" button again.

## < For PT-L6600U >

### 1. Press the Remote Control/ "D.ZOOM +/-" button.

The center portion of the picture will be magnified.

### 2. Change magnification with the "D.ZOOM +/-" button:

Magnification can be changed from 1.0 to 3.0 times for RGB, and 1.0 to 2.0 times for composite or S-video, all in 0.1 steps.

### 3. The enlarged portion of the picture can be shifted with the ▲, ▼, ◀, or ▶ buttons.

The highlighted portion will now be enlarged 2.0 times to the size of the full screen.

### 4. Press the "MENU" button to return to the normal picture.

## Caution

- If the input video signal format is changed while in Zoom mode, the projector will exit Zoom mode.
- PT-L6600U does not have a highlight indication.

# On-screen menus

## ■ Menu screens

Menus are extensively used for configuring, adjusting, or reconfiguring the projector. The menu structure is as follows:

### MAIN MENU (PT-L6500U)

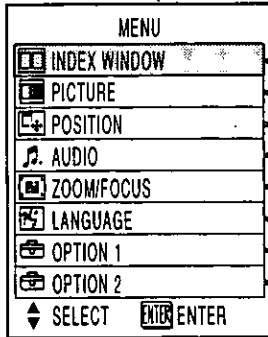

**Note** • PT-L6600U does not have "INDEX WINDOW" function.

### OPTION 2 (Pages 35 and 36)

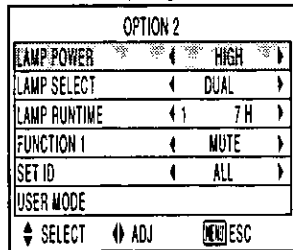

### OPTION 1 (Page 34)

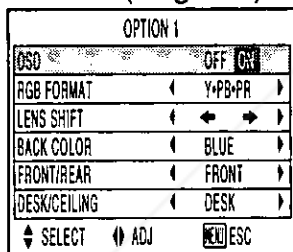

### LANGUAGE (Page 33)

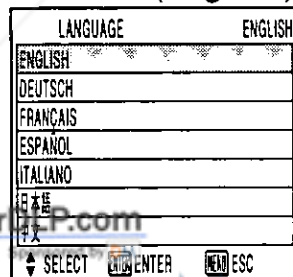

### ZOOM/FOCUS (Page 33)

### VOLUME ADJUSTMENT

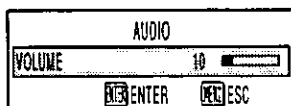

Press the "ENTER" button, and then press the ◀ and ▶ buttons to adjust the volume level.

### INDEX WINDOW FUNCTION (Page 29)

### PICTURE (Pages 30 and 31)

When on RGB/YPbPr/DVI signal is being input

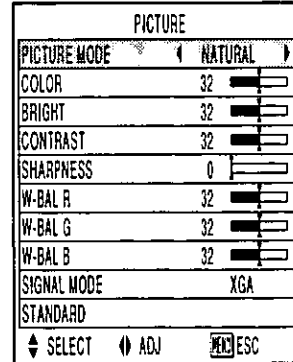

When on S Video/Video signal is being input

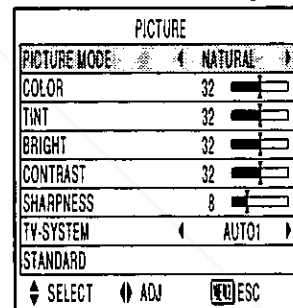

### POSITION (Pages 32 and 33)

When on RGB/YPbPr signal is being input

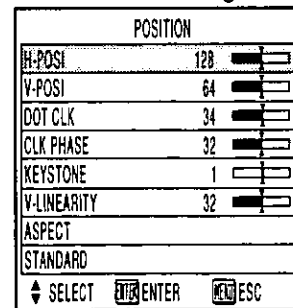

When on S Video/Video signal is being input

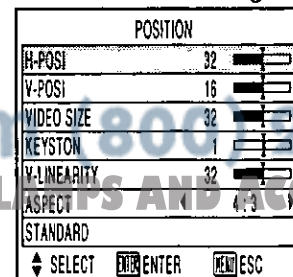

# On-screen menus

## Basic Menu Operations

### 1. Press the "MENU" button.

The MAIN MENU appears on the screen.  
(e.g. : MAIN MENU for the PT-L6500U)

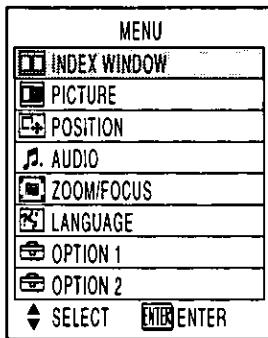

### 2. Select (highlight) the desired item with the ▲ or ▼ buttons.

Selected items are displayed in yellow.

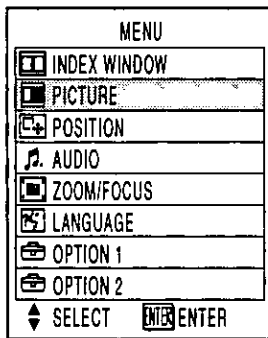

### 3. Press the "ENTER" button to enter your selection.

The submenu for the selected option will now open.  
(e.g. : PICTURE Menu)

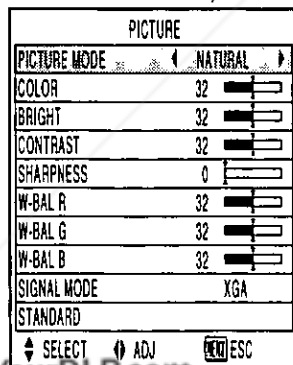

Highlight the desired adjustment item with the ▲ or ▼ buttons, then change the parameter value with the ◀ or ▶ buttons. An individual bar graph as shown in the following figure is displayed for each adjustment item.

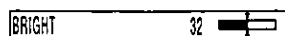

- If no button is operated for approx. 5 seconds while a bar graph is displayed, the screen will return to the previous page.

## Returning to the Previous Page

- Pressing the "MENU" button returns the screen to the previous menu page.
- When the MAIN MENU is on the screen, pressing the "MENU" button clears all menus from the screen.

## Menu Items Shown with White Characters

- Some menu items may not be valid for some signal formats applied to the projector. Invalid menu items are shown in white letters and the "ENTER" button remains ineffective to those items.

## Menu Items Setting

The bottom prompt line differs on each menu depending on the selected menu option:

- The prompt "◀ ▶ ADJ" is displayed for direct adjustment.
- The prompt "ENTER ENTER" appears for a separate bar graph.

## Reset the Factory Default

If the "STANDARD" option in the "PICTURE" or "POSITION" menus is chosen, or the "STANDARD" option in the remote control's "FUNC1" button menu is chosen, all the parameter values in the menu are reset to the factory default.

- Default Setting in Menu

When all the parameter values in the menu are reset to the factory default, a "STD" indicator appears on the upper right corner of the menu.

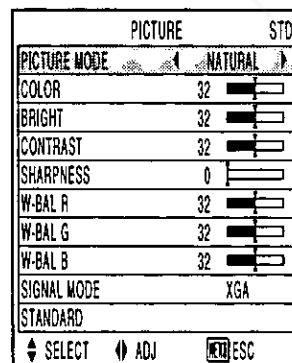

- Default Setting on Bar Graph

If the parameter value on a bar graph is reset to the factory default, the bar turns to green.



### Note

- The upper and lower triangular markings on a bar graph indicate the default setting for the parameter. If no such triangular markings are shown on the bar graph, the parameter cannot be reset to the factory default.

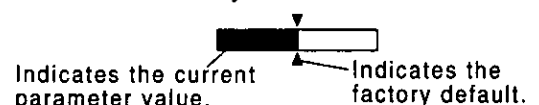

# Using the INDEX WINDOW function (PT-L6500U only)

The picture presently on the screen can be saved to memory as a still image. The saved image can then be shown alongside a moving image in a split screen (index window).

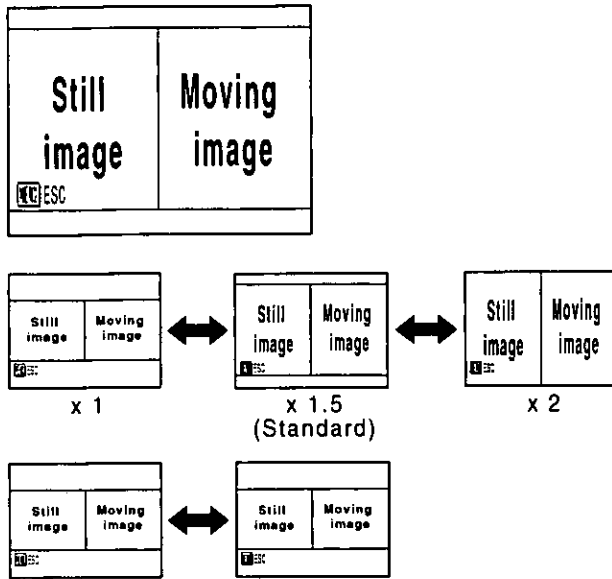

## Note

- The aspect ratio of each half of the split screen is 2:3, with the image height extended by 1.5 times the normal height by default.

1. Select the “INDEX WINDOW” from menu and press the “ENTER” button.
2. Change the picture height with the ▲ or ▼ button.
  - The picture height can be changed at a magnification of x1, x1.5, or x2.0 times.
3. The still and motion images can be swapped with the ◀ or ▶ button.
4. Press the “ENTER” button to save the split screen image to memory as an index window image.

## Caution

- As you change the screen size, the aspect ratio of the picture also changes. Carefully read the caution for S1 signals on page 33 before changing the screen size.

## Note

- When you execute steps 2 and 3 above, the memory is temporarily cleared and the index window image is saved to memory.
- If the input signal format is changed while an index window is on the screen, the projector will exit the index window mode.

# Adjusting the picture

1. Obtain the MENU window and select (highlight) the desired option item with the ▲ or ▼ buttons.
2. Adjust the parameter value with the ◀ or ▶ buttons. For items requiring a separate bar graph, first display the bar graph with the "ENTER" or ◀ / ▶ buttons, then adjust the parameter value with the ◀ or ▶ buttons.

• For RGB/YPbPr/DVI signals

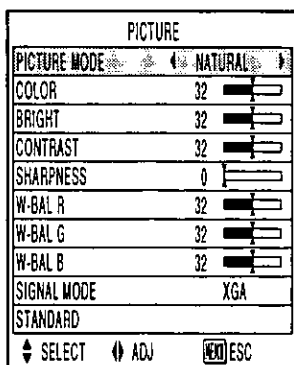

• For composite or S-video signals

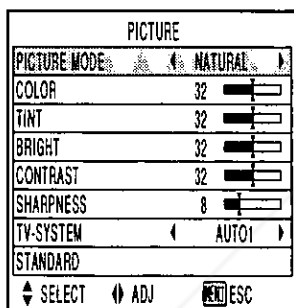

## PICTURE MODE

The picture mode can be selected from the following depending on viewing conditions and the video signal source in use:

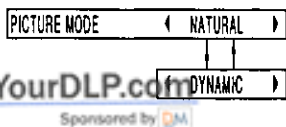

**NATURAL:** Picture brightness/contrast ratio is adjusted to that suitable for projection image viewing under typical location conditions.

**DYNAMIC:** Picture brightness/contrast ratio is increased to suit brighter viewing environments.

## COLOR

(Valid for composite/S-video/YPbPr signals only)

- ▶ button: Deepens colors.
- ◀ button: Weakens colors.

## TINT

(Valid for NTSC / NTSC4.43 standard)

"TINT" is used to adjust human skin.

- ▶ button: Adjusts skin tone toward greenish color.
- ◀ button: Adjusts skin tone toward reddish-purple.

### Note

- PT-L6600U is able to adjust the tint level at YPbPr input mode.

## BRIGHT

"BRIGHT" is used to adjust the black level (brightness).

- ▶ button: Raises the picture brightness.
- ◀ button: Lowers the picture brightness.

## CONTRAST

"CONTRAST" is used to adjust the contrast ratio.

- ▶ button: Raises the contrast ratio.
- ◀ button: Lowers the contrast ratio.

## SHARPNESS

(Valid for composite/RGB/YPbPr signals only for PT-L6500U)

(Valid for composite/YPbPr signals only for PT-L6600U)

"SHARPNESS" is used to adjust the crispness of the image.

- ▶ button: Sharpens the edge of the image.
- ◀ button: Softens the edge of the image.



FixYourDLP.com

Sponsored by DM

Discworld.com (800) 281-8860  
THE TRUSTED SOURCE FOR PROJECTOR LAMPS AND ACCESSORIES

## ■ TV-SYSTEM

(for composite/S-video only)

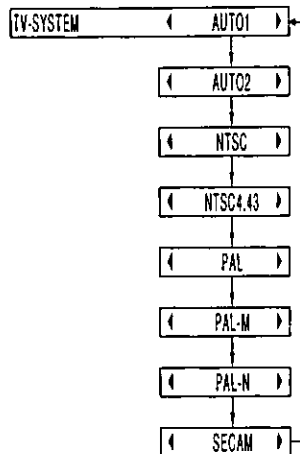

**AUTO1:** Automatically selects the TV standard that matches the input video signal, out of NTSC, PAL, NTSC4.43, and SECAM.

**AUTO2:** Automatically selects the TV standard that matches the input video signal, out of NTSC, PAL-M, and PAL-N.

- Normally "AUTO1" or "AUTO2" should be chosen for this option.
- If input video signal quality is poor, choose the TV system that matches the input video signal.

Automatically selected by detecting the horizontal/vertical scan frequencies and color sub-carrier listed in the table below:

Table	H. Scan Frequency (kHz)	V. Scan Frequency (Hz)	Color Subcarrier (MHz)
NTSC	15.75	60.00	3.58
NTSC4.43	15.75	60.00	4.43
PAL	15.63	50.00	
PAL-M	15.75	60.00	3.58
PAL-N	15.63	50.00	
SECAM	15.63	50.00	4.25 or 4.41

## ■ W.BAL (White balance) R/G/B

(for RGB/DVI signals only)

White balance may be adjusted for each color to correct reddish or bluish tones in white portions of the picture:

- ▶ button: Deepens the selected color.
- ◀ button: Weakens the selected color.

### Note

- Separate sets of adjustment parameters can be saved for the RGB1, RGB2 and DVI inputs.

## ■ SIGNAL MODE

(for RGB/YPbPr/DVI signals only)

"SIGNAL MODE" displays the names of the signals (resolution) presently applied to the RGB or YPbPr input ports. For details of signal names, see the table on page 48.

If the user mode is registered, the following menu will appear. You can choose either "AUTO" or a registered user setting from "USER1" to "USER3" with the ◀ or ▶ buttons.

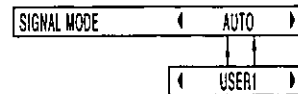

If "AUTO" is chosen, a setting closest to the user setting is automatically selected. (In the example above, only "USER1" is registered for user address.)

### Note

- If you choose a user address registered for a signal that does not match the input signal, it is regarded as no signal, and the projector will display the specified background color.

## ■ STANDARD

Pressing the "ENTER" button resets all the adjustment parameter values to the factory default values, with a "STANDARD" indicator shown on the upper right corner of the menu.



# Adjusting the position

1. Obtain MENU window and move highlight cursor up and down through the menu with the ▲ or ▼ button.
2. Adjust parameter value for the selected item with the ◀ or ▶ button. For items that call for a separate bar graph, first show the bar graph with the "ENTER" or ◀ / ▶ button, then adjust parameter value with the ◀ or ▶ button.

• For RGB/YPbPr/DVI signals

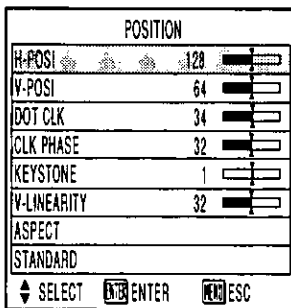

• For composite or S-video signals

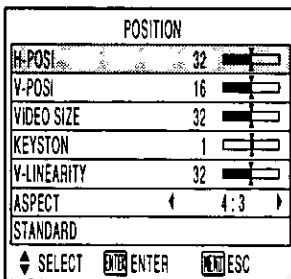

## ■ HORIZONTAL POSITION (H.POSI)

- ▶ button: Shifts the picture to the right.
- ◀ button: Shifts the picture to the left.

## ■ VERTICAL POSITION (V.POSI)

- ▶ button: Shifts the picture upward.
- ◀ button: Shifts the picture downward.

## ■ VIDEO SIZE

(Valid for composite video/S-video only)

- ▶ button: Increases picture size.
- ◀ button: Reduces picture size.

## ■ DOT CLK

(Valid for RGB signals only)

Fine, regular patterns on the screen may be disturbed by fine stripe noise called moire. Dot clock adjustment allows the user to minimize this moire.

## ■ CLK PHASE (for RGB signals only)

Adjust clock phase after you are finished with dot clock adjustment.

Clock phase adjustment allows the user to minimize visible noise with the ◀ or ▶ button.

### Note

- A noise may not disappear when adjusting the dot clock or clock phase at UXGA signal mode.
- Clock phase is adjustable for each of R, G, and B signals. Final parameter values are saved to memory.
- Clock phase adjustment is not available for digital RGB signals.

## ■ KEYSTONE

(Valid for composite video/S-video/RGB signals only)

Keystone distortion can be corrected only along either horizontal bound of the picture:

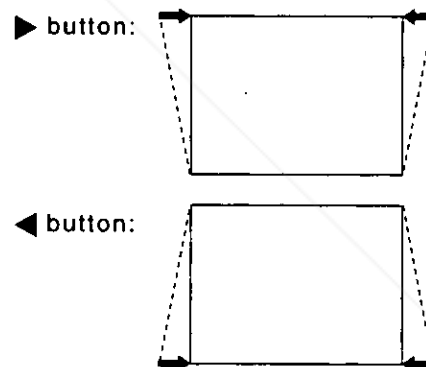

### Note

- Keystone distortion can be corrected to  $\pm 20^\circ$  of the angle of tilt for the projector. However, the greater the correction amount, the more the picture quality will deteriorate, and the harder it will become to achieve a good level of focus. To obtain the best picture quality, set up the projector and screen in such a way that the amount of keystone correction required is as minimal as possible.
- The picture size will also change when correction of keystone distortion is carried out.

## ■ V. LINEARITY

After you are finished with keystone adjustment, adjust vertical linearity with the ◀ or ▶ button. Vertical linearity is not adjustable if no correction was made to keystone distortion.

# Adjusting the Zoom/Focus

## ■ ASPECT

Aspect ratio is adjustable only for composite video, S-video, or YPbPr signals complying with the NTSC (480 i or 480 p) or PAL (625 i) standards.

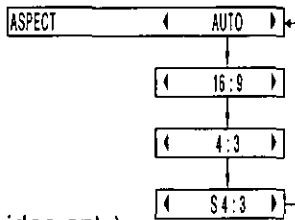

[AUTO]: (S-video only)

If an S1 video signal is applied to the S-VIDEO port, the picture is automatically switched to the 16:9 aspect ratio.

[16:9]: The image is vertically compressed into a 16:9 ratio.

[4:3]: The aspect ratio inherent to the input video signal is left intact when projected onto the screen.

[S4:3]: Picture size is compressed to 75% of the original picture size when projected. (This mode is useful when viewing pictures with the standard 4:3 aspect ratio on a wide screen with the 16:9 aspect ratio.)

### What Is S1 Video?

- The S1 video is the wide-aspect-ready S-video format containing an aspect sense signal for squeezed videos fed from video equipment.
- If "AUTO" is chosen, the projector automatically compresses the squeezed input video into the 16:9 aspect ratio if it detects the aspect sense signal.

### Caution

- If you choose an aspect ratio that does not match the source video's aspect ratio, you will see a picture with an aspect ratio not the same as that of the original picture. Choose the appropriate aspect ratio carefully to match that of the original picture.

### Note

- If the picture size is compressed or enlarged by using the 16:9 aspect ratio when the projector is used for profitable purpose or in the presence of an audience (for example, in a coffee shop or at a hotel etc.), it may infringe the rights of the copyright owner of the original picture.
- If a picture with the standard (4:3) aspect ratio is projected at a wide aspect ratio, parts of the picture may run over the screen bounds or the overall picture may be distorted. To view the picture at its original aspect ratio, choose the standard 4:3 aspect ratio.

## ■ STANDARD

Pressing the "ENTER" button resets parameter values for all the menu items to the factory default, with a "STANDARD" indicator shown in the upper right corner of the menu.

## ■ ZOOM

"ZOOM" is used to adjust projected picture size.

▶ button: Increases picture size.

◀ button: Reduces picture size.

When the picture size reaches the upper or lower limits, the color of the arrows on the four corners will change from light blue to red.

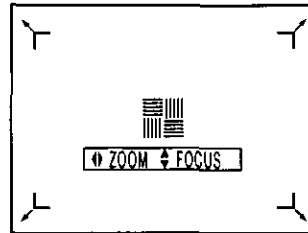

## ■ FOCUS

"FOCUS" is used to adjust picture focus with the ▲ or ▼ buttons.

# Changing the display language

1. Highlight the desired language with the ▲ or ▼ buttons (on the projector or remote control).
2. Press the "ENTER" button to enter your selection.

Menus, setting items, adjustment screens, and control button names will be displayed in the language the user chooses.

The available languages are:

English, Deutsch, Français, Español, Italiano, 中文 and 日本語.

Currently chosen language is displayed here.

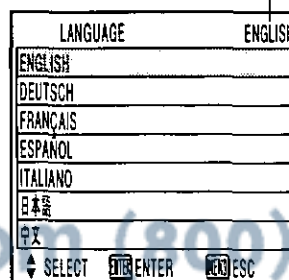

### Note

- The projector's on-screen display is set to the English language by default.

# OPTION 1 settings

1. Obtain the MENU window and select (highlight) the desired adjustment item with the ▲ or ▼ buttons (on the projector or remote control).
2. Adjust the parameter value for the selected item with the ◀ or ▶ buttons.

OPTION 1	
OSD	OFF ON
RGB FORMAT	◀ Y/PB/PR ▶
LENS SHIFT	◀ ◀ ▶ ▶
BACK COLOR	◀ BLUE ▶
FRONT/REAR	◀ FRONT ▶
DESK/CEILING	◀ DESK ▶
⬇ SELECT ⬆ ADJ	ESC ESC

## ■ OSD (On-Screen Display)

ON: The name of the signal applied is displayed in the upper left corner of the screen whenever the input signal source is switched from one to another.

OFF: The signal name is not displayed even when an input source switching occurs.

## ■ RGB FORMAT

“RGB FORMAT” is used to select the video signal format depending on the signal applied to the RGB1 or RGB2 port: Only HDTV (1080i)

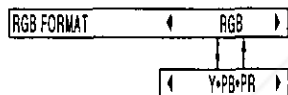

## ■ LENS SHIFT

“LENS SHIFT” is convenient for adjusting vertical picture position in situations where the projector is not easily accessible.

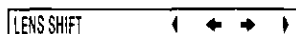

▶ button: Shifts the picture upward.

◀ button: Shifts the picture downward.

### Note

- The screen picture move reverse direction when press the ◀ or ▶ button under the ceiling set up condition.

## ■ BACK COLOR

“BACK COLOR” is used to choose the background color from blue or black when no signal is applied to the video input ports:

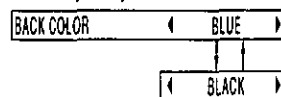

BLUE: Sets background color to blue.

BLACK: Sets background color to black.

### Note

- If a signal with unknown or unidentifiable format is applied, it will be regarded as no signal and the screen be set to the selected background color.

## ■ PROJECTION SCHEME 1

PROJECTION SCHEME 1 is used to choose the appropriate projection scheme from Front and Rear:

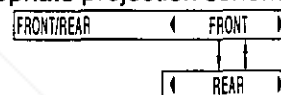

FRONT: Choose this option if pictures are projected from the front of a reflective screen.

REAR: Choose this if pictures are projected from the back of a translucent screen.

## ■ PROJECTION SCHEME 2

PROJECTION SCHEME 2 is used to choose the appropriate projection scheme from Floor and Ceiling:

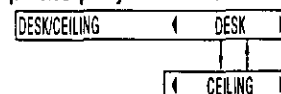

FLOOR: Choose this option if the projector is installed on a floor-standing base.

CEILING: Choose if the projector is installed on the ceiling using the optional ceiling mount bracket.

# OPTION 2 settings

1. Obtain the MENU window and select (highlight) the desired adjustment item with the ▲ or ▼ buttons (on the projector or remote control).
2. Adjust the parameter value for the selected item with the ◀ or ▶ buttons.

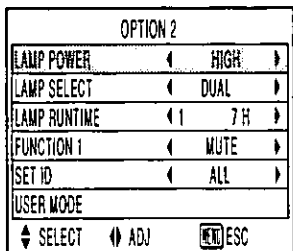

## ■ LAMP POWER

“LAMP POWER” is used to change the luminance of the projection lamp depending on user’s needs or the viewing conditions.

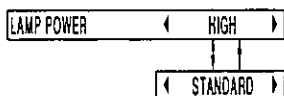

HIGH: Choose if a higher picture brightness is required.  
STANDARD: Choose for normal picture brightness.

### Note

- If it is not necessary for picture brightness to be very high (in a small meeting room, etc.), it is advisable that you set BRIGHTNESS to “STANDARD”. This will save power consumption and extend lamp life.

## ■ LAMP SELECT

“LAMP SELECT” is used to choose from Single Lamp and Dual Lamp modes depending on user’s needs or viewing conditions. In Single Lamp mode, the projector may automatically select either lamp from the 2 lamps, or the particular lamp can be specified.

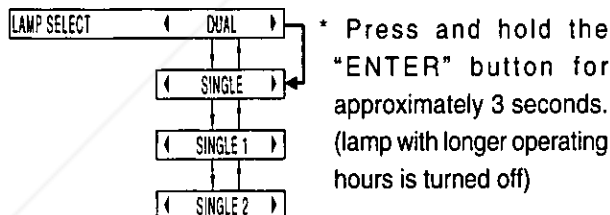

DUAL: Two lamps are used simultaneously.  
SINGLE: One of either lamps is used (lamp with shorter operating hours is automatically selected).  
SINGLE 1: Lamp Unit 1 is always used.  
SINGLE 2: Lamp Unit 2 is always used.

### Caution

- Lamp can be selected without turning off the projector.
- If lamp mode is switched from “SINGLE”, “SINGLE 1”, or “SINGLE 2” into “DUAL”, be sure to temporarily turn the projector OFF, then turn it ON again. The “DUAL” mode will become valid only after the projector is turned back ON.

### Note

- When the currently active lamp exceeds 2000 hours of cumulative operating time, if in “SINGLE1” or “SINGLE2” mode, the other lamp takes over, provided that the cumulative operating time of that lamp does not exceed 2000 hours. If the cumulative operating time of the other lamp also exceeds 2000 hours when in “Dual”, “SINGLE”, “SINGLE1”, or “SINGLE2” mode, the projector will enter Standby mode after 10 minutes.
- If only one lamp is installed in the projector, set lamp mode to either “SINGLE1” or “SINGLE2”. “SINGLE1” or “SINGLE2” is selected. If the corresponding lamp is not installed, the other lamp will turn on. The same holds for “SINGLE2” mode. If “SINGLE” mode is selected, it may take approx. 90 seconds before the lamp turns ON.

## ■ LAMP RUNTIME

“LAMP RUNTIME” is used to check the cumulative operating hours of the two projection lamps.

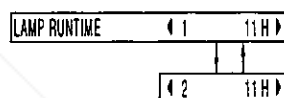

“1”: Lamp 1 operating hours is displayed.  
“2”: Lamp 2 operating hours is displayed.

### Note

- If the cumulative operating hours exceeds 1800 hours, the hour indicator flashes in red.

## ■ SETTING FUNCTION 1 [FUNC 1]

“FUNCTION 1” is used to specify the function of the remote control / “FUNC 1” button. (“FUNC 1” button functions differ between the PT-L6500U and PT-L6600U.)

- PT-L6500U

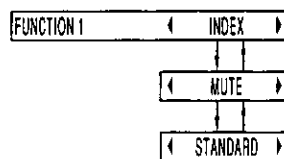

- PT-L6600U

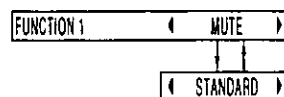

INDEX: Pressing the “FUNC 1” button displays both still and motion images on a split screen (same as the “INDEX WINDOW” option in the MAIN MENU).

MUTE: Pressing the “FUNC 1” button mutes the sound output.

STANDARD: Pressing the “FUNC 1” button resets all the parameter values now in the menu to the factory default, with a “STANDARD” indicator shown in the upper right corner of the menu.

# OPTION 2 settings

## ■ SETTING UNIT ID

UNIT ID is used to set projector IDs when the user wishes to control two or more projectors either simultaneously or separately.

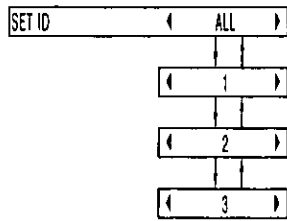

“ALL”: The projectors can be simultaneously controlled from any remote control regardless of their ID settings.

“1”: The projector can be controlled from the remote control with its projector ID set to “1”.

“2”: The projector can be controlled from the remote control with its projector ID set to “2”.

“3”: The projector can be controlled from the remote control with its projector ID set to “3”.

### Note

- Unit ID is set to “ALL” by default. Hence ID number need not be set when only one projector is used.
- If the projectors are given ID numbers, their remote controls must be assigned the same ID numbers, respectively.
- If the unit IDs of two or more projectors are set to “ALL”, the user will not be able to control them separately.
- The projector can be turned ON/OFF from the remote control only if the projector ID is set in the remote control. For the details of projector ID setting, see page 15.

## ■ Registering/Deleting/

### Displaying User Mode

(For RGB/YPbPr/DVI signals only)

Once adjustment settings are registered with User Mode, they are automatically loaded each time the projector is powered up. It is not necessary to readjust settings at every power on.

### Registering User Mode

(e.g. Registering positioning data with “USER1”)

1. Apply an input signal you want to register, and then adjust the picture position, size, and others.
2. Choose “USER MODE” on “OPTION2” and press the “ENTER” button.

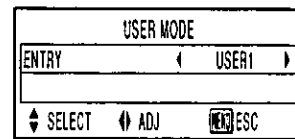

3. Choose “USER1” using the ◀ or ▶ buttons and press the “ENTER” button.

### Note

- The user address has “USER1” to “USER3”.
4. After recognizing the flashing of the “USER1” address display, press the “ENTER” button again.
  5. The above adjusted settings has been registered with “USER1”. Similarly you can also register settings with “USER2” or “USER3”.

### Deleting User Mode

(e.g. Deleting the data of USER1)

1. Choose “USER MODE” on “OPTION2” and press the “ENTER” button.
2. Choose “DELETE” using the ▲ or ▼ buttons.
3. Choose the address (“USER1”) you want to delete data from using the ◀ or ▶ buttons and press the “ENTER” button.

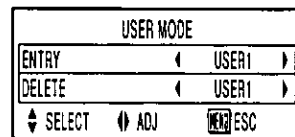

4. After recognizing the flashing of the address display, press the “ENTER” button again to delete the data of the address.

### Displaying User Mode

The User Mode can be displayed by following the steps described in “SIGNAL MODE” on page 31.

# Using the SERIAL

The projector is equipped with an RS-232C standard serial terminal at the rear. It is therefore possible to connect it to a computer for control.

## ■ Connection

### • Single

Side interface panel



D-sub 9-pin (male)

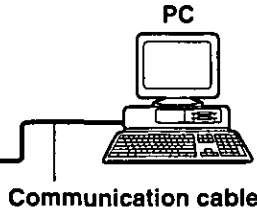

### • Plural



Communication cable

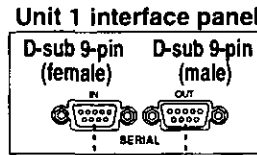

D-sub 9-pin (male)

D-sub 9-pin (female)

Communication cable

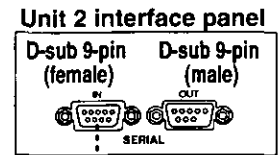

D-sub 9-pin (male)

D-sub 9-pin (female)

Communication cable

## Caution

- Purchase an appropriate communication cable to connect a computer to the serial terminal.

## ■ Pin assignments and signal names

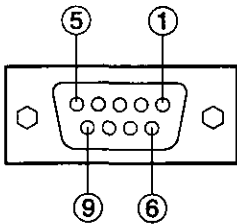

D-Sub 9-pin (female) external appearance

Pin No.	Signal name	Description
①		NC
②	TXD	Send data
③	RXD	Receive data
④		Connected internally
⑤	GND	Ground
⑥		NC
⑦	CTS	Connected internally
⑧	RTS	Connected internally
⑨		NC

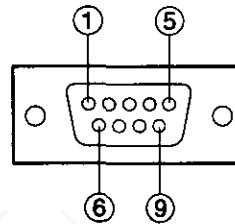

D-Sub 9-pin (male) external appearance

Pin No.	Signal name	Description
①		NC
②	RXD	Receive data
③	TXD	Send data
④		NC
⑤	GND	Ground
⑥		NC
⑦	RTS	Connected internally
⑧	CTS	Connected internally
⑨		NC

## ■ Communication requirements

Signal level	RS-232C
Sync method	Start-stop transmission
Baud rate	9 600 bps
Parity	None
Character length	8 bit
Stop bit	1 bit
X parameter	None
S parameter	None

## ■ Basic format

Transmission from the computer begins with STX, then the command, parameter and ETX are sent in this order. Colon (:) is not required when transmitting the command which does not need a parameter.

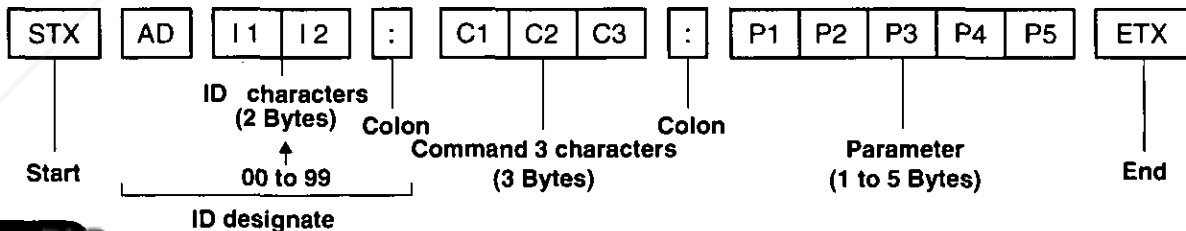

## Caution

- When transmitting several commands, wait for a response from the projector before sending the next command.
- When sending commands without parameters, a colon is not necessary.
- When it is unnecessary to designate an ID code, send the format without the part to ID designate it.

## Note

- If a wrong command is received, the projector sends ER401 back to the computer.
- When using control from the remote terminal, commands cannot be received at the serial terminal.
- Projector ID supported on the RS-232C interface is 0 (ALL) to 99.
- The remote control ID is set from 0 to 3. If a command is sent with a projector ID specified, the projector will return answer back only if the ID contained in the command matches the projector ID or the projector ID is set to ALL.

# Using the SERIAL

## ■ Control command

When controlling the projector using a computer, commands are as follows:

Command	Control contents	Remarks
PON	Power ON	During standby mode, commands other than PON are invalid. • While the lamp is ON and being controlled, the PON command is invalid. • After turning the lamp OFF, if the PON command is sent during cooling fan operation, lighting control will function for approximately 40 seconds after turning OFF to protect the lamp.
POF	Power OFF	
AVL	Volume	Parameter 000 = Adjustment value 0 ⋮ 063 = Adjustment value 63
AMT	Mute (image mute)	Parameter 0 = Mute (image mute) off      1 = Mute (image mute) on
IIS	Switch input modes	Parameter VID = VIDEO      SVD = S-VIDEO RG1 = RGB1      RG2 = RGB2      DVI = DVI
ORF	Switch RGB 1 · 2 input signals	Parameter 0 = RGB      1 = YPBPr      (Only 1080i input)
Q\$\$	Check lamp lighting condition	Parameter 0 = Standby      1 = Lamp lighting control 2 = Lamp lit      3 = Lamp off control
QLS	Check lamp lighting condition	Parameter 0 = Lamp 1 and 2 off      1 = Lamp 1 on 2 = Lamp 2 on      3 = Lamp 1 and 2 on
OSI	SET ID	Parameter 0 (ALL) to 99
OFZ	Freeze	Parameter 0 = Freeze off      1 = Freeze on
OMN	Menu	
OEN	Enter	
OCU	Cursor up	
OCD	Cursor down	
OCL	Cursor left	
OCR	Cursor right	
OAS	Auto setup	
OSH	Shutter	
DZU	D.Zoom up	
DZD	D.Zoom down	
FC1	Function 1	

## ■ Cable specifications

< Connecting to a computer >

Projector		Computer (DTE specifications)	
1	NC	NC	1
2			2
3			3
4	NC	NC	4
5			5
6	NC	NC	6
7			7
8			8
9	NC	NC	9



Discount-Merchant.com (800) 281-8860  
 THE TRUSTED SOURCE FOR PROJECTOR LAMPS AND ACCESSORIES

## ■ USB control

The same control as RS-232C can be performed using USB. Need to prepare device driver and control software.

# Using the remote terminal

Using the remote terminal built into this projector, it is possible to operate the projector from an external location from where infrared remote control signals cannot be received, by using a remote control panel.

## Example of a control panel layout

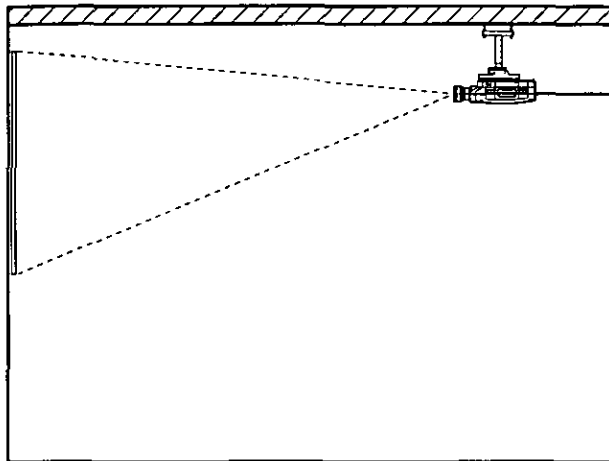

Projector set up in a meeting room

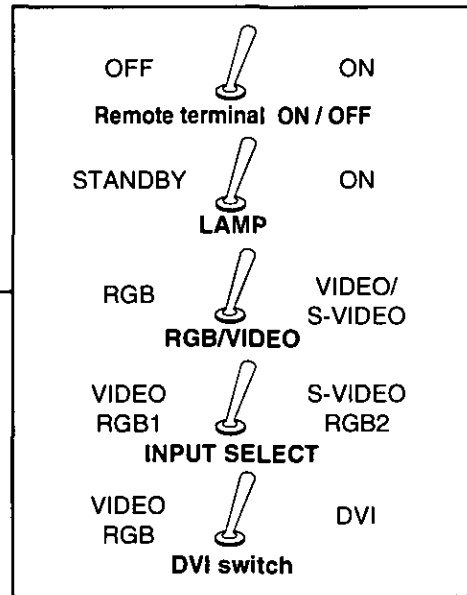

Control panel located in a different room

## Pin assignment and control

Short pin 1 and pin 9 when controlling.

D-Sub 9-pin (female) external appearance

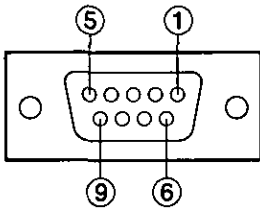

Pin No.	Name	Description	
		Short with pin ①	Open
⑨	Remote terminal ON / OFF	On	Off
②	Lamp	On	Off (standby)
③	RGB/VIDEO	VIDEO	RGB
⑤	Switch input modes	S-VIDEO (When ③ is VIDEO)	VIDEO (When ③ is VIDEO)
		RGB2 (When ③ is RGB)	RGB1 (When ③ is RGB)
⑥	Switch DVI modes	DVI (When ③ is RGB)	VIDEO (When ③ is VIDEO)
			RGB (When ③ is RGB)

### Note

- The "POWER", "RGB" and "VIDEO" buttons on the remote control and projector will not operate when pins 1 and 9 are shorted. RS-232C commands will also be ignored.
- Do not short pins. 1, 2, 3, 5 or 6 when pin 9 is open. If this is done, the projector will ignore signals from the remote control.





# Indication of lamp monitor

This projector is equipped with 3 indicators to show when a lamp needs replacement or there is an abnormal internal temperature. These lamps flash or light up to indicate a problem.

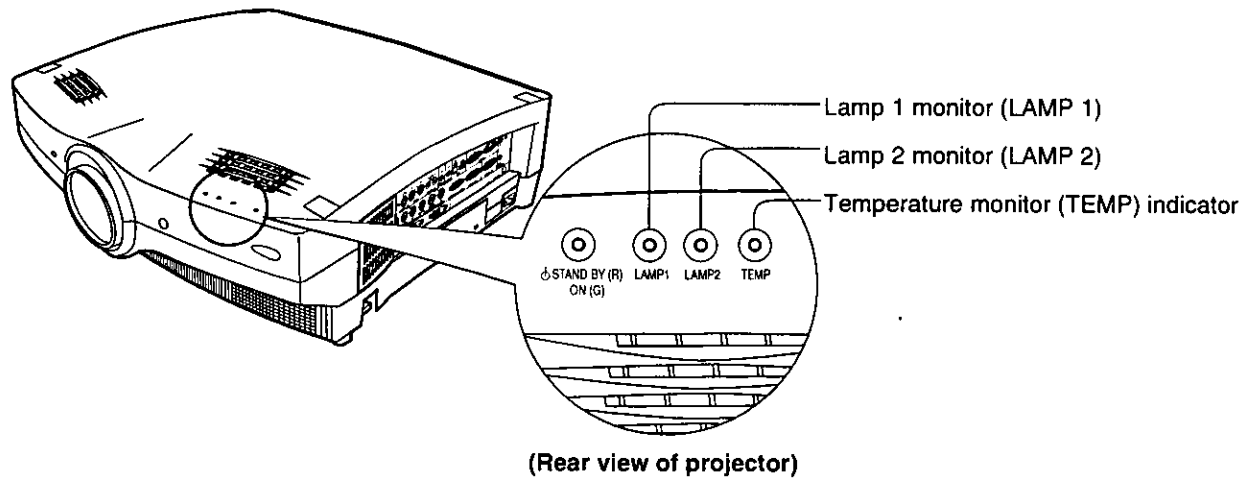
Turn the power off and follow the steps below.



Indicator	Display	Condition	Check	Measures
<b>Temperature monitor</b>  TEMP	Red lamp lit (lamp unit lit)	The internal temperature is too high.	<ul style="list-style-type: none"> <li>• Is something blocking the vent?</li> <li>• Has the projector been operating in a hot location?</li> <li>• Is the air filter clogged?</li> </ul>	<ul style="list-style-type: none"> <li>• Remove the object blocking the vent.</li> <li>• Use the projector only in an environment having a temperature of 0 °C to 40 °C and humidity of 20% to 80% (with no condensation).</li> <li>• Turn the power off by following the steps on page 23 and clean the air filter. (See page 41)</li> </ul>
	Red lamp flashing (lamp unit not lit)	The lamp unit has automatically turned off (standby mode) because the internal temperature was too high.		
	Red lamp lit (Lamp unit not lit)	The lamp unit has automatically turned off (standby mode) because of a high temperature or sudden rise in internal temperature.		
<b>Lamp monitor</b>   LAMP1 LAMP2	Red lamp lit	It is time to replace the lamp unit.	Is replace lamp displayed on the screen when the power is turned on?	Lights when lamp runtime exceeds 1800 hours. Have your dealer replace the lamp unit.
	Red lamp flashing	Detected the Lamp circuit abnormal condition.	Are you turning the power back on immediately after it has been turned off?  There is a malfunction in the lamp circuit	Wait until the light source lamp cools off before turning the power back on.  Turn the power off by following the steps on page 23 and consult your dealer.

## Caution

- To solve any problems that the TEMP and LAMP monitor show, first turn the power off by following the steps on page 23.
- If the main power turns off after the TEMP monitor flashes, the projector has malfunctioned. Please consult your dealer.

# Cleaning and replacing the air filter

If too much dust accumulates on the air filter, the internal temperature of the projector will rise. Eventually the TEMP indicator will flash and the power will turn off.

Clean the air filter approximately every 100 hours of use, although more frequent cleaning may be necessary depending on the environment.

## ■ Cleaning method

### 1. Turn the Main Power off and remove the power plug.

Turn the power off by following the steps on page 23, and remove the power plug.

### 2. Remove the air filter cover.

Remove the air filter cover by pushing down on the tab and pulling forward.

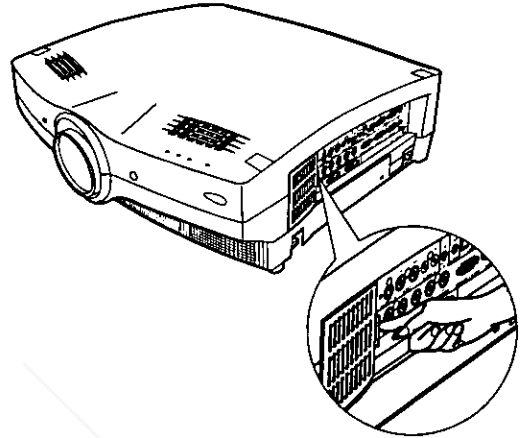

### 3. Clean the air filter.

Remove accumulated dust using a vacuum cleaner.

#### Caution

- Be careful not to suck the air filter into the vacuum cleaner.

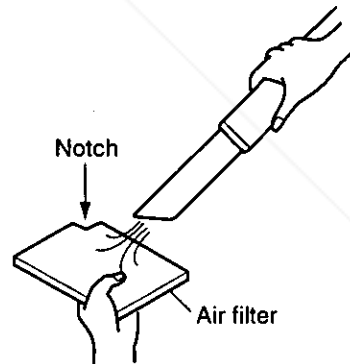

### 4. Attach the air filter and cover.

Place an air filter inside the air filter cover, and replace the cover by reversing the step described in (2).

#### Caution

- Place the air filter aligning the notch toward the upper right direction.
  - Do not operate the projector without the air filter.
- If the projector is operated without the air filter, dust will enter the unit and may cause a malfunction.

#### Note

- If dust cannot be removed with a vacuum cleaner, it is time to replace the filter. Please consult your dealer. Replace the air filter when replacing the lamp unit.

# Replacing the lamp unit

## Caution!

Replacement of the lamp unit should only be carried out by a qualified technician.

## Caution!

Replace the lamp unit only after it has completely cooled off.

### Notes when replacing the lamp unit:

- The internal pressure of the light source is high, therefore if it is struck by hard objects or dropped, it may cause damage. Be careful when handling.
- Handle the old lamp unit with care as it is easily broken.
- A Philips screwdriver is necessary when replacing the lamp unit. Be careful not to slip when using the screwdriver.

### Caution

- The lamp unit is sold separately. Please consult the service/parts center at your dealer.  
Lamp unit model number: ET-LAL6500 (1 lamp) ET-LAL6500W (2 lamps)
- Lamps other than those indicated above must not be used with this projector. Be sure to use the specified lamp.

## ■ Lamp replacement period

The light source lamp of this projector has a life cycle of 2000 hours (Lamp power---hi, Lamp selection---dual setting). However, this duration may be reduced depending on the usage of the projector-the frequency in which the light is turned on and of its intervals affect the life of the lamp. Therefore it is recommended that a spare lamp be made available before 2000 hours have elapsed. If the lamp unit is not replaced after 1800 hours, the power will automatically shut off after 2000 hours and enter standby mode. If the power is turned on after 2000 hours, it will turn off automatically after approximately 10 minutes and enter standby mode.

### • Display after 1800 hours

The lamp monitor indicators (LAMP 1 or LAMP2) will light after the lamp unit runtime has elapsed 1800 hours even during standby mode.

An on-screen message indicating lamp replacement is necessary will be displayed on the screen 30 seconds.

(This on-screen message will disappear after 30 seconds or the projector operation buttons remote control buttons are operated.)

This on-screen message does not disappear, unless a "MENU" buttons or sound adjustment ("VOLUME +/-") buttons will be pushed, if it reaches in 2000 hours.

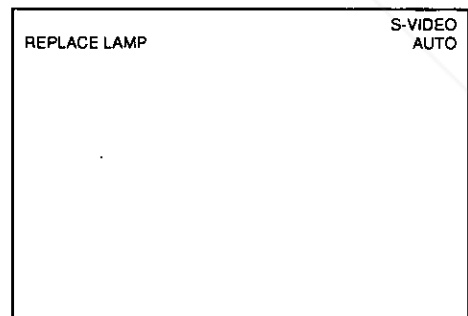

## ■ Lamp unit replacement steps

### Caution

- After 2000 hours of operating the same lamp, it is only possible to operate the unit for approximately 10 minutes. Replace the lamp and steps 8 to 14 must be completed within 10 minutes:

1. Turn the power off by following the steps on page 23, remove the power plug and confirm that the surroundings of the lamp unit have cooled off.

2. Using a Phillips screwdriver, remove the 4 screws on the lamp unit cover located on the rear of the projector.

3. Remove the lamp unit cover by pulling it forward.

### Caution

- Be careful not to break the tab located in the center of the lower side of the lamp unit cover.

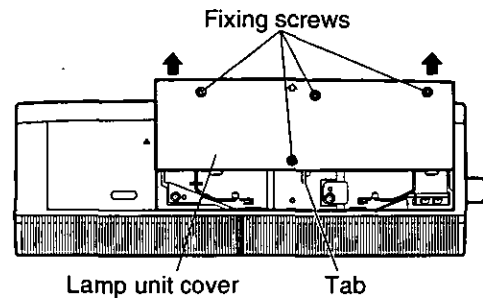

4. Use a Phillips screwdriver to loosen the two lamp unit fixing screws until the screws turn freely. Then hold the handle of the lamp unit and gently pull it out from the projector.

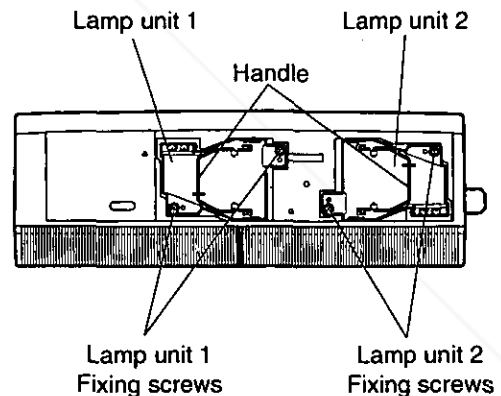

## Caution

The lamp unit will be hot after it has been used.

You might get burned if you touch it while it is still hot.

5. Install the new lamp unit.

6. Use a Phillips screwdriver to securely tighten the 2 lamp unit fixing screws.

7. Install the lamp unit cover, and then use a Phillips screwdriver to securely tighten the lamp unit cover fixing 4 screws.

### Caution

- Firmly install the lamp unit and lamp unit cover. If not installed firmly, a protection circuit will function and the power will not be turned on.

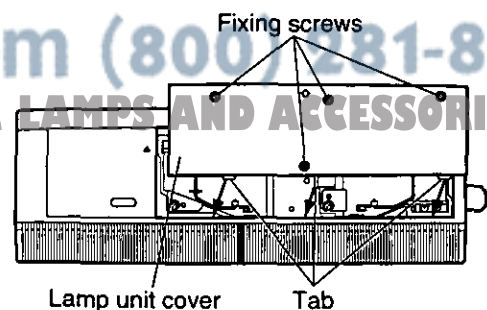

# Replacing the lamp unit

8. Insert the power cord plug into the wall outlet and then press the MAIN POWER switch.

## Caution

- If the power does not turn on even after turning the MAIN POWER switch “O”, turn the MAIN POWER “I”, confirm that the lamp unit and door are installed correctly, and turn on again.

9. Press the “POWER” button so that a picture is projected onto the screen.

10. Press the “MENU” button to display the MAIN MENU screen, and then press the ▲ and ▼ buttons to move the cursor to select “OPTION2”.

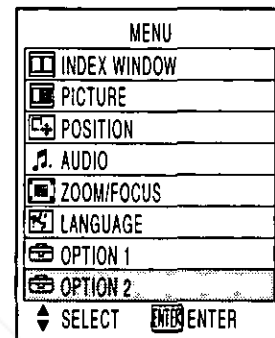

11. Press the “ENTER” button to display the “OPTION2” screen, and then use the ▲ and ▼ buttons to select “LAMP RUNTIME”.

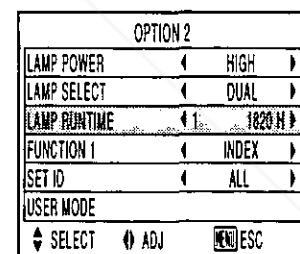

12. Press and hold the “ENTER” button on the projector or the remote control for approximately 3 seconds.

The “LAMP RUNTIME” will change to “L1 RESET [POWER OFF]” or “L2 RESET [POWER OFF]”.

## Note

- If the “MENU” button is pressed, the lamp time resetting screen will be cancelled.

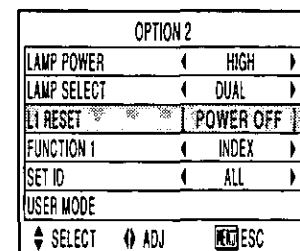

13. Press the ▲ and ▼ buttons to select for replacement lamp setting.

- L1 RESET: Replace the LAMP1
- L2 RESET: Replace the LAMP2
- L1+L2 RESET: Replace the LAMP1 & LAMP2

14. Press the POWER button to turn off the power.

This will reset the cumulative usage time for the lamp unit to zero.

FixYourDLP.com

Sponsored by DM

Discontinued  
THE TRUSTED SOURCE FOR PROJECTOR LAMPS AND ACCESSORIES (800) 281-8860

# Before asking for service

—Before asking for service, check the following points.

Symptoms	Checks
<p><b>Power does not turn on</b></p>	<ul style="list-style-type: none"> <li>• Is the power cord plug correctly plugged in?</li> <li>• Is the MAIN POWER turned on?</li> <li>• Is electricity running to the power outlet?</li> <li>• Is the temperature monitor (TEMP) indicator on the front of the unit flashing or turned on? (See page 40)</li> <li>• Is the lamp monitor (LAMP) indicator on the front of the unit flashing or turned on? (See page 40)</li> <li>• Is the lamp unit door installed correctly?</li> <li>• A wrong ID is set. (See pages 15 and 36)</li> </ul>
<p><b>No image</b></p>	<ul style="list-style-type: none"> <li>• Is the lens cap still on the lens?</li> <li>• Is the image input correctly connected?</li> <li>• Is the input mode set correctly? (See page 23)</li> <li>• Is the black level adjustment set at the minimum level? (See page 30)</li> <li>• Is the equipment connected to the projector operating correctly?</li> <li>• Is the shutter function turned on? (See page 25)</li> </ul>
<p><b>Image is blurred</b></p>	<ul style="list-style-type: none"> <li>• Is the lens focused properly? (See page 23)</li> <li>• Is the projection distance correct? (See page 18)</li> <li>• Is the lens dirty?</li> <li>• Is the projector positioned directly in front of the screen? (See page 18)</li> </ul>
<p><b>Light color/ bad color tone</b></p>	<ul style="list-style-type: none"> <li>• Is the color density and color tone setting correct? (See page 30)</li> <li>• Is the equipment connected to the projector correctly adjusted?</li> </ul>
<p><b>No sound</b></p>	<ul style="list-style-type: none"> <li>• Is the sound input correctly connected?</li> <li>• Is the volume set to the minimum level? (See page 23 and 27)</li> <li>• Is the shutter or mute turned on? (See page 25 and 35)</li> <li>• Is the cable connected to the AUDIO OUT terminal?</li> </ul>
<p><b>Remote control does not operate</b></p>	<ul style="list-style-type: none"> <li>• Are the batteries exhausted?</li> <li>• Are the battery polarities set correctly? (See page 14)</li> <li>• Are there any obstacles between the remote control and the remote control sensor? (See page 14)</li> <li>• Are you trying to operate the remote control beyond its operable range? (See page 14)</li> <li>• Are you controlling from external equipment using the REMOTE terminal? (See page 39)</li> <li>• Is there any external light interfering with remote control operation?</li> <li>• A wrong ID is set. (See pages 15 and 36)</li> </ul>
<p><b>Abnormal image</b></p>	<ul style="list-style-type: none"> <li>• Is the input mode properly set? (See page 23)</li> <li>• Is the correct signal system (TV system) selected? (See page 31)</li> <li>• Are there any malfunctions on the source side, such as bad video tapes?</li> <li>• Are you inputting a signal that is not compatible with this projector? (See page 48)</li> </ul>
<p><b>Does not display images from PCs</b></p>	<ul style="list-style-type: none"> <li>• Is the cable too long?</li> <li>• Is the video output signal setting of the notebook computer correctly set? Setting : <b>[Fn]+[F3]</b> key (Read the operating instructions of the your PC.)</li> </ul>



Discount-Merchant.com (800) 281-8860  
 THE TRUSTED SOURCE FOR PROJECTOR LAMPS AND ACCESSORIES

# Specifications

Model No.	PT-L6500U (XGA)	PT-L6600U (SXGA)	
Supply voltage	100 V - 120 V AC, 50/60 Hz		
Power consumption	600 W (approx. 9 W in Standby mode with fan inactive)		
LCD panel	Panel size	1.3 inch diagonal (aspect ratio: 4:3) with microlens array	
	Display system	3 transmissive LCD panels (3 primary colors)	
	Driving scheme	Active matrix	
	Pixel count	786,432 pixels (1,024 x 768 dots) x 3	1,398,784 pixels (1,366 x 1,024 dots) x 3
Lens	Powered zoom	1 to 1.3	
	powered focus control	F = 1.7 to 2.3, f = 49.1 to 63.8	
Projection lamp	2 UHM lamps with 220 W rating each		
Optical output	3 600 lm (ANSI)		
Scanning frequency	Composite/S-Video	H = 15.74/15.63 kHz, V = 50/60 Hz	
	RGB signal	H = 24 to 97 kHz, V = 50 to 120 Hz, PIAS (Panasonic Intelligent Auto Scanning) format	
		Dot clock frequency: under 132 MHz	Dot clock frequency: under 162 MHz
	DVI-D signal	VGA60, S-VGA60, XGA60, S-XGA60	
	YPaPr signal	[480i] H = 15.75 kHz V = 60 Hz	[625i] H = 15.63 kHz V = 50 Hz
	[480p] H = 31.5 kHz V = 60 Hz	[720p] H = 45 kHz V = 60 Hz	
	[1035i] H = 33.75 kHz V = 60 Hz	[1080i] H = 33.75 kHz V = 60 Hz	
YPaPr signal	480i, 480p, PAL (625i), 720p, 1 035i, 1080i		
Compatible TV standards	6 standards (NTSC, NTSC4.43, PAL, PAL-M, PAL-N, SECAM)		
Screen size	30 to 300 inches diagonal		
Projection distance	1.4 to 13.2 meters		
Optical axis shift span	10:10 to 1:19		
Aspect ratio	4:3 (SXGA 5:4)		
Projection scheme	Menu-selectable from front, rear, ceiling mount, and floor standing		
Speaker	2 oval speakers (4 x 7 cm)		
Audio output power	6 W (3 W + 3 W) (stereo)		
Interface port	DVI-D input/output	1 set DVI-D 24pin	
	RGB1 (x1) input	1 set BNC x 5 [YPaPr input] Y: 1.0 V [p-p] including sync. signal P <sub>Pr</sub> : 0.7 V [p-p] 75 Ω [RGB input] 0.7 V [p-p] 75 Ω G-Sync.: 1.0 V [p-p] 75 Ω HD/SYNC: TTL-compatible, high-impedance w/ auto active Hi/Lo switching VD: TTL-compatible, high-impedance w/ auto active Hi/Lo switching	

Interface port	<b>RGB2 input</b>	High-density D-sub 15-pin connector (female) YPbPr input: Y = 1.0 V [p-p] including sync. signal PbPr = 0.7 V [p-p] 75 Ω RGB input: 0.7 V [p-p] 75 Ω G-Sync.: 1.0 V [p-p] 75 Ω HD/SYNC: TTL-compatible, high-impedance w/ auto active Hi/Lo switching VD: TTL-compatible, high-impedance w/ auto active Hi/Lo switching
	<b>Audio input for RGB 1/2</b>	1 set stereo minijack, 0.5 V [rms]
	<b>VIDEO</b>	BNC x 1 1.0 V [p-p] 75 Ω
	<b>S-video</b>	4-pin mini-Din x 1 Y = 1.0 V [p-p] C = 0.286 V [p-p] 75 Ω
	<b>Audio input for composite/S-video</b>	RCA jack x 2 (L/R), 0.5 V [rms]
	<b>Audio output</b>	1 set stereo minijack, (monitor output, stereo-compatible), 0 V [rms] to 2.0 V [rms] (variable)
	<b>RGB output</b>	High-density D-sub 15-pin connector (female) x 1 YPbPr output: Y = 1.0 V [p-p] including sync. signal PbPr = 0.7 V [p-p] 75 Ω RGB output: 0.7 V [p-p] 75 Ω G-Sync.: 1.0 V [p-p] 75 Ω HD: TTL-compatible, high impedance VD: TTL-compatible, high impedance
	<b>SERIAL</b>	9-pin D-sub connector (female) Use the RS-232C serial port For PC Control
	<b>REMOTE</b>	9-pin D-sub connector (female) For wired mode
	<b>WIRED input</b>	M3 jack 1 set Wired remote control, For daisy-chain control
	<b>USB input</b>	4-pin square connector Type B For wired mouse
	<b>USB output</b>	Type A For daisy-chain control, Max. 5 V/0.5 A
	<b>Power cord</b>	2.5 meters
	<b>Enclosure</b>	Resin mold part
	<b>Outer dimensions</b>	Width: 495mm Height: 179 mm Depth: 495 mm
<b>Weight</b>	13.8 kg (30.4 lbs.)	
<b>Operating conditions</b>	Operating temperature range: 0 °C to 40 °C Operating humidity range: 20 % to 80 % (with no condensation)	
Remote control	<b>Power supply</b>	3 V DC (2 type-AAA dry batteries)
	<b>Control range</b>	Approx. 7 m (in front of light receiver)
	<b>Weight</b>	108 g (3.8 ozs.) (with batteries)
	<b>Outer dimensions</b>	(W) : 33 mm (H) : 40 mm (D) : 168 mm



# Appendix

## <Compatible RGB/YP<sub>B</sub>PR Signals>

The following table specifies the types of RGB/YP<sub>B</sub>PR signals compatible with the projector.

If signals other than this are applied, the projector may produce anything from a distorted display to simply the default (blue or black) background.

Resolution	Compatible Signal		
	H x V Pixels	H. Scanning Frequency (kHz)	V. Scanning Frequency (Hz)
VGA400	640 x 400	24.8	56.4
	640 x 400	31.5	70.1
VGA480	640 x 480	31.5	59.9
	640 x 480	35.0	66.7
	640 x 480	37.9	72.8
	640 x 480	37.5	75.0
	640 x 480	43.3	85.0
	800 x 600	32.1	51.0
SVGA	800 x 600	35.2	56.3
	800 x 600	37.9	60.3
	800 x 600	48.1	72.1
	800 x 600	46.9	75.0
	800 x 600	53.7	85.1
	1 024 x 768	48.4	60.0
XGA	1 024 x 768	56.5	70.1
	1 024 x 768	60.0	75.0
	1 024 x 768	65.5	81.6
	1 024 x 768	68.7	85.0
	1 024 x 768i	35.5	86.8
	1 024 x 768	80.7	100.8
	1 024 x 768	94.0	120.0
MXGA	1 152 x 864	63.9	70.0
	1 152 x 864	67.5	75.0
	1 152 x 864	77.1	85.0
	1 120 x 750	50.1	60.1
	1 120 x 750i	32.6	80.0
SXGA	1 280 x 1 024	52.4	50.0
	1 280 x 1 024	64.0	60.0
	1 280 x 1 024	72.4	66.3
	1 280 x 1 024	78.2	71.7
	1 280 x 1 024	80.0	75.0
	1 280 x 1 024*	91.2	85.0
	1 280 x 1 024i	46.2	86.0
	1 280 x 1 024i	47.6	88.9
UXGA	1 600 x 1 200	75.0	60.0
	1 600 x 1 200	87.5	70.0
	1 600 x 1 200	93.8	75.0
MAC16	832 x 624	49.7	74.6
MAC21	1 152 x 870	68.6	75.0
HDTV	1 920 x 1 035i	33.8	60.0
720p	1 280 x 720	45.0	60.0
NTSC	768 x 480i	15.7	59.9
PAL	768 x 576i	15.6	50.0
480p	720 x 483	31.5	59.9

\* PT-L6600U ONLY

Discount-Merchant.com (800) 281-8860

THE TRUSTED SOURCE FOR PROJECTOR LAMPS AND ACCESSORIES

### Note

- The PT-L6600U has a pixel resolution of 1 366 x 1 024. Pixel data exceeding this resolution is converted into 1 366 x 1 024 pixels.
- The PT-L6500U has a pixel resolution of 1 024 x 768. Pixel data exceeding this resolution is converted into 1 024 x 768 pixels.
- Suffix "i" denotes interlaced scanning.

# Dimensions

unit : mm ( ) : inch

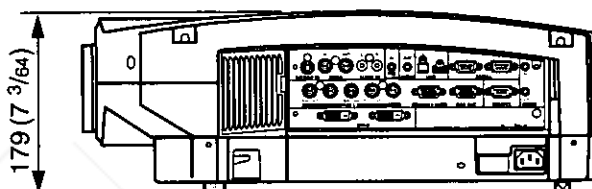
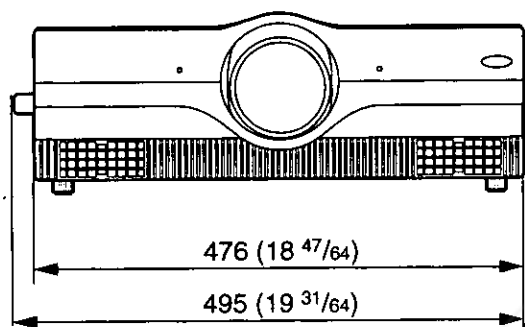
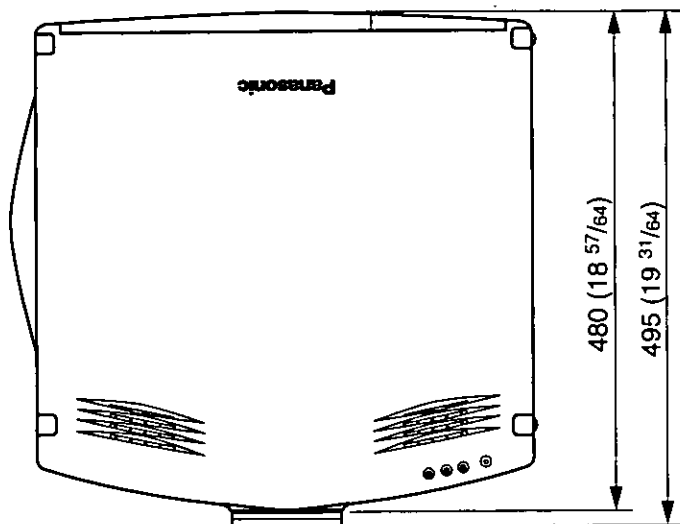

 FixYourDLP.com  
Sponsored by 

**Discount-Merchant.com (800) 281-8860**  
**THE TRUSTED SOURCE FOR PROJECTOR LAMPS AND ACCESSORIES**

# Trademark acknowledgments

---

## Trademark

- PS/2, VGA, and XGA are trademarks of U.S. IBM Corporation.
- Macintosh is a registered trademark of U.S. Apple Computers, Inc.
- PC-98 is a trademark of NEC Corporation.
- S-VGA is a trademark or registered trademark of the Video Electronics Standards Association.
- Windows is a registered trademark of Microsoft Corporation.

The rights of trademarks or registered trademarks not specified are recognised.

## Caution

This product is a Class-A information equipment and complies with the requirements of FCC. Using this product in a home environment may cause interference to other electronic apparatus. In such an event, the user must take the necessary countermeasures.

# NOTES IMPORTANTES

## CONCERNANT LA SÉCURITÉ

**AVERTISSEMENT: POUR RÉDUIRE LES RISQUES DE FEU OU DE CHOC ÉLECTRIQUE, NE PAS EXPOSER CE PRODUIT À L'EAU OU À L'HUMIDITÉ**



Le symbole de la flèche en forme d'éclair, dans un triangle, avertit l'utilisateur de la présence de "tensions dangereuses" à l'intérieur du produit qui peuvent être de force suffisante pour constituer un risque de choc électrique aux personnes.



Le point d'exclamation dans un triangle avertit l'utilisateur de la présence d'instructions importantes concernant l'utilisation et l'entretien (réparation) dans la littérature accompagnant le produit.

**ATTENTION:** Cet appareil est équipé d'une fiche de courant à trois broches avec mise à la terre. Ne pas retirer la broche de mise à la terre de la fiche. Cette fiche ne pourra être utilisée que dans une prise avec mise à la terre. Ceci est une précaution sécuritaire. S'il est impossible d'insérer la fiche dans la prise, s'adresser à un électricien. Ne pas annuler la protection de la fiche à mise à la terre.

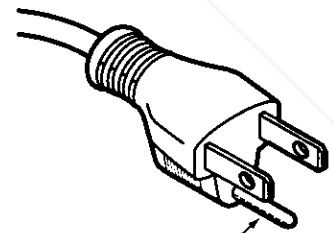

Ne pas retirer

FixYourDLP.com  
Sponsored by DM

**Discount-Merchant.com (800) 281-8860**  
THE TRUSTED SOURCE FOR PROJECTOR LAMPS AND ACCESSORIES

# Précautions concernant la sécurité

---

## AVERTISSEMENT

**En cas de problème (pas d'image ou de son), ou si le projecteur dégage de la fumée ou une odeur étrange, éteindre l'appareil et débrancher immédiatement la fiche d'alimentation de la prise de courant.**

- Ne pas continuer d'utiliser le projecteur dans ces cas, autrement cela peut entraîner un incendie ou des chocs électriques.
- Après s'être assuré que de la fumée ne se dégage plus, s'adresser à un centre technique agréé et demander que les réparations nécessaires soient faites.
- Le fait de réparer le projecteur soi-même est très dangereux, et ne doit jamais être fait.

**Ne pas installer ce projecteur dans un endroit qui n'est pas assez résistant pour supporter le poids du projecteur.**

- Si l'emplacement d'installation n'est pas assez résistant, le projecteur risque de tomber et causer de graves blessures et (ou) des dommages.

**Demander à un technicien qualifié d'installer le projecteur par exemple s'il est installé au plafond.**

- Si l'installation n'est pas faite correctement, cela peut entraîner des blessures ou des chocs électriques.

**Si de l'eau ou des objets étrangers entrent dans le projecteur, si le projecteur tombe, ou si le boîtier est endommagé, éteindre l'appareil et débrancher immédiatement la fiche d'alimentation de la prise de courant.**

- Si l'on continue d'utiliser le projecteur dans ces conditions, cela peut entraîner un incendie ou des chocs électriques.
- S'adresser à un centre technique agréé pour que les réparations nécessaires puissent être faites.

**Ne pas couvrir le filtre et la sortie d'air.**

- Cela risque de faire surchauffer le projecteur, et causer un incendie ou endommager le projecteur.

**Ne pas surcharger la prise de courant.**

- Si l'alimentation est surchargée (par exemple, par l'utilisation de trop d'adaptateurs), cela risque de faire surchauffer le projecteur et peut entraîner un incendie.

**Ne pas retirer le couvercle ou le modifier.**

- Des hautes tensions qui peuvent causer de graves blessures sont présentes à l'intérieur du projecteur.
- Pour toute inspection, réglage ou réparation, s'adresser à un centre technique agréé.

**Nettoyer la fiche du cordon d'alimentation régulièrement afin d'éviter toute accumulation de poussière.**

- Si de la poussière s'accumule sur la fiche du cordon d'alimentation, l'humidité peut endommager l'isolant et entraîner un incendie. Débrancher le cordon d'alimentation de la prise de courant et l'essuyer avec un chiffon sec.
- Si le projecteur ne sera pas utilisé pendant une période prolongée, débrancher le cordon d'alimentation de la prise de courant.

**Prendre attention de ne pas endommager le cordon d'alimentation.**

- Ne pas endommager le cordon d'alimentation, ne pas le modifier, ne pas placer d'objets lourds, ne pas le chauffer, ne pas le placer près d'objets chauffants, ne pas le tordre, ne pas le plier ou le tirer excessivement et ne pas le rouler en boule.
- Si le cordon d'alimentation est endommagé, cela peut entraîner un incendie et des chocs électriques.
- Si le cordon d'alimentation est endommagé, le faire réparer par un centre technique agréé.

**Ne pas manipuler le cordon d'alimentation avec les mains mouillées.**

- Cela peut entraîner des chocs électriques.

---

### **Brancher la fiche du cordon d'alimentation fermement dans la prise de courant.**

- Si la fiche n'est pas complètement insérée, cela peut entraîner des chocs électriques ou la faire surchauffer.
- Si la fiche est endommagée ou la plaque de la prise est desserrée, elles ne devraient pas être utilisées.

### **Ne pas placer le projecteur sur des surfaces instables.**

- Si le projecteur est placé sur une surface qui est inclinée ou instable, il risque de tomber ou de se renverser et cela peut causer des blessures ou des dommages.

### **Ne pas placer le projecteur dans l'eau ou ne pas le laisser se mouiller.**

- Sinon cela peut causer un incendie ou des chocs électriques.

### **Ne pas placer des récipients de liquide sur le projecteur.**

- Si de l'eau se renverse sur le projecteur, s'adresser à un centre technique agréé.
- Si n'importe quel liquide s'infiltre à l'intérieur du projecteur, entrer en contact avec un centre commercial autorisé.

### **Ne pas mettre d'objets étrangers dans le projecteur.**

- Ne pas insérer d'objets métalliques ou inflammables dans les orifices de ventilation ou les faire tomber sur le projecteur, car cela peut causer un incendie ou des chocs électriques.

### **Après avoir retiré la pile de la télécommande, la garder hors de la portée des enfants.**

- Si avalée, la pile peut causer la mort par suffocation.
- Si la pile est avalée, s'adresser à un médecin immédiatement.

### **Ne pas laisser les bornes + et - de la pile entrer en contact avec des objets métalliques tels que des colliers ou des épingles à cheveux.**

- Cela peut faire que la pile fuit, surchauffe, éclate ou prenne feu.
- Garder la pile dans un sachet en plastique et la maintenir éloignée des objets métalliques.

### **Isoler la pile à l'aide de ruban ou autre avant de la mettre au rebut.**

- Si la pile entre en contact avec des objets métalliques ou d'autres piles, elle peut prendre feu ou éclater.

### **Les enfants ne doivent pas utiliser la télécommande et ne pas regarder le rayon laser émis par la télécommande**

- Bien que l'émission laser de la télécommande ne soit pas nuisible pour la santé humaine, ne regardez pas directement le rayon laser ni ne le dirigez directement sur quelqu'un.
- Les radiations laser peuvent causer des blessures oculaires.

## **Attention**

### **Ne pas installer le projecteur dans des endroits humides ou poussiéreux ou dans des endroits où le projecteur peut entrer en contact avec de la fumée ou la vapeur.**

- L'utilisation du projecteur dans de telles conditions peut causer un incendie ou des chocs électriques.

### **Pour débrancher le cordon d'alimentation, tenir la fiche et non pas le cordon.**

- Si le cordon d'alimentation est tiré, le cordon sera endommagé et cela peut causer un incendie, des courts-circuits ou des chocs électriques sérieux.

### **Débrancher toujours tous les câbles avant de déplacer le projecteur.**

- Le fait de déplacer le projecteur avec des câbles branchés peut endommager les câbles, ce qui pourrait causer un incendie ou des chocs électriques.

### **Ne pas placer d'objets lourds sur le projecteur.**

- Cela peut déséquilibrer le projecteur et le faire tomber, ce qui peut entraîner des dommages ou des blessures.

# Précautions concernant la sécurité

---

**Ne pas court-circuiter, chauffer ou démonter la pile et ne pas la placer dans l'eau ou le feu.**

- Cela peut faire que la pile fuit, surchauffe, éclate ou prenne feu et causer des brûlures ou autres blessures.

**Lors de l'insertion de la pile, s'assurer que les polarités (+ et -) sont correctes.**

- Si la pile est insérée incorrectement, elle peut éclater ou fuir et cela peut causer un incendie, des blessures ou la contamination du compartiment des piles.

**N'utiliser que la pile indiquée.**

- Si une pile incorrecte est utilisée, elle peut éclater ou fuir et cela peut causer un incendie, des blessures ou la contamination du compartiment des piles.

**Ne pas regarder directement dans la lentille pendant que le projecteur fonctionne.**

- Une lumière intense est émise par la lentille du projecteur. Si l'on regarde directement dans cette lumière, elle risque de causer des blessures et de graves lésions aux yeux.

**Ne pas placer les mains ou autres objets près de la sortie d'air.**

- De l'air chaud sort par l'ouverture de sortie d'air. Ne pas placer les mains ou le visage, ou d'autres objets qui ne peuvent résister à la chaleur près de cette sortie d'air, sinon cela peut causer des blessures ou des dommages.

**Le remplacement de l'unité de lampe ne devrait être effectué que par un technicien qualifié.**

- L'unité de lampe a une pression interne élevée. Elle peut facilement s'endommager si cognée contre des objets durs ou si elle tombe, et cela peut causer des blessures ou des mauvais fonctionnements.

**Débrancher la fiche du cordon d'alimentation de la prise de courant comme mesure de sécurité avant d'effectuer tout nettoyage.**

- Sinon cela peut causer des chocs électriques.

**Demander à un centre technique agréé de nettoyer l'intérieur du projecteur au moins une fois par an.**

- S'il n'est pas nettoyé et que la poussière s'accumule à l'intérieur du projecteur, cela peut causer un incendie ou des problèmes de fonctionnement.
- Il est recommandé de nettoyer l'intérieur du projecteur avant que la saison humide n'arrive. Demander au centre technique agréé le plus proche de nettoyer le projecteur lorsque cela est requis. Se renseigner auprès du centre technique agréé pour le coût du nettoyage.

**Nous faisons tous les efforts possibles afin de préserver l'environnement. Prière d'apporter l'appareil, s'il n'est pas réparable, à votre revendeur ou à un centre de recyclage.**



**Discount-Merchant.com (800) 281-8860**  
**THE TRUSTED SOURCE FOR PROJECTOR LAMPS AND ACCESSORIES**

# Précautions concernant la manipulation

## Avertissements concernant la manipulation

**S'assurer d'attacher le capuchon d'objectif avant de transporter le projecteur.**

La lentille de projection est extrêmement sensible à la vibration et aux chocs.

Utiliser la sacoche de transport pour transporter le projecteur.

## Avertissements concernant l'installation

Toujours observer les points suivants lors de l'installation du projecteur.

**Éviter de l'installer dans les endroits sujets à des vibrations ou à des chocs.**

Si le projecteur est installé dans les endroits sujets à de fortes vibrations, comme près d'un moteur, ou s'il est installé à l'intérieur d'un véhicule ou à bord d'un bateau, le projecteur peut être soumis à une vibration ou à des chocs qui peuvent endommager les pièces internes et causer des mauvais fonctionnements ou des accidents. Dès lors, installer le projecteur dans un endroit qui n'est pas soumis à des vibrations ou des chocs.

**Ne pas installer le projecteur près de lignes d'alimentation électrique à haute tension ou de moteurs.**

Le projecteur peut être sujet à une interférence électromagnétique s'il est installé près de lignes d'alimentation électrique à haute tension ou de moteurs.

**Si le projecteur est installé au plafond, demander à un technicien qualifié de faire tous les travaux d'installation.**

Si le projecteur doit être suspendu au plafond, il faut acheter le kit d'installation séparé (numéro de modèle: ET-PKL6500/S). De plus, tous les travaux d'installation ne devraient être faits que par un technicien qualifié.

## Notes sur l'utilisation

**Afin d'obtenir la meilleure qualité d'image**

Si la lumière extérieure ou la lumière des lampes intérieures brille sur l'écran, les images projetées n'auront pas un bon contraste. Tirer les rideaux ou les stores de toutes les fenêtres et éteindre toutes les lumières fluorescentes près de l'écran pour empêcher la réflexion.

**Ne pas toucher aux surfaces de la lentille avec les mains nues.**

Si la surface de la lentille est salie par des empreintes digitales ou autre, ceci sera agrandi et projeté sur l'écran. D'ailleurs, lorsque le projecteur n'est pas utilisé, rétracter la lentille, puis la couvrir à l'aide du capuchon d'objectif accessoire.

**À propos de l'écran**

Si l'écran utilisé est sale, endommagé ou décoloré, des projections de bonne qualité ne peuvent pas être obtenues. N'appliquer aucune substance volatile à l'écran et ne pas le laisser se salir ou s'endommager.

**Avant de faire le nettoyage et l'entretien, s'assurer de**

**débrancher la fiche du cordon d'alimentation de la prise de courant.**

**Essuyer le boîtier avec un tissu doux et sec.**

Si le boîtier est très sale, imbiber le chiffon dans de l'eau avec un peu de détergent neutre, bien essorer le chiffon, puis essuyer le boîtier. Après le nettoyage, sécher le boîtier à l'aide d'un chiffon sec.

**Si un chiffon traité chimiquement est utilisé, lire les directives fournies avec le chiffon avant de l'utiliser.**

Ne pas essuyer la lentille avec un chiffon poussiéreux ou pelucheux.

Si de la poussière ou de la peluche se dépose sur la lentille, elle sera agrandie et projetée sur l'écran. Utiliser une poire à air pour nettoyer toute poussière et peluche de la surface de la lentille, ou utiliser un chiffon doux pour retirer toute poussière ou peluche.



# Remplacement du bloc de lampe

## Attention

**Le bloc de lampe ne devrait être remplacé que par un technicien qualifié.**

**Le couvercle du bloc de lampe sera chaud après l'utilisation.**

- **On risque de se brûler si le couvercle du bloc de lampe est touché pendant qu'il est chaud.**

## Notes sur le remplacement du bloc de lampe

- Faire très attention en manipulant le bloc de lampe retiré, car il contient du gaz sous haute pression et peut facilement s'endommager s'il est cogné contre des objets durs ou s'il tombe.
- Le vieux bloc de lampe peut se briser si manipulé rudement après le retrait. Demander à une agence de mise au rebut agréée de s'occuper de mettre au rebut le bloc de lampe retiré.
- Un tournevis cruciforme Phillips sera nécessaire lors du retrait du bloc de lampe. S'assurer que les mains ne glissent pas lors de l'utilisation du tournevis.

### REMARQUE:

- Le projecteur n'est pas fourni avec un bloc de lampe de rechange. Demander les détails au revendeur. Numéro de produit du bloc de lampe: **ET-LAL6500** (1 lampe), **ET-LAL6500W** (2 lampes)

### ATTENTION :

- Ne pas utiliser un bloc de lampe avec un numéro de pièce autre que celui indiqué ci-dessus.

## Période de remplacement du bloc de lampe

La lampe utilisée comme source lumineuse pour ce projecteur doit être remplacée. La durée de fonctionnement normale du bloc de lampe est d'environ 2000 heures, toutefois le bloc de lampe peut cesser de projeter avant que les 2000 heures de fonctionnement soient atteintes, suivant les caractéristiques de la lampe et les conditions dans lesquelles la lampe est utilisée. (Si la lampe est allumée et éteinte très fréquemment, ou si la période d'attente entre l'arrêt et la mise en marche est trop courte, cela peut raccourcir la durée de fonctionnement du bloc de lampe.) Il est recommandé de toujours avoir un bloc de lampe de rechange prêt à l'emploi si nécessaire. Aussi, la durée de vie utile de la lampe peut être prolongée en réglant PUIS LAMPE dans le menu OPTION à "FAIBLE".

Si la lampe n'est pas remplacée après que la durée d'utilisation totale ait dépassé les 1800 heures (lorsque PUIS LAMPE est réglé à "STD"), l'alimentation s'éteindra automatiquement et le projecteur passera au mode d'attente lorsque la durée d'utilisation totale atteint les 2000 heures. Si l'alimentation est mise de nouveau en circuit après que les 2000 heures aient été dépassées, le projecteur passera de nouveau automatiquement au mode d'attente après 10 minutes approximativement.

### Affichage à l'écran lorsque l'utilisation totale dépasse 1800 heures

Si l'on continue d'utiliser le bloc de lampe après 1800 heures d'utilisation totale (lorsque PUIS LAMPE est réglé

à "STD") l'indicateur LAMP (lampe) s'allumera, même si le projecteur est en mode d'attente. L'affichage à l'écran indiqué à droite apparaîtra pour rappeler de remplacer le bloc de lampe 10 minutes avant que l'alimentation s'éteigne automatiquement. Cet affichage continuera d'apparaître jusqu'à ce qu'un bouton comme la touche de "MENU" ou les touches de volume ("VOLUME +/-") soit pressé.

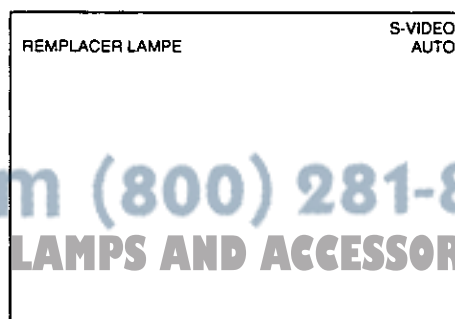

# Précautions concernant la sécurité

## ATTENTION

Le remplacement de la lampe doit être réalisé exclusivement par un technicien habilité. De plus, le cache de la lampe est chaud après utilisation du projecteur.

- Vous risquez de vous brûler si vous touchez le cache de la lampe quand il est chaud.

## REMARQUES SUR LE REMPLACEMENT DE LA LAMPE

- Une fois que vous avez retiré la lampe, manipulez-la avec précaution car elle contient du gaz sous haute pression et elle risque de s'endommager facilement si vous la heurtez contre des objets durs ou si vous la lâchez.
- L'ancienne lampe risque de se briser si vous la manipulez trop rudement après l'avoir retirée. Pour la jeter, conformez-vous aux réglementations en vigueur dans votre région en ce qui concerne de tri des déchets.
- Vous avez besoin d'un tournevis Phillips pour retirer la lampe. Veillez à ce que vos mains ne soient pas glissantes.

## Procédure de remplacement de la lampe

### Remarque

- Lorsque le témoin LAMP est allumé sur le projecteur LCD, le projecteur ne peut être utilisé que pendant 10 minutes après la mise sous tension.
- Si le projecteur LCD fonctionne, éteignez-le selon la procédure suivante et attendez que la lampe refroidisse avant de procéder au remplacement.

1. Assurez-vous que le témoin indicateur de la lampe est allumé (LAMP 1 ou LAMP 2).

Il faut remplacer la lampe si le témoin est rouge.

2. Pressez la touche "POWER" sur le projecteur LCD ou sur la télécommande.

(Le témoin d'alimentation s'allume en orange.)

3. Attendez que le ventilateur de refroidissement s'arrête et que le témoin d'alimentation passe au rouge (environ 60 secondes).

4. Mettez en position d'arrêt l'interrupteur principal et débranchez le cordon d'alimentation de la prise murale.

## ■ Remplacement de la lampe

### Attention

- Les opérations des étapes 8 à 14 doivent donc être réalisées en moins de 10 minutes. Si la durée d'utilisation de la lampe a dépassé 2000 heures, le projecteur se mettra automatiquement hors tension après 10 minutes environ.

FixYourDLP.com

1. Assurez-vous que tout a refroidi autour de la lampe.

2. En utilisant un tournevis Phillips, retirez les 4 vis de la porte d'accès à la lampe située à l'arrière du projecteur.

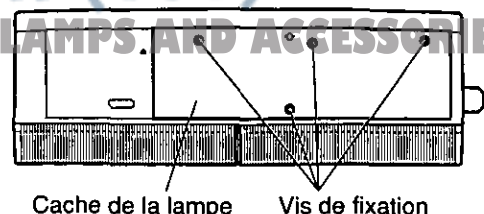

### 3. Retirez la porte en la tirant vers l'avant.

#### Attention

- Faites attention de ne pas casser le cliquet situé au centre de la partie inférieure de la porte d'accès la lampe.

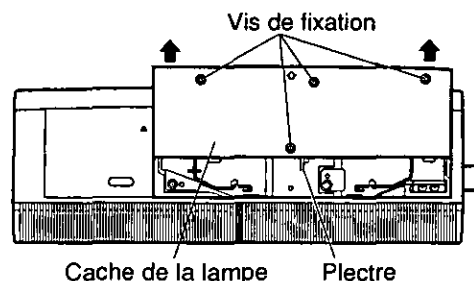

### 4. À l'aide d'un tournevis Phillips, desserrez les deux vis de fixation de la lampe jusqu'à ce qu'elles puissent tourner facilement. Ensuite, saisissez la poignée de la lampe et tirez doucement pour la sortir du projecteur.

## ATTENTION

**La lampe est chaude si elle vient d'être utilisée.**

Vous risquez de vous brûler si vous la touchez alors qu'elle est encore chaude.

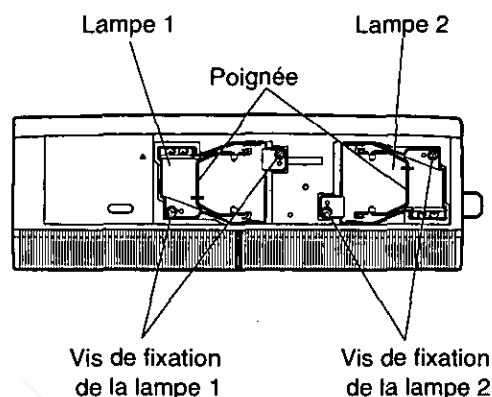

### 5. Installez la nouvelle lampe.

### 6. Utilisez un tournevis Phillips pour serrer correctement les vis de fixation de la lampe (2 pos.).

### 7. Remettez en place le cache de la lampe, puis, à l'aide d'un tournevis Phillips, serrez fermement les vis de fixation du cache de la lampe.

#### Attention

- La lampe et le cache doivent être correctement fixés. Si ce n'est pas le cas, un circuit de protection entre en action et la mise sous tension sera impossible.

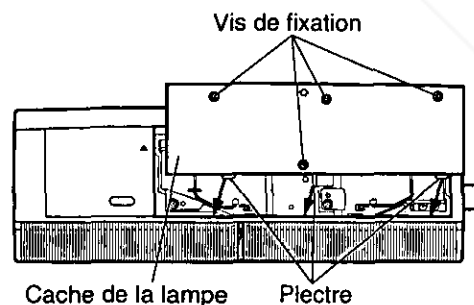

### 8. Branchez la fiche du cordon d'alimentation dans la prise murale et actionnez l'interrupteur MAIN POWER.

#### Attention

- Si la mise sous tension ne s'effectue pas même une fois que vous avez positionné l'interrupteur principal sur "O", remettez ce dernier sur "I", vérifiez que la lampe et son cache sont correctement installés et rallumez.

### 9. Appuyez sur la touche "POWER" afin de projeter une image sur l'écran.

10. Appuyez sur la touche "MENU" pour afficher l'écran du menu principal, puis utilisez les touches ▲ et ▼ pour amener le curseur sur "OPTION 2" et sélectionner cette option.

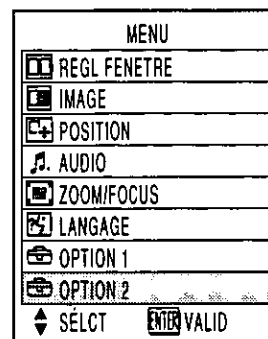

11. Appuyez sur la touche Entrée pour passer dans l'écran "OPTION 2", puis utilisez les touches ▲ et ▼ pour sélectionner "DURÉE LAMPE".

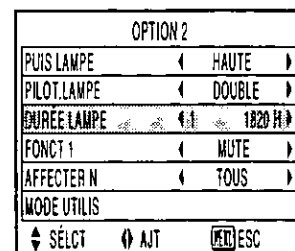

12. Maintenez presse la touche "ENTER" sur le projecteur ou sur la ticommande pendant environ 3 secondes.

L'option "DURÉE LAMPE" devient "RAZ L1 [POWER OFF]" ou "RAZ L2 [POWER OFF]".

#### Remarque

- Si la touche MENU est enfoncée, l'écran de réinitialisation de la durée de la lampe s'annule.

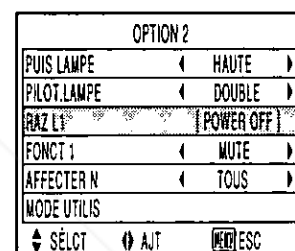

13. Appuyez sur les touches ▲ et ▼ pour sélectionner le paramètre de remplacement de la lampe.

RAZ L1 : remplacement de la lampe 1.

RAZ L2 : remplacement de la lampe 2.

RAZ L1 + L2 : remplacement de la lampe 1 et de la lampe 2.

14. Appuyez sur la touche "POWER" pour couper l'alimentation. La durée d'utilisation cumulée de la lampe revient à zéro.

Accessoire • 1 filtre à air



Discount-Merchant.com (800) 281-8860  
THE TRUSTED SOURCE FOR PROJECTOR LAMPS AND ACCESSORIES

---

# Panasonic®

Professional/Industrial Video

---

## **Panasonic Broadcast & Television Systems Company**

Division of Matsushita Electric Corporation of America

One Panasonic Way 4E-7 Secaucus, NJ 07094 (201) 392-4443  
10 Canuenga Blvd West Los Angeles, CA 90068 (323) 436-3500

### **Technical Support:**

(800) 524-1448

(800) 526-6610

FAX: (201) 392-6514

E-Mail: [pbtssupport@panasonic.com](mailto:pbtssupport@panasonic.com)

---

### **Panasonic Canada Inc.**

5770 Ambler Drive, Mississauga, Ontario L4W 2T3 (905) 624-5010

Printed in Japan

M0201-3041



# Disclaimer

This user manual is provided as a free service by FixYourDLP.com. FixYourDLP is in no way responsible for the content of this manual, nor do we guarantee its accuracy. FixYourDLP does not make any claim of copyright and all copyrights remain the property of their respective owners.

About FixYourDLP.com

FixYourDLP.com (<http://www.fixyourdlp.com>) is the World's #1 resource for media product news, reviews, do-it-yourself guides, and manuals.

Informational Blog: <http://www.fixyourdlp.com>

Video Guides: <http://www.fixyourdlp.com/guides>

User Forums: <http://www.fixyourdlp.com/forum>

FixYourDLP's Fight Against Counterfeit Lamps:

<http://www.fixyourdlp.com/counterfeits>

## Sponsors:

RecycleYourLamp.org – Free lamp recycling services for used lamps:

<http://www.recycleyourlamp.org>

Lamp Research - The trusted 3rd party lamp research company:

<http://www.lampresearch.com>

Discount-Merchant.com – The worlds largest lamp distributor:

<http://www.discount-merchant.com>



**FixYourDLP.com**

Sponsored by 