



Disclaimer

This user manual is provided as a free service by FixYourDLP.com. FixYourDLP is in no way responsible for the content of this manual, nor do we guarantee its accuracy. FixYourDLP does not make any claim of copyright and all copyrights remain the property of their respective owners.

About FixYourDLP.com

FixYourDLP.com (<http://www.fixyourdpl.com>) is the World's #1 resource for media product news, reviews, do-it-yourself guides, and manuals.

Informational Blog: <http://www.fixyourdpl.com>

Video Guides: <http://www.fixyourdpl.com/guides>

User Forums: <http://www.fixyourdpl.com/forum>

FixYourDLP's Fight Against Counterfeit Lamps:

<http://www.fixyourdpl.com/counterfeits>

Sponsors:

RecycleYourLamp.org – Free lamp recycling services for used lamps:

<http://www.recycleyourlamp.org>

Lamp Research - The trusted 3rd party lamp research company:

<http://www.lampresearch.com>

Discount-Merchant.com – The worlds largest lamp distributor:

<http://www.discount-merchant.com>



FixYourDLP.com

Sponsored by 



MP8746/MP8747 Personal Projector

Operator's Guide

MP8746/MP8747 Projecteur personnel Guide de l'opérateur

MP8746/MP8747 Personal Projektor - Benutzerhandbuch

MP8746/MP8747 Guía del usuario del proyector personal

MP8746/MP8747 Guida dell'operatore per il Proiettore personale

MP8746/MP8747 Bruksanvisning för Personlig projektor

MP8746/MP8747 Personal Projector – gebruiksaanwijzing

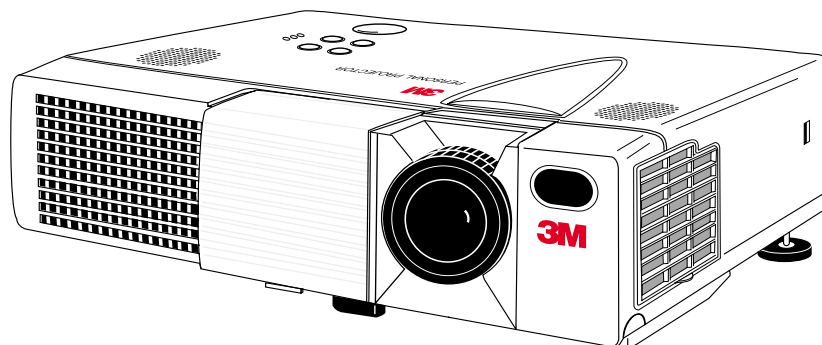

Discount-Merchant.com (800) 281-8860

THE TRUSTED SOURCE FOR PROJECTOR LAMPS AND ACCESSORIES

(This page intentionally left blank for printed version.)



Discount-Merchant.com (800) 281-8860
THE TRUSTED SOURCE FOR PROJECTOR LAMPS AND ACCESSORIES

Table of Contents

On the CD-ROM, please click on any section to jump to that section.

Introduction

Safeguards	4
Thank You for Choosing 3M	6
Warranty	6

Section 1: Unpack

Contents of Shipping Box	7
Optional Accessories	7
Keep Your Packing Materials	7
What's Next?	7

Section 2: Product Description

Machine Characteristics	8
Part Identification List	9
System Setup—Connecting to Various Equipment	10
Remote Control Transmitter Identification	12
Changing Remote Control Battery	13
Mouse Emulation	14
Attaching Handle	15

Section 3: Basic Operations

Projector Startup and Shutdown	16
--------------------------------------	----

Section 4: Adjustments and Functions

How to Use Height Adjustment Foot	17
Plug & Play and Other Functions	18
Menu Navigation	19
Factory Default Setting	19
SETUP Submenu	20
INPUT Submenu	21
IMAGE Submenu	22
OPT Submenu	23

Section 5: Maintenance

Cleaning the Air Filter	24
-------------------------------	----

Section 6: Lamp

Lamp	25
Display Lamp Operation Hours	25
Reset Lamp Hours	25
Replacing the Lamp	26

Section 7: Troubleshooting

Symptoms/Solutions Table	27
Messages/Solutions Table	28
Indicator Lights Table	29
Service Information	30

Section 8: Accessories	30
------------------------------	----

The Technical Appendix is in English only.
Please click here (on the CD-ROM) to read it.

Introduction

Intended Use

Before operating the machine, please read this entire manual thoroughly. The 3M™ Personal Projector MP8746/MP8747 was designed, built, and tested for use indoors, using 3M lamps, 3M ceiling mount hardware, and nominal local voltages. The use of other replacement lamps, outdoor operation, operation in environments containing heavy cigarette smoke or different voltages has not been tested and could damage the projector or peripheral equipment and/or create a potentially unsafe operating condition.

Important Safeguards

1. Read and understand all instructions before using. Pay particular attention to areas where these symbols are shown:

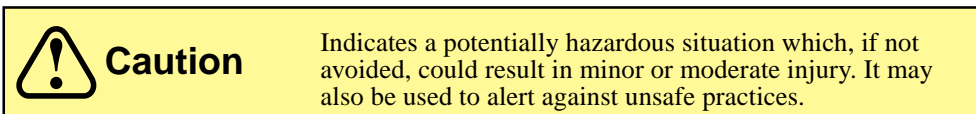

✓ *Note* - Used to emphasize important conditions or details.

2. Close supervision is necessary when any appliance is used by or near children. Do not leave appliance unattended while in use.
3. Never look directly into the projector lens when the lamp is on. The lamp produces a strong light that could damage your eyesight.
- ⚠ 4. Care must be taken, as burns can occur from touching hot parts.
- ⚠ 5. Do not operate appliance with a damaged cord or if the appliance has been dropped or damaged, until it has been examined by a qualified service technician.
- ⚠ 6. Position the cord so that it will not be tripped over, pulled or placed in contact with hot surfaces.
 7. If an extension cord is necessary, a cord with a current rating at least equal to that of the appliance should be used. Cords rated for less amperage than the appliance may overheat.
 8. Always unplug appliance from electrical outlet before cleaning and servicing and when not in use. Grasp plug and pull to disconnect.
 9. To reduce the risk of electric shock, do not immerse this appliance in water or other liquids.
 10. To reduce the risk of electric shock, do not disassemble this appliance. Take it to a qualified technician when service or repair work is required. Incorrect reassembly can cause electric shock when the appliance is subsequently used.
 11. Connect this appliance to a grounded outlet.
 12. Do not expose this projector to direct sunlight or use it outside.
- ⚠ 13. Keep all ventilation openings free of any obstructions.
 14. Always open the lens shutter or remove the lens cap when the projector lamp is on.
 15. Do not look directly into light beam of laser pointer. The pointer produces a strong light which could damage your eyesight.
 16. The projection lamp contains mercury. Always dispose of it in a proper manner according to local regulations.
 17. To prevent lamp from bursting, do not continue using the same lamp after changing the mounting position of the projector (desktop to ceiling mount or ceiling mount to desktop mount).
18. Always operate machine on a flat, sturdy surface.

Introduction

Location of Product Safety Labels

The following safety labels are used on or within the MP8746/MP8747 projector to alert you to items or areas requiring your attention.

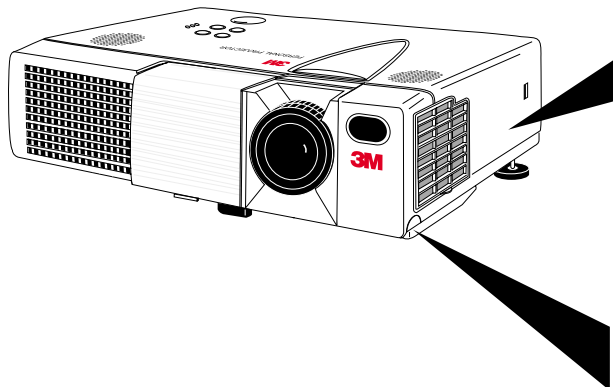

CAUTION/VORSICHT/MESURE DE PRÉCAUTION/ATTENZIONE/PRECAUCIÓN
 Turning the knob too much makes it come off. / Der Verstellknopf löst sich wenn er überdreht wird. / Si vous manipulez excessivement la poignée, elle se détachera. / Se si gira troppo la manipola si stacca. / Grandola demasiado la manivela se desprende.
 H ← → L

HIGH TEMPERATURE / HAUTE TEMPERATURE / HOCHTEMPERATUR / ALTA TEMPERATURA / ALTA TEMPERATURA **3M**

- When replacing lamp, turn off and unplug unit, wait 45 minutes to let lamp cool. High-pressure lamp when hot, may explode if improperly handled.
- Pour changer la lampe, éteindre et débrancher la machine. Attendre 45 minutes de manière à laisser refroidir la lampe. La lampe haute pression risque d'exploser si elle est manipulée sans précaution lorsqu'elle est encore chaude.
- Vor Austausch der Lampe, das Gerät abschalten und den Stecker herausziehen; 45 Minuten warten, um die Lampe abkühlen zu lassen. Falls die heiße Hochdrucklampe falsch gehandhabt wird, kann sie explodieren.
- Prima di sostituire la lampadina, spegnere il proiettore, scollegare la presa di alimentazione ed attendere 45 minuti circa che la lampadina si raffreddi. Se calda, essa è sottoposta ad alta pressione interna e può esplodere.
- Cuando tenga que reemplazar la lámpara, desconecte la alimentación y desenchufe la unidad, y espere 45 minutos para dejar que se enfríe la lámpara. La lámpara, que está a alta presión cuando está caliente, puede explotar si se manipula indebidamente.

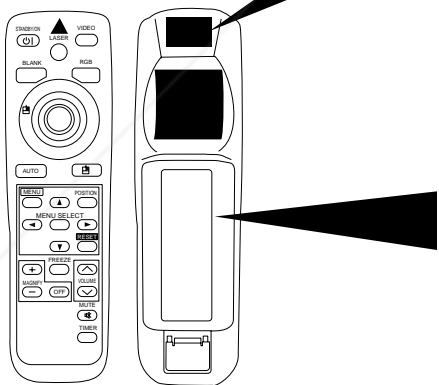

AVOID EXPOSURE- LASER RADIATION IS EMITTED FROM THIS APERTURE

CAUTION

LASER RADIATION- DO NOT STARE INTO BEAM

WAVE LENGTH: 650 nm
 MAX. OUTPUT: 1 mW
 CLASS 2 LASER PRODUCT

RADIAZIONI LASER NON GUARDARE NEL RAGGIO LUCE APPARECCHIO LASER DI CLASSE 2	
RAYONNEMENT LASER NE PAS REGARDER DANS LE FAISCEAU APPAREIL A LASER CLASSE 2	MANUFACTURED May-00
LASER STRAHLUNG NICHT INDEN STRAHL BLICKEN LASER KLASSE 2	PLACE OF MANUFACTURER A MADE IN JAPAN

IEC8025-1-1993+A1: 1997

Caution In some countries, the line voltage is NOT stable. This projector is designed to operate safely within a bandwidth of 90 to 132 volts / 198 to 264 volts (50 to 60 Hz) ± 10 volts, but could fail if power drops or surges of ±10 volts occur. In these high-risk areas, it is recommended to install a power stabilizer unit.

Save These Instructions THE TRUSTED SOURCE FOR PROJECTOR LAMPS AND ACCESSORIES

The information contained in this manual will help you operate and maintain your 3M™ MP8746/MP8747 Personal Projector.

Introduction

Thank You for Choosing 3M

Thank you for choosing 3M multimedia projection equipment. This product has been produced in accordance with 3M's highest quality and safety standards to ensure smooth and troublefree use in the years to come.

For optimum performance, please follow the operating instructions carefully. We hope you will enjoy using this high performance product in your meetings, presentations, and training sessions.

Warranty

Limited Warranty

3M warrants this product against any defects in material and workmanship, under normal usage and storage, for a period of two years from date of purchase. **Exclusion to Warranty:** The lamps are considered a consumable item and are warranted for 90 days or 180 hours, whichever occurs first. Proof of purchase date will be required with any warranty claim. In the event this product is found to be defective within the warranty period, 3M's only obligation and your exclusive remedy shall be replacement of any defective parts (labor included). To obtain warranty service, immediately notify the dealer from which you purchased the product of any defects. In the USA call 1-800-328-1371 for warranty or repair service.

Limitation Of Liability

THE FOREGOING WARRANTY IS MADE IN LIEU OF ALL OTHER WARRANTIES, EXPRESSED OR IMPLIED, AND 3M SPECIFICALLY DISCLAIMS ANY IMPLIED WARRANTY OF MERCHANTABILITY AND FITNESS FOR A PARTICULAR PURPOSE. 3M SHALL NOT BE LIABLE FOR ANY DAMAGES, DIRECT, CONSEQUENTIAL, OR INCIDENTAL, ARISING OUT OF THE USE OR INABILITY TO USE THIS PRODUCT.

Important: The above warranty shall be void if the customer fails to operate product in accordance with 3M's written instructions. This warranty gives you specific legal rights, and you may have other rights which vary from state to state.

FCC STATEMENT - CLASS B: This equipment generates, uses and can radiate radio frequency energy and, if not installed and used in accordance with the instructions, may cause harmful interference to radio communications. However, there is no guarantee that interference will not occur in a particular installation. If this equipment does cause harmful interference to radio or television reception, which can be determined by turning the equipment off and on, the user is encouraged to try to correct the interference by one or more of the following measures:

- Reorient or relocate the receiving antenna.
- Increase the separation between the equipment and receiver.
- Connect the equipment into an outlet on a circuit different from that to which the receiver is connected.
- Consult the dealer or an experienced radio/TV technician for help.

Instructions to Users: This equipment complies with the requirements of FCC (Federal Communication Commission) equipment provided that following conditions are met. The cables (power cord, RGB cable and other cables) may have to be used with the core set to the projector side. Use the cables which are included with the projector or specified.

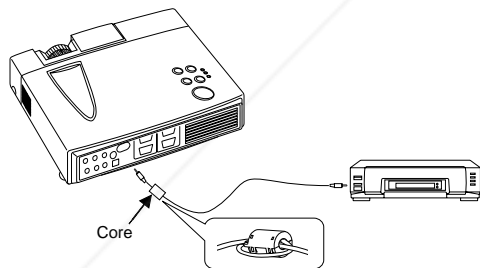

Changes or modifications not expressly approved by the party responsible for compliance could void the user's authority to operate the equipment.

For customers in Canada

NOTICE: This Class B digital apparatus complies with Canadian ICES-003.

Pour les utilisateurs au Canada

AVIS: Cet appareil numérique de la Classe B est conforme à la norme NMB-003 du Canada.

EEC STATEMENT: This machine was tested against the 89/336/EEC (European Economic Community) for EMC (Electro Magnetic Compatibility) and fulfills these requirements.

Video Signal Cables: Double shielded coaxial cables (FCC shield cable) must be used, and the outer shield must be connected to the ground. If normal coaxial cables are used, the cable must be enclosed in metal pipes or in a similar way to reduce the interference noise radiation.

Video Inputs: The input signal amplitude must not exceed the specified level.

Patents, Trademarks & Copyrights

IBM is a registered trademark of International Business Machines Corporation. Apple Macintosh and Apple Powerbook are registered trademarks of Apple Computer, Inc. Microsoft and Windows 95 and Windows 98 are registered trademarks, and Windows and Windows for Workgroups are trademarks of the Microsoft Corporation. Toshiba is a registered trademark of Toshiba Corporation. All other products are trademarks or registered trademarks of their respective companies.

Section 1: Unpack

Contents of Shipping Box

The 3M™ MP8746/MP8747 Personal Projector is shipped with the necessary cables required for standard VCR, PC, Macintosh™ or laptop computer connections. Carefully unpack and verify that you have all of the items shown below. If any of these items are missing, please contact your place of purchase.

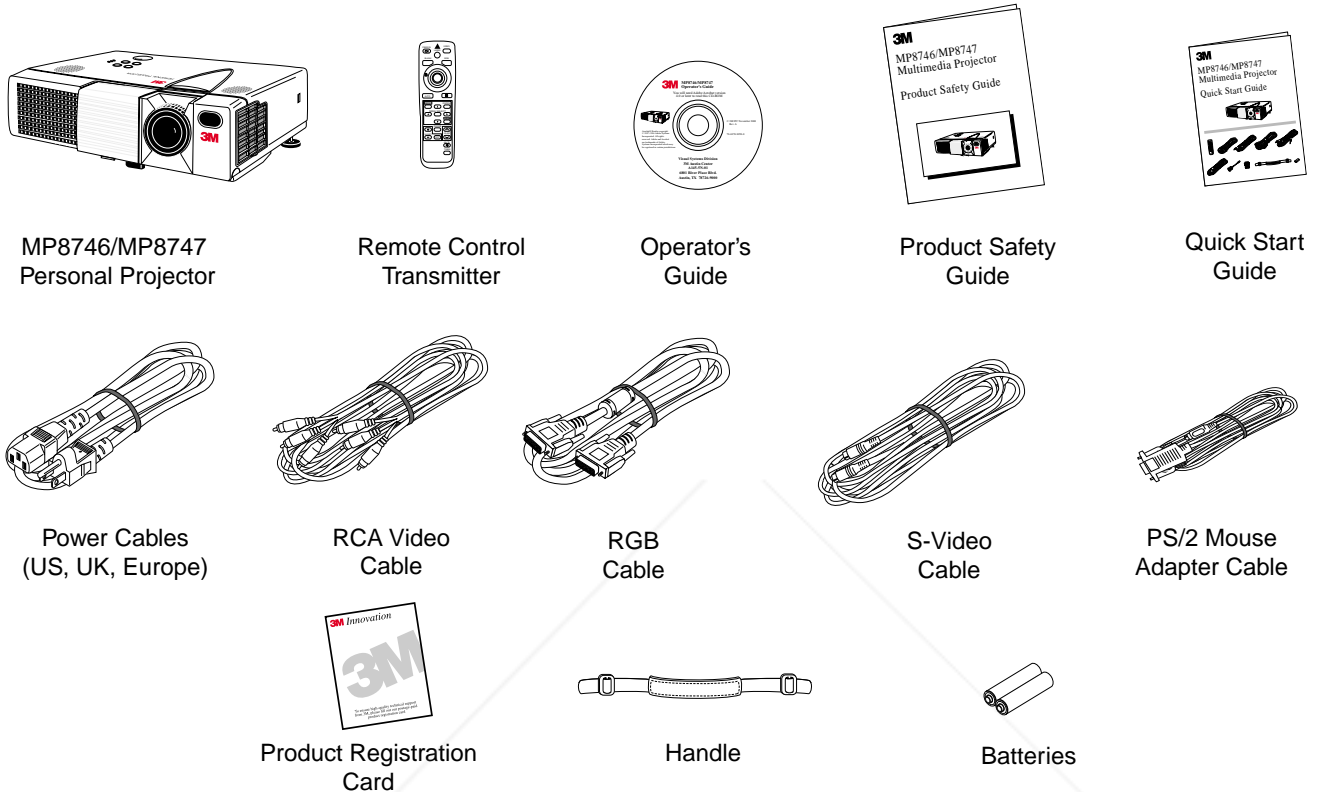

Figure 1.1 Contents of Shipping Box

Optional Accessories

- Serial Mouse Cable (1)
- RS-232 Control Cable (1)
- USB Mouse Cable (1)
- Carrying Case (2)
- Macintosh Adapter (1)
- Stereo Mini-Jack Cable (1)

Keep Your Packing Materials

Save the shipping box and packing materials in the event the MP8746/MP8747 should require shipping to a 3M Service Center for repair.

What's Next?

After you have unpacked the MP8746/MP8747 and identified all the parts, you are ready to set up the projector.

Please read this guide thoroughly before operating your new projector.

Be sure to check our web site (www.3m.com/meetings) regularly for updates and supplemental information. On the CD-ROM, you can link directly to the web site by clicking [here](#) or on "3M Innovation" in the lower right corner of the Main Menu.

Section 2: Product Description

Machine Characteristics

The MP8746/MP8747 Personal Projector integrates ultra-high bright lamp and polysilicon LCD display technology into a single unit. It accepts input from two computer sources and two video/audio sources, and projects a bright, super-crisp image. Switching your presentation from a computer input to a video input, then back to a computer input simply requires the push of a button on the remote control keypad or control panel keypad.

The MP8746/MP8747 Personal Projector offers the following features:

- UHB (ultra-high bright) projection lamp
- XGA resolution (3 separate 1024 x 768 LCD panels are used for the R, G and B signals)
- Intelligent SXGA, VGA, and SVGA scaling
- Compact size, lightweight for portability
- RGB (computer video) output terminal
- Manual zoom and focus functions
- 4x digital magnification
- Easy to set up and use
- Ability to display 16.7 million colors
- Two computer input connections
- Two video input connections (composite and S-video compatible)
- Slim, lightweight remote control
- Eight blank-screen colors available
- Two built-in speakers (1.0 watt)
- Horizontal and vertical image inverting function
- Horizontal and vertical image position control
- Digital keystone correction
- On-screen menu with nine languages
- Universal power supply
- IR sensor in front and rear for maximum remote control range
- RS-232 control capability
- Color balance control for data/video
- Plug & Play compatible
- Freeze function
- Kensington™ Lock slot  (Kensington™ Microsaver needed)
- Aspect ratio 16:9, 4:3, or 4:3 small

✓ *Note: The MP8746/MP8747 is one of the brightest personal projectors in the marketplace. The brightness of your machine will vary depending on the ambient room conditions and contrast/brightness settings.*

 **Discount-Merchant.com (800) 281-8860**
THE TRUSTED SOURCE FOR PROJECTOR LAMPS AND ACCESSORIES

Section 2: Product Description

Part Identification List

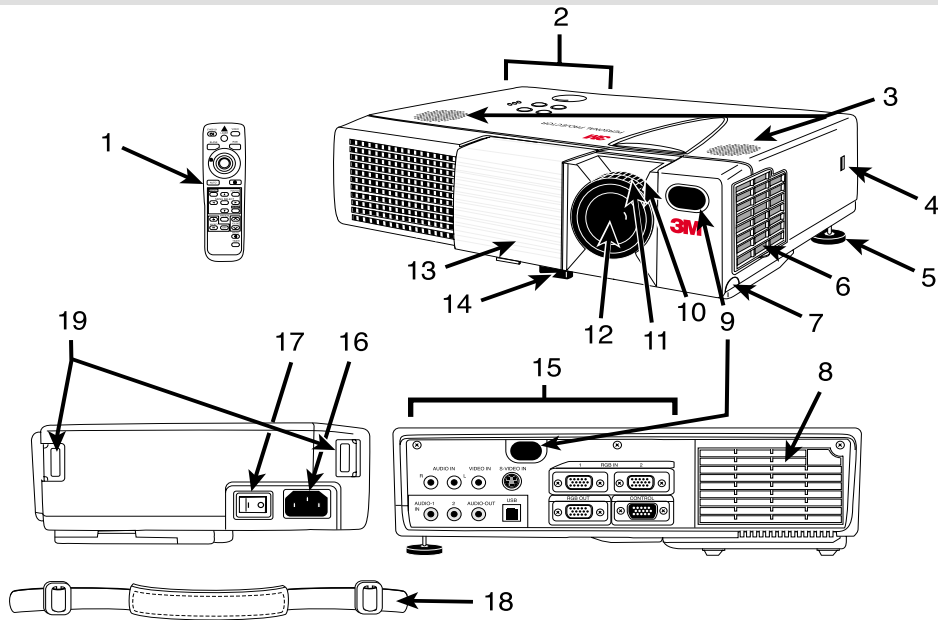

Figure 2.1 Identifying MP8746/MP8747 Parts

- | | |
|---|--|
| <ol style="list-style-type: none"> 1. Remote control transmitter 2. Control panel keypad (see below) <ol style="list-style-type: none"> a) STANDBY/ON button b) ON, LAMP, TEMP indicators c) INPUT, MUTE, RESET buttons d) MENU disk button 3. Stereo speakers 4. Kensington™ Lock slot 5. Tilt adjustment knob 6. Air filter cover and intake 7. Height adjustment foot lock button 8. Cooling fan exhaust 9. Remote control sensors | <ol style="list-style-type: none"> 10. Zoom knob 11. Focus ring 12. Projection lens 13. Sliding lens door 14. Height adjustment foot 15. Terminal connection panel <ol style="list-style-type: none"> a) S-Video, Video, Audio inputs b) RGB inputs c) RS-232C, PS/2, Serial, ADB Control terminals 16. AC power cord connection 17. Main power switch 18. Handle 19. Handle hooks |
|---|--|

Control Panel Keypad Buttons

The control panel keypad is located on top of the projector.

- Press the STANDBY/ON button to turn the projector off and on.
- Press the INPUT button to select the source of the signal to be displayed on the screen. The type of signal will be displayed at the bottom right of the screen.
- Press the MUTE button to turn the audio output off and on.
- Press the RESET button to return the projector to its default settings.
- Press the MENU DISK PAD button to access on-screen menus and select items. (For more information on this feature, see page 19.)



Figure 2.2 Control Panel Keypad Buttons

Section 2: Product Description

System Setup—Connecting to Various Equipment

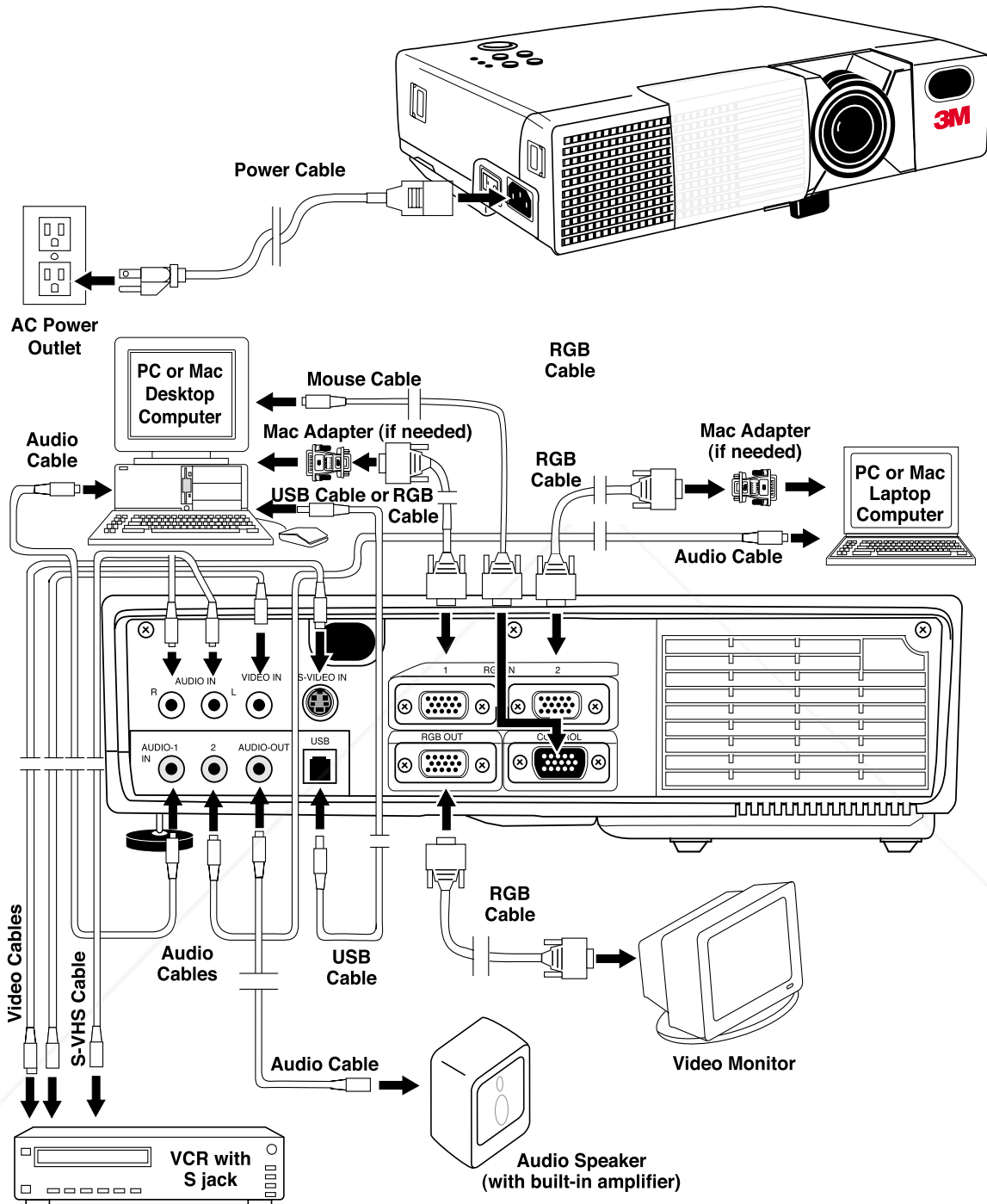

Figure 2.2 Cable Connections

- Turn power off to all devices before making connections. Never plug anything into the projector or computer while any device is in operation.
- The MP8746/MP8747 must be powered down when making connections. The mouse emulation may not work if the unit is not powered down before the mouse cable connections are made.
- Do not use place projector on its side or tilt at an angle greater than 20°.

Caution

Section 2: Product Description

System Setup—Connecting to Various Equipment (continued)

Cable Connections

RGB Signal input (video from computer)

Connect one end of the enclosed RGB cable to the RGB IN 1 or 2 terminal of the projector. Connect the other end to the RGB signal output or RGB OUT of the computer.

✓ **Note:** *For Macintosh computers, the optional Mac adapter is necessary. Please consult your dealer to order one, if necessary. Ordering information is on page 30.*

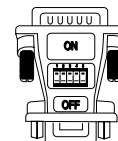

Figure 2.3 Mac Adapter

Audio signal input (from computer)

Connect one end of the optional audio cable to the AUDIO IN 1 or 2 terminal of the projector. Connect the other end to the audio signal output terminal of the computer.

Video signal input (from videotape recorder [VCR] or similar video device)

Connect one end of the enclosed audio/video cable to the VIDEO IN terminal of the projector. Connect the other end to the video signal output terminal of the video device.

S-Video signal input

Connect one end of the optional S-Video cable (with Mini-DIN 4-pin jack) to the S-VIDEO IN terminal of the projector. Connect the other end to the S-Video output terminal of the video device.

Audio signal (from VCR or similar video device)

Connect the ends of the enclosed audio/video cable (with RCA jack) to the AUDIO R and L terminals of the projector. Connect the other ends to the audio output terminal of the video device.

RGB signal output (connecting to a monitor)

Connect one end of the optional RGB cable (with D-Sub 15-pin shrink jack) to the RGB OUT terminal of the projector. Connect the other end to the RGB input terminal of the computer.

Audio signal output (connecting to a speaker)

Connect one end of the optional audio cable (with stereo mini-jack) to the AUDIO OUT terminal of the projector. Connect the other end to the audio input terminal of the computer.

PS/2, ADB, Serial, or RS-232C communication (mouse emulation)

Connect one end of the appropriate mouse cable to the CONTROL terminal of the projector. Connect the other end to the appropriate port (PS/2, ADB, serial, or RS-232C) of the computer. For PS/2 mouse emulation (IBM-compatible computers), use the enclosed PS/2 mouse adapter cable. For other cables, please consult your dealer.

USB communication (mouse control only)

Connect one end of the optional USB cable to the USB jack (B-type) of the projector. Connect the other end to the USB jack (A-type) of the computer.

✓ **Note:** *When connecting laptop computer, set the RGB external image output to valid. See your computer's user manual for more information.*



Caution

- Use only the cables which are included with the projector or are specified.
- Incorrect connection could result in fire or electrical shock.
- Please review this manual and its safety precautions before connecting.

Section 2: Product Description

Remote Control Transmitter Identification

Use the remote control transmitter within a distance of approximately 3 meters (or 9.8 feet) from the sensor of the front of the projector, and within a range of 30° to the left and right. Strong light and obstacles may interfere with operation of the remote control transmitter.

STANDBY/ON

Press STANDBY/ON button to begin projection mode (lamp on) or press and hold button for one second to switch to standby mode (lamp off).

BLANK

Press to turn ON/OFF the screen blanking function.

DISK PAD

Press to operate the mouse shift function and left-click function.

*AUTO

Press to make projector automatically adjust 4 items (V. POSIT, H. POSIT, H. PHASE, and H. SIZE) for RGB input signal. (Please see note at bottom right.)

MENU

Press to turn ON/OFF the menu screen display.

MENU directional arrows

Press to select menu items when the menu screen is displayed. Press to operate the mouse shift function. After the POSITION button has been pressed, press these buttons to move the picture upward, downward, and to the left and right.

*MENU SELECT

Press to display individual menu items. Can also be used to click the left mouse function.

*MAGNIFY

Press to magnify the displayed image. Press (+) to enlarge the center of the image. Press again to enlarge up to 4x magnification. Press (-) to reduce display magnification. (Can also be used with POSITION to select image area to be magnified.)

VOLUME and MUTE

Pressing these at the same time will operate the page-up or page-down function of the USB mouse.

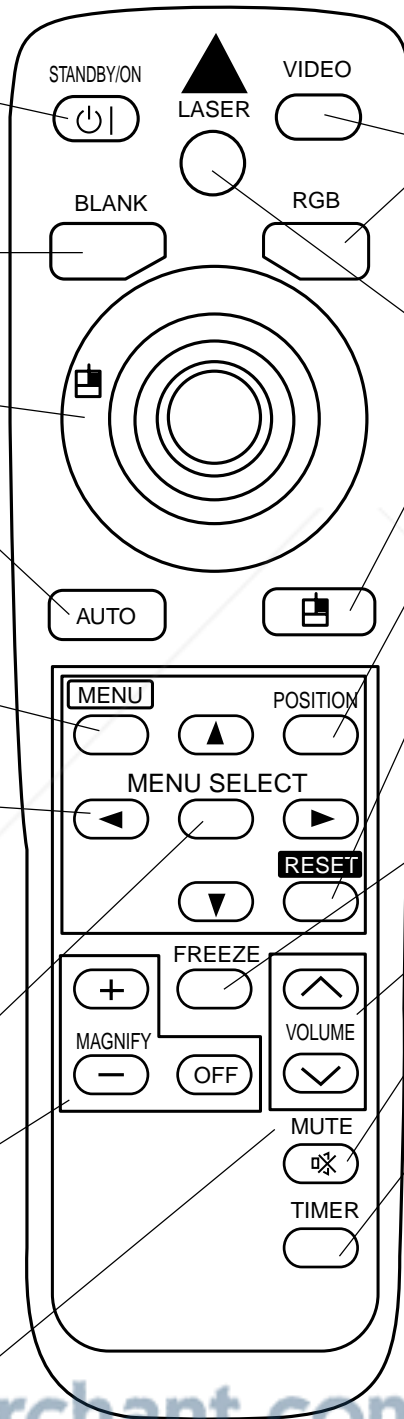

VIDEO and RGB

Press to select the input source. Press again to select the next source.

LASER

Press to turn ON/OFF laser beam pointer.

MOUSE / RIGHT

Press to click the right mouse button.

*POSITION

Press this and any menu directional arrows for corresponding movement of the picture (with RGB signal only).

RESET

Press to return a displayed menu item to its default setting. Press to click right mouse button. Press after scrolling with POSITION to return picture to original position.

*FREEZE

Press to turn ON/OFF the freeze (still) image display.

VOLUME

Press to adjust loudness of sound.

MUTE

Press to stop audio output. Press again to resume audio output.

TIMER

Press to turn ON/OFF the Timer on the Menu screen. (Timer cannot be displayed during Freeze function.)

AUTO ADJUST Notes:

Requires several tens of seconds. May not operate correctly in some cases, depending on the connected computer and its signal and type of image. Execute auto adjust with display of the running application set at maximum. After auto adjust, image may be slightly darker due to automatic adjustment of signal level.

This button will not function if the messages "NO INPUT IS DETECTED" or "SYNC IS OUT OF RANGE" are displayed.

Figure 2.4 Basic Remote Control Transmitter

Section 2: Product Description

Changing Remote Control Battery

When remote control transmitter becomes difficult to operate or does not respond, it usually needs new batteries.

1. Turn over the remote control transmitter to access the battery holder.
2. Push the battery cover tab as indicated and lift up to remove it.
3. Lift old batteries out of compartment.
4. Replace with two AA batteries. Make sure the positive (+) and negative (-) terminals are correctly oriented.
5. Place battery cover back on top and snap down into place.



Figure 2.5 Changing Remote Control Batteries



Caution

- Avoid excessive heat and humidity.
- Do not mix old and new batteries or different types of batteries.
- Remove batteries if remote will not be used for an extended period of time.

Mouse Emulation

Apple™ Desktop Mouse—The Macintosh operating system should recognize the MP8746/MP8747 as a mouse without any drivers being loaded.

VirtualMouse for PC Computer—For IBM™ -compatible computers, the operating systems will need to be set to “Serial Mouse,” “PS/2 Mouse,” or “USB Mouse” to recognize the projector as a mouse pointer device.

Change mouse driver information to “Serial Mouse,” “PS/2 Mouse,” or “USB Mouse.”

- a) **Windows™ 95/Windows™ 98**—Click “Start;” select “Settings;” select “Control Panel.” Click on “Mouse;” select the “General” tab; (see what driver is currently loaded and make note of it); select “Change;” select “Show all devices;” (make note of the current Manufacturer and Model); select “Standard Mouse Type” for Manufacturer; then select “Standard Serial Mouse,” “Standard PS/2 Mouse,” or “USB Mouse.” Click OK to change and apply the new driver. Restart Windows if prompted. *USB mouse emulation is not supported in all versions of Windows™ 95.*
- b) **Windows™ 3.1**—From “Program Manager” click “Main;” then click “Windows Setup;” (make note of what the current mouse driver is). Click “Options;” then “Change Systems Settings.” Choose “Mouse.” It should be listed as “Microsoft or IBM PS/2.” *USB mouse emulation is not supported in Windows™ 3.1.*

Section 2: Product Description

Mouse Emulation (continued)

The mouse type and cable type are determined by the type of computer used. Use the table shown below to select the appropriate cable or refer to your computer's user manual. Connect as shown in the diagram.









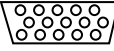

Mouse Type	Accessory Cable	PC Connector	Projector Control/USB Terminal
PS/2	 PS/2 + Serial	MINI-DIN 6P (female) 	D-Sub 15P (female) 
ADB (Mac)	 Mac + Serial	MINI-DIN 4P (female) 	D-Sub 15P (female) 
Serial	 Serial	D-Sub 9P (male) 	D-Sub 15P (female) 
USB	 USB	USB A type (host) 	USB B type (device) 

Figure 2.6 Mouse Connection Table

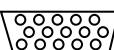
✓ **Note:** *USB, Serial, and ADB mouse cables are optional accessories. Please refer to page 30 for ordering information.*

Remote Control Mouse Function

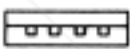
For PS/2, ADB (Mac), Serial

1. Turn off the computer and use the appropriate cable to connect the computer to mouse unit.
2. Turn on the computer and use the mouse function of the remote control. If there are any problems, check the cable connections and reboot the computer.
3. Refer to the remote control instructions on page 12 for more instructions concerning mouse operation.

- Before connecting, read the manual(s) of the equipment being connected.
- Turn off the computer power supply before connection.
- Use only the mouse cable provided.
- In the case of laptop computers with a built-in pointing device (such as a trackball), the device will sometimes have priority even if a mouse is connected. If necessary, disable the device and change the BIOS setting (system setup) so that an external mouse can be selected. Restart the computer after changing the BIOS setting. Refer to the computer manual for more information on this setting.
- Some computers may not have the utility program to operate a mouse. Refer to the computer hardware manual.

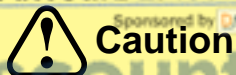

Caution

Section 2: Product Description

Remote Control Mouse Function (continued)

For USB

1. Use the enclosed USB cable to connect the computer to the mouse unit. Turn on the computer power before or after connecting the USB cable.
2. When this mouse is connected for the first time, a message may appear on the screen concerning the installation of USB software. Follow the instructions on the screen and install suitable software.
3. If there are still problems, reconnect the cables.
4. Refer to the remote control instructions on page 12 for more instructions concerning mouse operation.



Caution

- Before connecting, read the manual(s) for equipment being connected.
- Use only the designated USB cable to connect.
- Effective with USB only when the mouse is used.
- Do not use with any device other than a personal computer.
- If using Windows 95, it is necessary to set it so that USB can be used with version OSR 2.1 or higher. Depending on the kind or version of the host controller, operation may not be possible in some cases.
- Some computers may not have the utility program to operate a mouse. Refer to the computer hardware manual.

Attaching the Handle

Attach the enclosed handle to the projector for easier carrying and portability.

1. Raise the handle hooks on the right side of the projector.
2. Insert one end of the handle strap through the handle hook.
3. Thread the end of the strap through the buckle as shown.
4. Repeat for the opposite end of the handle strap.

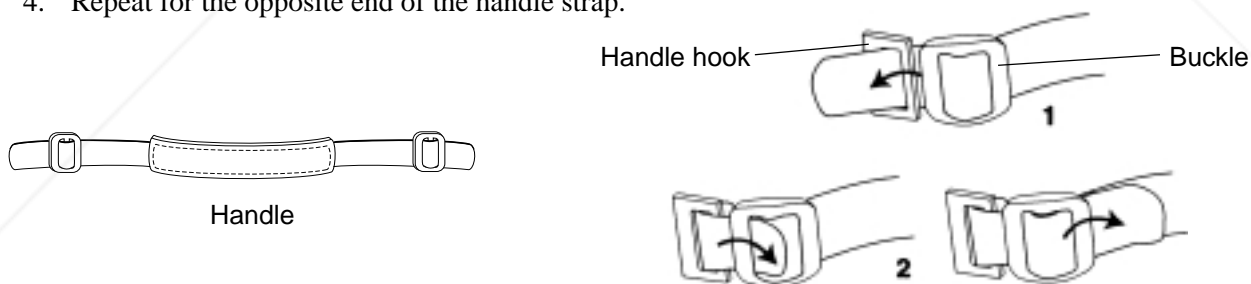

Figure 2.7 Handle and How to Attach



Caution

- Make sure the handle is securely attached before lifting or carrying. If the handle is not secure, it may drop the projector.
- If the projector is dropped, take it to a service center for inspection and repair before using again. Using a dropped projector can cause malfunctions that could result in fire and electrical shock.
- Do not swing or hang the projector by the handle.

Section 3: Basic Operations

Projector Start-up

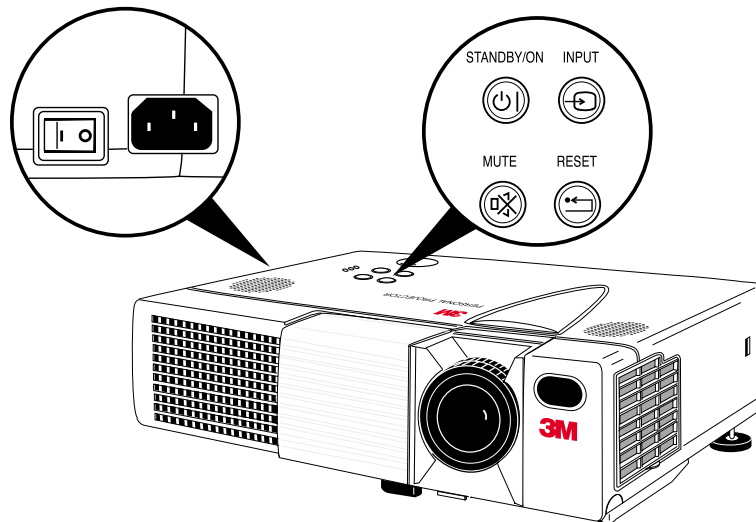







Figure 3.1 Projector Controls

1. Make all equipment and cable connections with the power off.
2. **Turn on the MAIN POWER SWITCH**  of the projector. The ON indicator will light up orange.
3. **Press the STANDBY/ON button** . The ON indicator will blink green during warm-up and lamp ignition, then stay green to indicate correct operation. When power is turned off, there is a 60-second reset period before the STANDBY/ON button will function again.
4. **Turn on all connected equipment.** (Refer to “System Set-up—Connecting to Various Equipment,” page 10.)
5. Open sliding lens door.
6. Press the INPUT button  on the projector or the INPUT SELECT (VIDEO or RGB) button on the remote control transmitter to select the source of the signal to be projected on the screen. The selected signal input is displayed at the bottom right of the screen. The display will show the last selected input source before power was turned off.
7. Adjust picture size using the projection lens Zoom knob. Adjust focus using the projection lens Focus ring.

Projector Shutdown

1. **Press and hold the STANDBY/ON button**  **for approximately two seconds.** The ON indicator blinks orange and the lamp turns off. After approximately one minute, the fan stops and the indicator stays orange.
2. Turn off the **MAIN POWER SWITCH.** 
3. Close the sliding lens door.



Caution

- Do not turn off the POWER SWITCH before pressing the STANDBY/ON button. After the STANDBY/ON button is pressed, the fan rotates for about one minute to cool the projector.
- If the projector is connected to a computer or video device, turn computer or video device off before turning the projector on or off.
- If using RS-232C connection, turn on the computer before turning on the projector.

Section 4: Adjustments and Functions

How to Use Height Adjustment Foot

Adjust the image elevation and projection angle (within 0 to 9°) using the height adjustment foot at the front of the projector and the tilt adjustment knob at the rear of the computer.

1. Raise the front end of the projector so the foot is not touching the tabletop.
2. Push the lock button on the left side of the projector to unlock the foot.
3. Extend or retract the foot to the desired height.
4. Release the lock button to lock the foot into position.
5. For finer adjustment, rotate the tilt adjustment knob on the left rear foot of the projector.



Caution Do not unlock the foot adjuster if the projector is not supported.

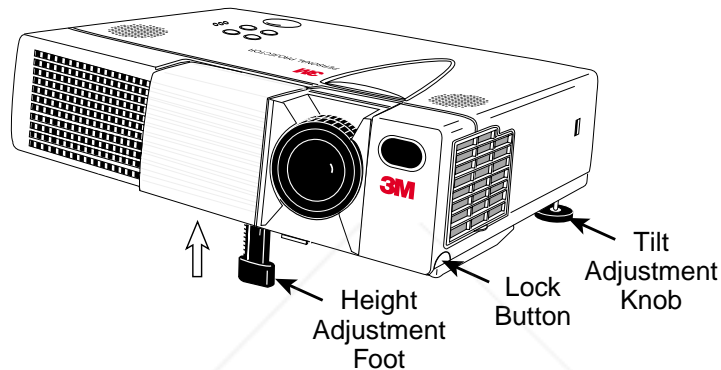

Figure 4.1 Height Adjustment

Screen Chart

Place the projector at the recommended distance from the screen, according to the desired image size in the chart below.

a = distance from the projector to the screen

The distances shown in the chart are for full size (1024 x 768).

Screen Size			Distance to Screen	
Width	Height	Diagonal	Minimum	Maximum
81.2 cm (32 in.)	60.9 cm (24 in.)	101.6 cm (40 in.)	165.1 cm (5.0 ft.)	198.1 cm (7.0 ft.)
121.9 cm (48 in.)	91.4 cm (36 in.)	152.4 cm (60 in.)	248.9 cm (8.0 ft.)	297.2 cm (10.0 ft.)
162.5 cm (64 in.)	121.9 cm (48 in.)	203.2 cm (80 in.)	332.7 cm (11.0 ft.)	398.8 cm (13.0 ft.)
203.2 cm (80 in.)	152.4 cm (60 in.)	254 cm (100 in.)	414.0 cm (14.0 ft.)	497.8 cm (16.0 ft.)
243.8 cm (96 in.)	182.8 cm (72 in.)	304.8 cm (120 in.)	497.8 cm (16.0 ft.)	599.4 cm (20.0 ft.)
304.8 cm (120 in.)	228.6 cm (90 in.)	381.0 cm (150 in.)	624.8 cm (21.0 ft.)	749.3 cm (25.0 ft.)
406.4 cm (160 in.)	304.8 cm (120 in.)	508 cm (200 in.)	833.1 cm (27.0 ft.)	1000.8 cm (33.0 ft.)

Figure 4.2 Screen Angles and Screen Chart

✓ **Note:** These sizes are $\pm 10\%$, due to variations in the manufacture of the lens. If you are close to an endpoint, you should verify that the image is the proper size (1024 x 768) and at the proper distance.

For your own customized screen chart, please click [here](#) (on the CD-ROM) or visit our Projector to Screen Calculator on the 3M web site (www.3m.com/meetings/screen/7630_calc.html).

Section 4: Adjustments and Functions

Plug & Play Function

Plug & Play is a system configured with peripheral equipment (including a computer and display), and a compatible operating system. This allows the user to connect various peripheral equipment successfully without having to adjust settings manually. The equipment and projector exchange this information automatically. This projector is VESA DDC (Display Data Channel) 1/2B compatible. Plug & Play is possible by connecting to a computer that is VESA DDC compatible.

✓ **Note:** *Use the RGB cable included with this projector when using plug & play. With other cables, pins (12) - (15) are sometimes not connected (effective only for RGB 1 terminal).*

Freeze Function

The Freeze function is used to display (freeze) a single frame of the image being projected. This function can be used with the Magnify function to freeze the image and then enlarge (magnify) part of the image to view it in greater detail. Press the FREEZE button repeatedly to engage or disengage this function.

✓ **Note:** *The FREEZE function will turn off during the operation of the MENU, VOLUME, MUTE, BLANK, TIMER, AUTO or POSITION functions.*

Magnify Function

The Magnify function is used to enlarge a portion of the projected image. Press the MAGNIFY (+) button to magnify the center of the displayed image. Press again to magnify up to 4x. Press the MAGNIFY (-) button to reduce image size. Press OFF to return to normal image size.

Position Function

To move the display area being magnified, press the POSITION button, then use the menu directional arrow buttons to move the magnified area up, down, left or right.

✓ **Note:** *To return to normal display, press the MAGNIFY OFF button. The MAGNIFY function will turn off during the operation of the KEYSTONE or AUTO functions.*

Input Select Function

To change the input signal being received by the computer, select RGB1, RGB2, VIDEO, or S-VIDEO. The selected signal name is displayed for approximately three seconds when the input signal is changed.

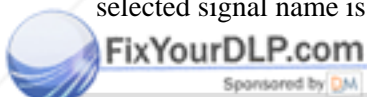

Reset Function

To restore an item to its default (initial) setting, select the item and press the RESET button. For position adjustment, press the RESET button and the POSITION button. (Valid only with RGB signal input.) RESET function is not valid in VOLUME, LANGUAGE, or H. PHASE items. The RESET button may also operate as a mouse control button.

Section 4: Adjustments and Functions

Menu Navigation

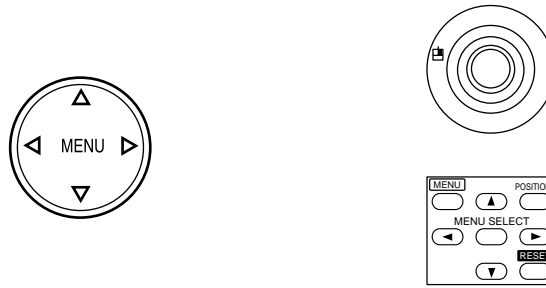

Figure 4.3 Menu Disk button on projector and Menu buttons from basic remote control transmitter

1. **Press MENU DISK button on projector or remote control MENU buttons.**
On-screen menus are displayed on the projected image.
2. **Select the menu to be adjusted by pressing the right or left arrows on the MENU DISK buttons or the remote control.**
Selected Menu is then highlighted.
3. **Select the menu item to be adjusted by pressing the up or down arrows on the MENU DISK button or on the remote control.**
Highlighted items may be adjusted.

✓ **Note:** *Separate settings are provided for the VIDEO and RGB input terminals. Adjustments are saved after shutdown.*

Press MENU SELECT on the remote control to view the full menu or just the selected menu item. When only the selected menu item is displayed, the other menu items are displayed by pressing the up or down arrows on the Menu buttons.



Figure 4.4 Single Selected Menu Item.

Factory Default Setting:

To reset a single item from SETUP menu:

1. Select the adjustment item (Bright, Contrast...).
2. Press the RESET button. **Only the selected item**

resets
FixYourSLP.com
Sponsored by DM

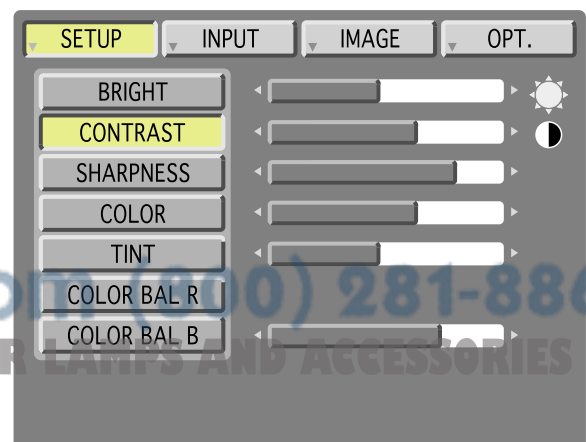

Figure 4.5 Default Settings

Section 4: Adjustments and Functions

SETUP Submenu

The SETUP sub-menu is used to adjust and move the image position. The projector will display either the RGB (Figure 4.6) or Video (Figure 4.7) submenu, according to the input source being projected.

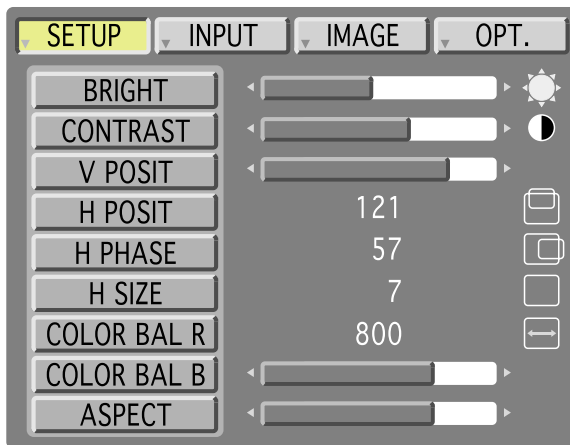

Figure 4.6 RGB signal input

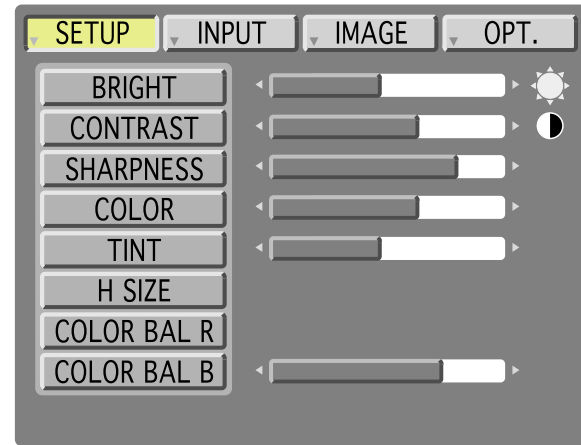
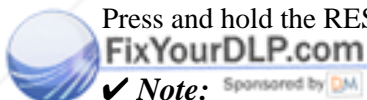

Figure 4.7 Video signal input

Adjustment Item	Details of Adjustment	Freeze On	Magnify On	Both On
BRIGHT (BRIGHTNESS)	Dark ← → Bright	Adjustable	Adjustable	Adjustable
CONTRAST	Lower ← → Higher	Adjustable	Adjustable	Adjustable
V.POSIT (V.POSITION)	Moves the picture up or down.*	Not Adjustable	Not Adjustable	Not Adjustable
H.POSIT (H.POSITION)	Moves the picture left or right.*	Not Adjustable	Not Adjustable	Not Adjustable
H.PHASE	Decreases the picture flicker.*	Not Adjustable	Adjustable	Not Adjustable
H.SIZE	Widens or Narrows the horizontal size of picture.*	Not Adjustable	Not Adjustable	Not Adjustable
SHARPNESS	Soft ← → Sharp	Not Adjustable	Adjustable	Not Adjustable
TINT	Red ← → Green	Not Adjustable	Adjustable	Not Adjustable
COLOR	Less ← → More	Not Adjustable	Adjustable	Not Adjustable
COLOR BAL R	Less red ← → More red	Adjustable	Adjustable	Adjustable
COLOR BAL B	Less blue ← → More blue	Adjustable	Adjustable	Adjustable
ASPECT	4:3, 4:3 small, 16:9	Not Adjustable	Not Adjustable	Not Adjustable

***Auto Sync Function:** Press the AUTO button on the remote control to engage the automatic sync function. The message “AUTO IN PROGRESS” will display for several seconds as the projector adjusts the V. POSIT, H.POSIT., H.PHASE, and H. SIZE settings. Auto Sync can also be executed from the control panel key pad. Press and hold the RESET button, then press the INPUT button.



✓ Note: Sponsored by DJI

- **TINT cannot be adjusted with a PAL or M-PAL video signal input.**
- **TINT, COLOR, and SHARPNESS cannot be adjusted with an RGB signal input.**
- **V. POSIT, H. POSIT, H. PHASE, and H. SIZE cannot be adjusted with a VIDEO signal input.**
- **Menu operation is not possible during Freeze functions.**
- **Displaying the SETUP submenu will cancel the Magnify and Freeze functions.**

Section 4: Adjustments and Functions

INPUT Submenu

The INPUT submenu is used to select the RGB or video input source. The RGB values are shown in Figure 4.8. The Video values are shown in Figure 4.9.



Figure 4.8 RGB Input Submenu

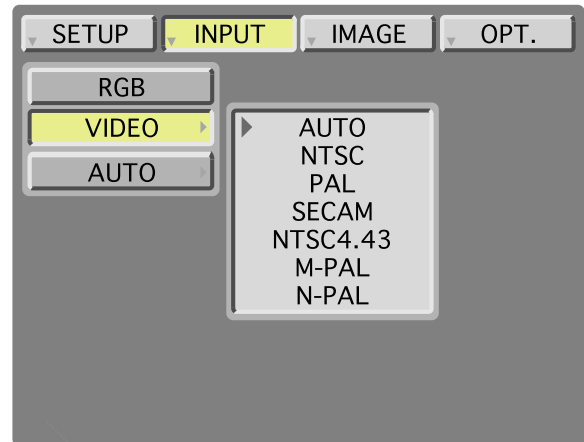

Figure 4.9 Video Input Submenu

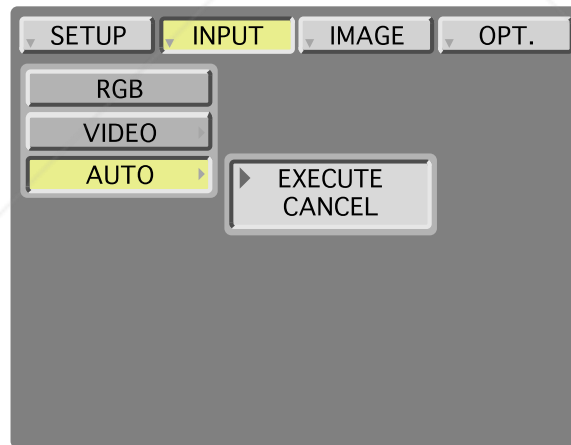

Figure 4.10 Auto Input Submenu

Adjustment Area	Value
RGB	Displays the following RGB inputs: FH: horizontal sync frequency FV: vertical sync frequency
Video	Selects the VIDEO signal format Auto, NTSC, PAL, SECAM, NTSC 4.43, M-PAL, N-PAL
Auto	Selects EXECUTE or CANCEL for Auto signal input detection.

Section 4: Adjustments and Functions

IMAGE Submenu

The IMAGE submenu is used to change the image characteristics.

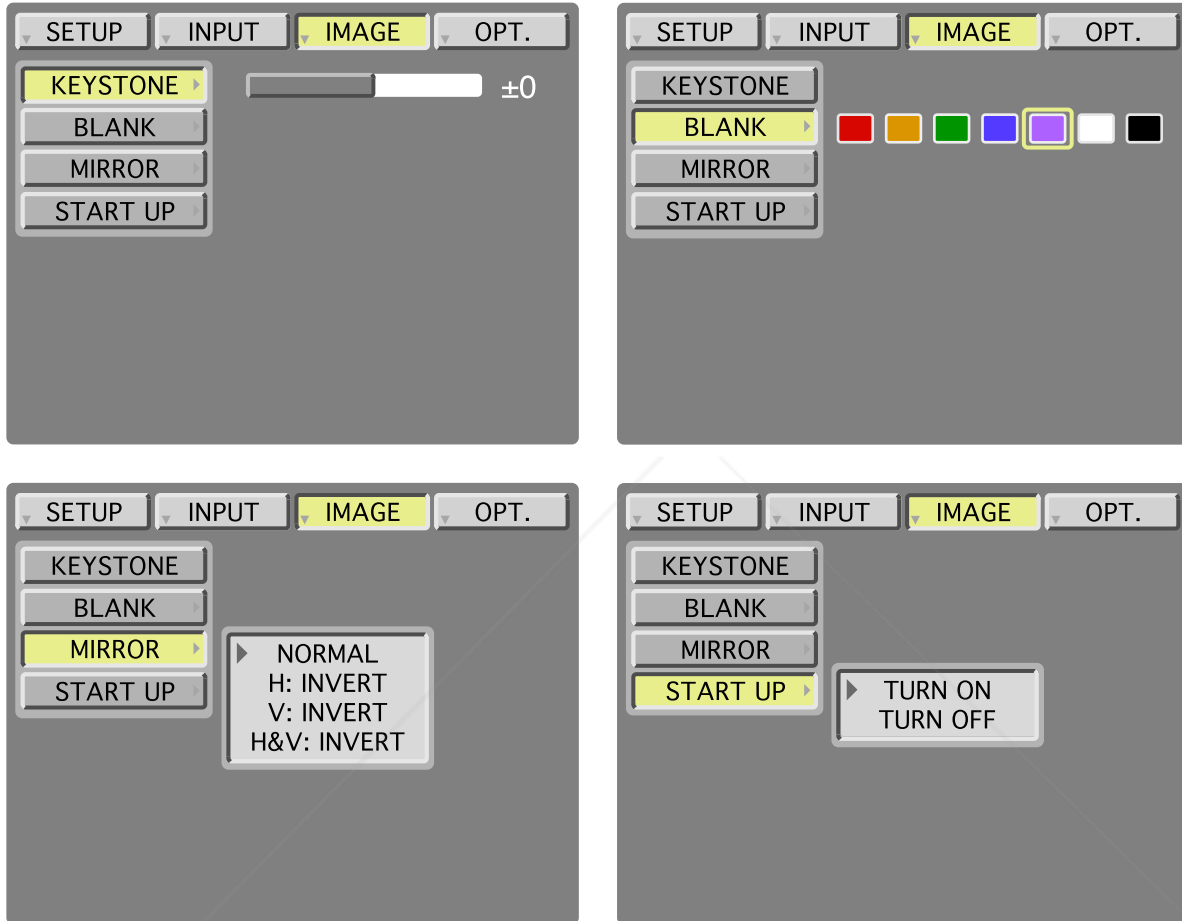

Figure 4.11 Image Adjustment Screens

Adjustment Screen	Value
KEYSTONE	Reduce distortion at bottom of image. \longleftrightarrow Reduce distortion at top of image.
BLANK	Selects the blank screen color: red, orange, green, blue, purple, white or black.
MIRROR	Inverts the picture horizontally or vertically. H: INVERT Inverts the picture horizontally. V: INVERT Inverts the picture vertically. H&V: INVERT Inverts the picture horizontally and vertically.
STARTUP	Enable / Disable startup screen. When canceled, the background color will change to blue.

Section 4: Adjustments and Functions

OPT. Submenu

The OPT. submenu allows you to control communication function.

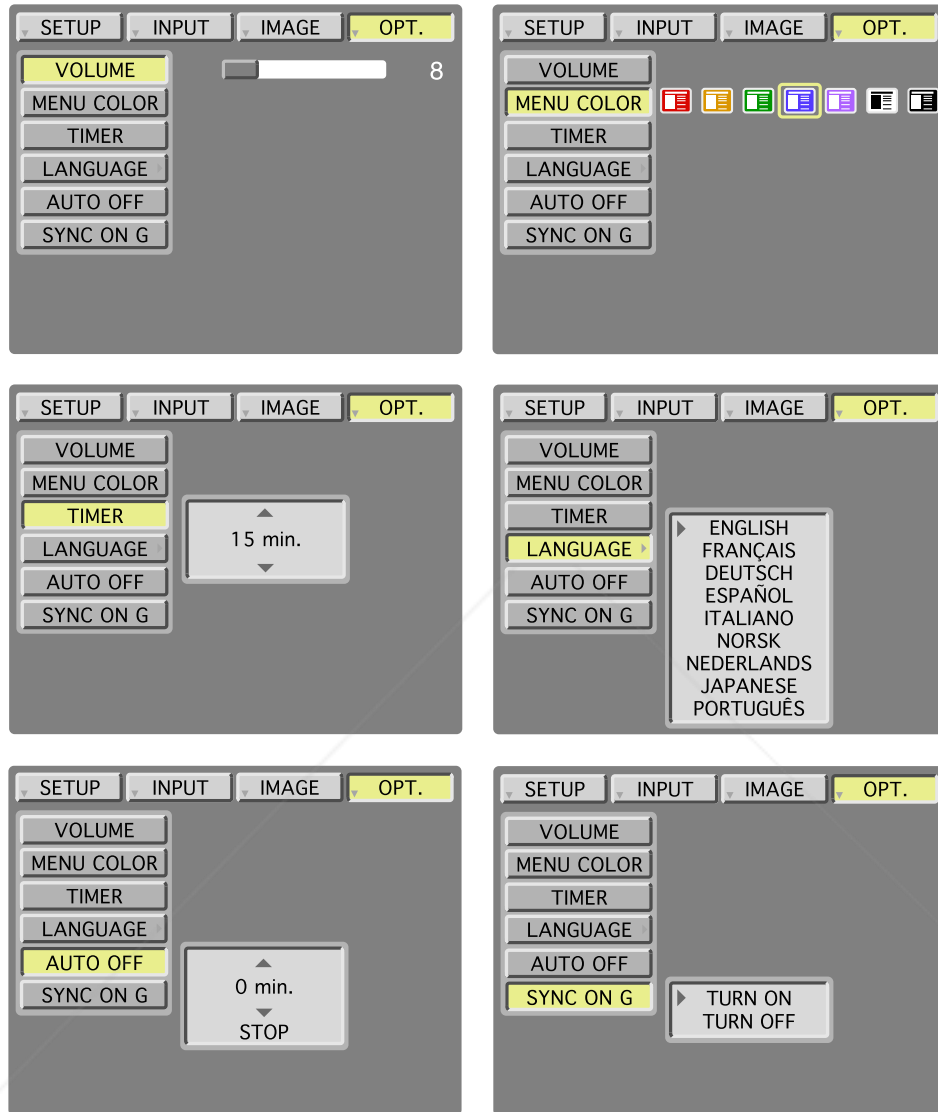

Figure 4.12 OPT Adjustment Screens

Adjustment Screen	Value	Default
VOLUME	Adjusts the loudness of audio coming through the speaker.	8
MENU COLOR	Selects the background color in which the menu system will be displayed. Choice of red, orange, green, blue, purple, white and black. (All menus have white text except white menu, which will have black.)	Blue
TIMER	Sets the timer (0-15 minutes).	—
LANGUAGE	Selects the language on-screen menu. (English, French, German, Spanish, Italian, Norwegian, Netherlands, Japanese, and Portuguese)	—
AUTO OFF	Selects how long projector will stay on in minutes, if no input is detected. Select 0 to disable this function.	—
SYNC ON G	Sets the SYNC on G function to ON/OFF (for older Apple computers).	—

Section 5: Maintenance

Cleaning the Air Filter

✓ **Note:** Clean the air filter about every 100 hours or if the message “CHECK AIR FLOW” is displayed on the screen. If air is restricted due to dust accumulation on filter, the projector may overheat and shut down automatically.

Turn off the **MAIN POWER SWITCH** of the projector and pull out power cord. Let cool for 20 minutes. Vacuum dust and dirt from filter. If the filter cannot be cleaned and needs to be replaced, please consult your dealer.

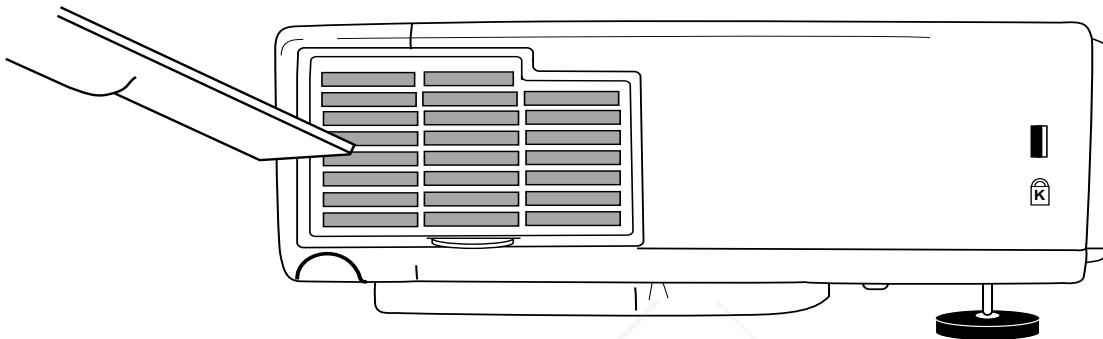

Figure 5.1 Cleaning Air Filter

Cleaning the Inner Components

For safety reasons, have your dealer check and clean inside the projector every two years. (Cleaning it yourself can be hazardous.)

Cleaning the Lens

Gently wipe the lens with lens cleaning paper. Do not touch the lens with your hands.

Cleaning the Projector Case and Remote Control Transmitter

Gently wipe with a soft cloth. If necessary, slightly dampen cloth with water and/or a neutral detergent. Wipe dry with a soft, clean cloth.



Caution

- Turn off the power and remove power cord from outlet before beginning any maintenance work.
- Do not use projector without air filter.
- Do not use harsh detergents or chemicals (like benzene or thinners).
- Do not use cleaning sprays.

Section 6: Lamp

Lamp

The following symptoms may indicate that the lamp needs to be replaced:

- LAMP indicator lights up red.
- “CHANGE THE LAMP” message appears on the screen.

Display Lamp Operation Hours

To determine the lamp operation hours:

1. While the projector is running, press and hold the TIMER button on the remote control for three seconds.
2. The operating time of the lamp will be displayed at the bottom of the screen. The message “CHANGE THE LAMP, AFTER REPLACING LAMP RESET THE LAMP TIMER” will appear after the lamp has reached the end of the normal lamp life. The message “POWER WILL TURN OFF AFTER **20** HOURS” will appear when 20 or less lamp hours remain. The number of hours left until shutdown will decrease until **0** hour is reached, then power will turn off automatically.

✓ **Note:** *After normal lamp operating time has expired, the projector will only run for 10-minute intervals when restarted until the lamp is replaced and the lamp timer is reset. The message “CHANGE THE LAMP” will blink at projector startup to remind you to change the lamp.*

Reset Lamp Hours

The lamp operation hours must be reset after changing the lamp. When the lamp has been replaced after the LAMP indicator is red, or the CHANGE THE LAMP” message is displayed, you must complete the following within 10 minutes after switching on the power. Otherwise, the power will automatically shut down after 10 minutes.

1. To display the total lamp hours, press the RESET button on the projector or the TIMER button on the remote control and hold for three seconds. The “LAMP xxxx hr” message will display at the bottom of the screen.
2. To reset the lamp timer, press the RESET button on the projector or MENU button on the remote while the lamp hours are displayed. The lamp hour reset message will display. Use the left-arrow button on the remote control or the Menu Disk Pad button on the projector to select 0, and wait until the timer display has cleared.



Discount-Merchant.com (800) 281-8860
THE TRUSTED SOURCE FOR PROJECTOR LAMPS AND ACCESSORIES

Section 6: Lamp

Replacing the Lamp



WARNING

To reduce the risk of electrical shock, always turn off projector and disconnect power cord before changing lamp.

✓ **Note:** For maximum lamp life, do not shock, handle or scratch the lamp glass when it is hot. Do not use an old or previously used lamp as a replacement lamp.

1. **Remove lamp access door:** The lamp access door is located on the bottom of the machine. Use a flat-head screwdriver to remove the two screws from the lamp access door. Lift off the lamp access door and set it aside.

2. Use the screwdriver to remove the lamp module retaining screws.

✓ **Note:** These screws are self-containing screws that cannot be removed from the lamp module or access door.

3. **Remove lamp module:** Carefully slide the lamp module out by pulling straight up on the retaining wire on top of the module.

4. **Insert lamp module:** Carefully insert the new lamp module by sliding it straight down into the opening. Ensure that it is fully seated. Reinsert and tighten the lamp module retaining screws to secure the lamp module in place.

5. Insert the hinge tabs on the bottom of the lamp access door, and close. Reinsert and tighten the two screws to secure the lamp access door.

✓ **Note:** Reset the lamp operation hours. See the previous page for details.

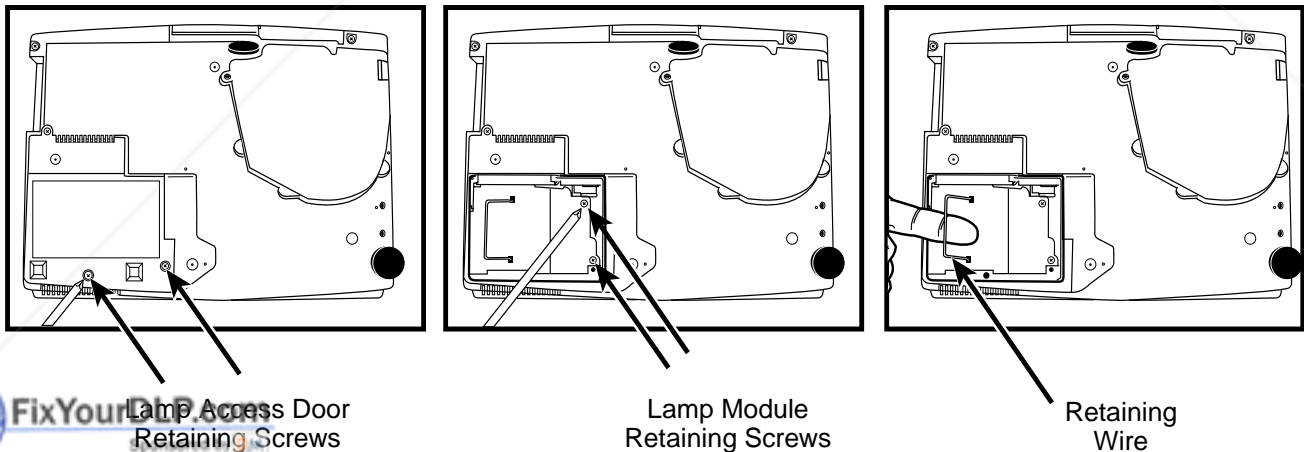

Figure 6.1 Changing Lamp Module



Caution

This lamp contains mercury. Consult your local hazardous waste regulations and dispose of this lamp in the proper manner.

Section 7: Troubleshooting

Symptoms/Solutions

Symptom	Cause	Solution
Power cannot be turned on.	<ul style="list-style-type: none"> • MAIN POWER switch is not turned on. • The power cord is disconnected. • 60 seconds have not elapsed since the power was turned off. 	<ul style="list-style-type: none"> • Turn the MAIN POWER switch on. • Insert the power cord into an AC socket. • Wait 60 seconds before turning on power.
No picture or sound.	<ul style="list-style-type: none"> • The setting of the input source is not correct. • RGB/Video/Audio wiring to projector is not correct. 	<ul style="list-style-type: none"> • Set the correct input using the input select button of the projector or the remote control. • Connect the cable to correct input/output source.
Sound is heard without picture.	<ul style="list-style-type: none"> • RGB/Video/Audio wiring to projector is not correct. • The brightness is set fully to dark. • Lens cap is on. 	<ul style="list-style-type: none"> • Connect the cable to correct input/output source. • Press the MENU button and increase BRIGHTNESS. • Remove lens cap.
Picture is displayed without sound.	<ul style="list-style-type: none"> • Audio wiring to projector is not correct. • The volume is set to minimum. • The volume is muted. 	<ul style="list-style-type: none"> • Connect the cable to correct input/output source. • Press the VOL button to increase Volume. • Press the MUTE button.
Color is weak and tint is incorrect.	<ul style="list-style-type: none"> • The color and tint have been adjusted incorrectly. 	<ul style="list-style-type: none"> • Adjust the color and tint correctly.
Picture is dark.	<ul style="list-style-type: none"> • The brightness and contrast has not been adjusted correctly. • The lamp needs to be replaced. 	<ul style="list-style-type: none"> • Adjust the brightness and contrast correctly. • Replace the lamp with a new one.
Picture is not clear.	<ul style="list-style-type: none"> • Projector is out of focus. 	<ul style="list-style-type: none"> • Adjust the focus and H. PHASE.
LAMP indicator lights red.	<ul style="list-style-type: none"> • Lamp will not ignite. • Temperature inside projector is too hot. 	<ul style="list-style-type: none"> • Turn off power and let cool for 20 minutes, then restart. • If problem persists call your dealer. • Check and clear blocked ventilation holes. • Check and clean air filter.
LAMP indicator blinks red.	<ul style="list-style-type: none"> • Lamp access door on bottom of case is open. • The lamp usage has reached maximum operating hours. 	<ul style="list-style-type: none"> • Ensure lamp access door is closed. • Replace the lamp.
TEMP indicator blinks red.	<ul style="list-style-type: none"> • Cooling fan not operating. 	<ul style="list-style-type: none"> • Contact your dealer.



Discount-Merchant.com (800) 281-8860
THE TRUSTED SOURCE FOR PROJECTOR LAMPS AND ACCESSORIES

Section 7: Troubleshooting

Messages/Solutions

Error Message Displays	Cause	Solution
NO INPUT IS DETECTED ON **	The projector is not detecting a signal.	Check cable connections to input device. If input device not connected to this input mode, switch to next mode.
SYNC IS OUT OF RANGE ON **	The horizontal frequency of input signal exceeds projector capability.	Switch projector to correct resolution. See Appendix.
CHANGE THE LAMP. AFTER REPLACING LAMP, RESET THE LAMP TIME.	Nearing end of normal lamp operating time.	Change the projector lamp and reset the lamp operation hours to zero. The message clears automatically after 3 minutes, and appears each time power is turned on until lamp is changed.
CHANGE THE LAMP. AFTER REPLACING LAMP, RESET THE LAMP TIME. THE POWER WILL TURN OFF AFTER ** HR.	Remaining lamp operation time = 20 hours or less. *Indicates number of hours until power turns off automatically.	Change the projection lamp and reset the lamp operation hours to zero. The message clears automatically after 3 minutes, and appears each time power is turned on until lamp is changed.
CHANGE THE LAMP. (blinking)	Normal lamp operating time has expired. Safety feature shuts projector down after 10 minutes.	Change the projector lamp and reset the lamp operation hours to zero.
CHECK THE AIR FLOW.	The internal temperature has risen.	Switch power OFF and let projector cool for 20 minutes. Check the following and switch ON again. <ul style="list-style-type: none"> • Are ventilation openings dirty or blocked? • Is air filter dirty or blocked? • Is ambient temperature over 35°C (95°F)?



Discount-Merchant.com (800) 281-8860
THE TRUSTED SOURCE FOR PROJECTOR LAMPS AND ACCESSORIES

Section 7: Troubleshooting

Indicator Lights

POWER Indicator Light	LAMP Indicator Light	TEMP Indicator Light	Meaning
Lights orange	Turns off	Turns off	Standby status
Blinks green	Turns off	Turns off	Warming up. Wait.
Lights green.	Turns off.	Turns off.	Operation status.
Blinks orange.	Turns off.	Turns off.	Cool down.
Lights red.	Lights red.	Turns off.	The lamp does not light. Wait approx. 20 minutes before turning on power again. If indicator still lights, the lamp may have failed. Replace lamp.
Lights red.	Blinks red.	Turns off.	A lamp has not been inserted or the lamp cover is missing. Turn off projector, disconnect power and wait 45 minutes for projector and lamp to fully cool. Replace lamp and/or lamp cover door, then re-connect power and turn on projector again.
Lights red.	Turns off.	Blinks red.	The cooling fan is not operating. Switch power off, and wait for 20 minutes until the equipment cools. Check to see if air filter or ventilation openings are blocked. Clear any obstructions.
Lights red.	Turns off.	Lights red.	Internal overheating. Turn off projector, disconnect power, and let cool for 20 minutes. Check to see if air filter or ventilation openings are blocked. Clear any obstructions.

Section 7: Troubleshooting

Service Information

For product information, product assistance, service information, or to order accessories, please call:

- In U.S. or Canada: **1-800-328-1371**
- In other locations, contact your local 3M sales office.

Section 8: Accessories

Accessories

	Part Number
UHB lamp module, 160 W	78-6969-9260-7
Power cable (US)	DY-0205-1356-9
Power cable (UK)	DY-0205-1355-1
Power cable (Germany)	DY-0205-1354-4
VGA cable	78-8118-8611-4
RCA video/audio cable	78-8118-3234-0
Remote Control	78-8118-8652-8
S-VHS video cable	78-8118-3238-1
PS/2 mouse adapter cable	78-8118-3424-7

Not Included with Basic Packet

	Part Number
Ceiling mount	78-6969-9261-5
Adjustable height suspension	78-6969-8312-7
Shipping case	78-6969-9259-9
Soft carry case	78-6969-9203-7
Deluxe leather carry case	78-6969-9144-3
RS-232 control cable	78-8118-3312-4
USB mouse cable	78-8118-8186-7
Mac adapter	78-8118-3308-2
Stereo mini jack cable	78-8118-8290-7

How to Order

Please order these parts through your dealer, or contact 3M Customer Service at the following number:

- In U.S. or Canada: **1-800-328-1371**
- In other locations, contact your 3M sales office.



FixYourDLP.com
Sponsored by 3M

The contents of this manual are subject to revision without prior notice.

3M assumes no responsibility for the infringement of special rights of a third party or other rights that may arise out of the information contained in this manual.

Reproduction of this manual in any form without prior permission is strictly prohibited.

3M will replace the manual if any pages are missing or collated incorrectly.

Technical Appendix

Dimension Diagram

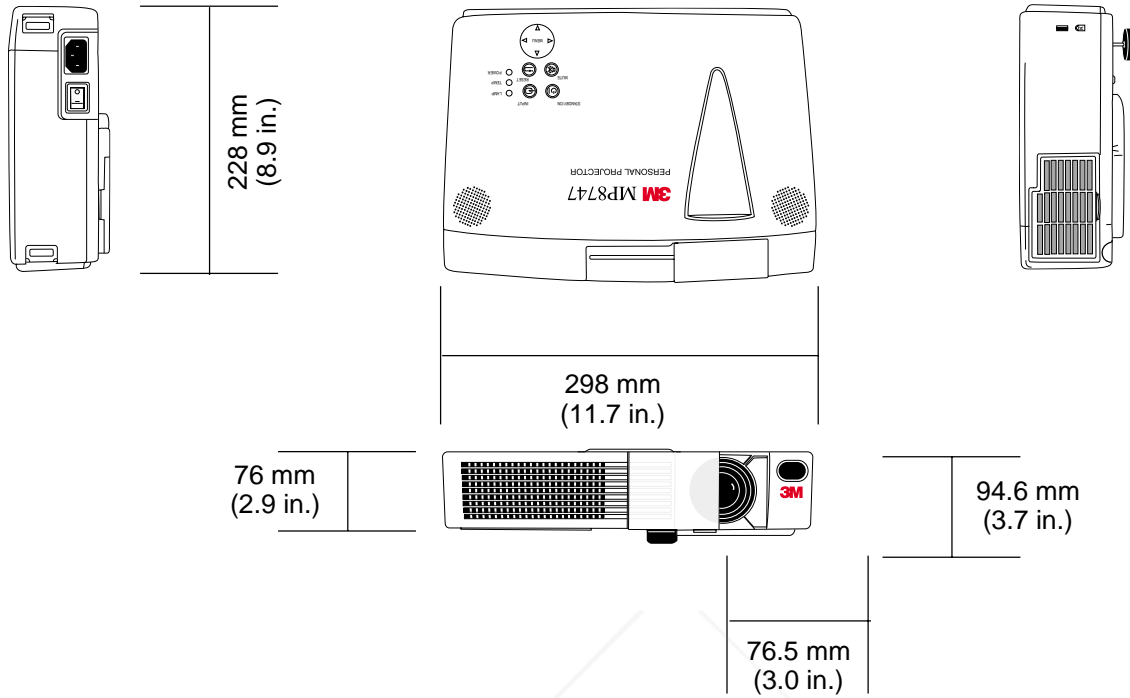

RGB Signal Pin Assign

Pin No.	Signal	Pin No.	Signal
1	Video input Red	11	-
2	Video input Green	12	RGB IN 1: SDA (DDC)
3	Video input Blue		RGB IN 2: -
4	-		RGB OUT: -
5	Ground	13	H. sync. / Composite sync.
6	Ground Red		
7	Ground Green	14	Vertical sync.
8	Ground Blue	15	RGB IN 1: (SCL (DDC)
9	-		RGB IN 2: -
10	Ground		RGB OUT: -

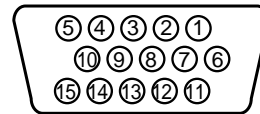

S-Video Signal Pin Assign

Pin No.	Signal
1	Color: 0.286Vp-p (burst signal), 75 Ω terminator
2	Brightness: 1.0Vp-p, 75 Ω terminator
3	Ground
4	Ground



mini DIN 4-pin

Example of Computer Signal

Resolution H x V	fH (kHz)	fV (Hz)	Rating	Signal Mode	Display Mode
640 x 350	37.9	85.1	VESA	VGA-1	Zoom in
640 x 400	37.9	85.1	VESA	VGA-2	Zoom in
720 X 400	37.9	85.0	VESA	TEXT	Zoom in
640 X 480	31.5	59.9	VESA	VGA-3	Zoom in
640 X 480	35.0	66.7		Mac13"mode	Zoom in
640 x 480	37.9	72.8	VESA	VGA-3(72Hz)	Zoom in
640 x 480	37.5	75.0	VESA	VGA-3(75Hz)	Zoom in
640 x 480	43.3	85.0	VESA	VGA-3(85Hz)	Zoom in
800 x 600	35.2	56.3	VESA	SVGA(56Hz)	Zoom in
800 x 600	37.9	60.3	VESA	SVGA(60Hz)	Zoom in
800 x 600	48.1	72.2	VESA	SVGA(72Hz)	Zoom in
800 x 600	46.9	75.0	VESA	SVGA(75Hz)	Zoom in
800 x 600	53.7	85.1	VESA	SVGA(85Hz)	Zoom in
832 x 624	49.7	74.5		Mac16"mode	Zoom in
1024 x 768	48.4	60.0	VESA	XGA(60Hz)	
1024 x 768	56.5	70.1	VESA	XGA(70Hz)	
1024 x 768	60.0	75.0	VESA	XGA(75Hz)	
1024 x 768	68.7	85.0	VESA	SXGA(85Hz)	
1152 x 864	67.5	75.0	VESA	SXGA(75Hz)	Zoom out
1280 x 960	60.0	60.0	VESA	SXGA(60Hz)	Zoom out
1280 x 1024	64.0	60.0	VESA	SXGA(75Hz)	Zoom out
1280 x 1024	80.0	75.0	VESA	SXGA(75Hz)	Zoom out

✓ **Note:** • Some computers may have multiple display screen modes. Use of some of these modes will not be possible with this projector.

• Be sure to check jack type, signal level, timing and resolution before connecting this projector to a computer.

• Depending on the input signal, full-size display may not be possible in some cases. Refer to the number of display pixels above.

Initial Set Signals

The following signals are used for the initial settings.

The signal timing of some computer models may be different. In such case, refer to adjust the V.POSIT and H.POSIT of the menu.

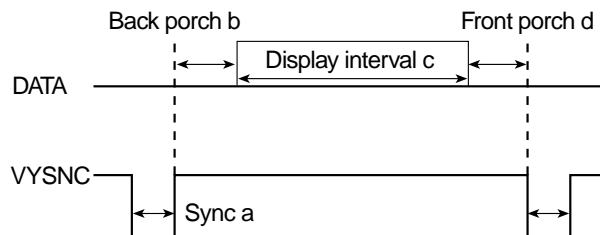
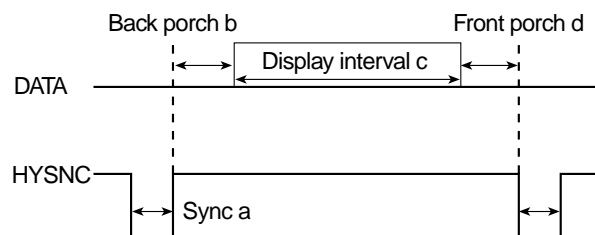

Computer/Signal	Horizontal signal timing (μs)			
	a	b	c	d
VGA-1(85Hz)	2.0	3.0	20.3	1.0
VGA-2(85Hz)	2.0	3.0	20.3	1.0
TEXT	2.0	3.0	20.3	1.0
VGA-3	3.8	1.9	25.4	0.6
Mac 13" mode	2.1	3.2	21.2	2.1
VGA-3(72Hz)	1.3	3.8	20.3	1.0
VGA-3(75Hz)	2.0	3.8	20.3	0.5
VGA-3(85Hz)	1.6	2.2	17.8	1.6
SVGA(56Hz)	2.0	3.6	22.2	0.7
SVGA(60Hz)	3.2	2.2	20.0	1.0
SVGA(72Hz)	2.4	1.3	16.0	1.1
SVGA(75Hz)	1.6	3.2	16.2	0.3
SVGA(85Hz)	1.1	2.7	14.2	0.6
Mac 16" mode	1.1	3.9	14.5	0.6
XGA (60Hz)	2.1	2.5	15.8	0.4
XGA (70Hz)	1.8	1.9	13.7	0.3
XGA (75Hz)	1.2	2.2	13.0	0.2
XGA (85Hz)	1.0	2.2	10.8	0.5
1152 x 864 (75Hz)	1.2	2.4	10.7	0.6
1280 x 960 (60Hz)	1.0	2.9	11.9	0.9
1280 x 1024 (60Hz)	1.0	2.3	11.9	0.4
1280 x 1024 (75Hz)	1.1	1.8	9.5	0.1

Computer/Signal	Vertical signal timing (μs)			
	a	b	c	d
VGA-1(85Hz)	3	60	350	32
VGA-2(85Hz)	3	41	400	1
TEXT	3	42	480	1
VGA-3	2	33	480	10
Mac 13" mode	3	39	480	3
VGA-3(72Hz)	3	28	480	9
VGA-3(75Hz)	3	16	480	1
VGA-3(85Hz)	3	25	480	1
SVGA(56Hz)	2	22	600	1
SVGA(60Hz)	4	23	600	1
SVGA(72Hz)	6	23	600	37
SVGA(75Hz)	3	21	600	1
SVGA(85Hz)	3	27	600	1
Mac 16" mode	3	39	624	1
XGA (60Hz)	6	29	768	3
XGA (70Hz)	6	29	768	3
XGA (75Hz)	3	28	768	1
XGA (85Hz)	3	36	768	1
1152 x 864 (75Hz)	3	32	864	1
1280 x 960 (60Hz)	3	36	960	1
1280 x 1024 (60Hz)	3	38	1024	1
1280 x 1024 (75Hz)	3	38	1024	1

Connection to the Mouse Control

PS/2, ADB or Serial Mouse

1. Turn off the projector and computer, and connect the two units with the appropriate cable. For PS/2 mouse control (for IBM and compatible), use the enclosed mouse cable. For others, consult your dealer.
2. Disconnect the USB cable from the projector if it is connected. Then turn on the projector.
3. Turn on the computer.
4. Start the mouse function. If the mouse has not been started, reboot the computer (soft reboot or reboot buttons). Refer to the descriptions of “DISC PAD” and “MOUSE/RIGHT BUTTON” on page 12.

USB Mouse

1. Connect the projector and computer with a suitable commercially available USB cable. Consult your dealer to get the cable, if needed.
2. Start the mouse function. Refer to the descriptions of “DISC PAD” and “MOUSE/RIGHT BUTTON” on page 12.

- ✓ **Note:**
- *Before connecting, read the instruction manuals of the devices to be connected.*
 - *In the case of laptop computers with an internal pointing device, the mouse control will not work. In this situation, disable the internal pointing device and change the BIOS setting to select an external mouse before the operations described in the steps above.*
 - *Some computers may not have utility program to operate a mouse.*
 - *Refer to the computer hardware manual for details.*

PS/2 Mouse

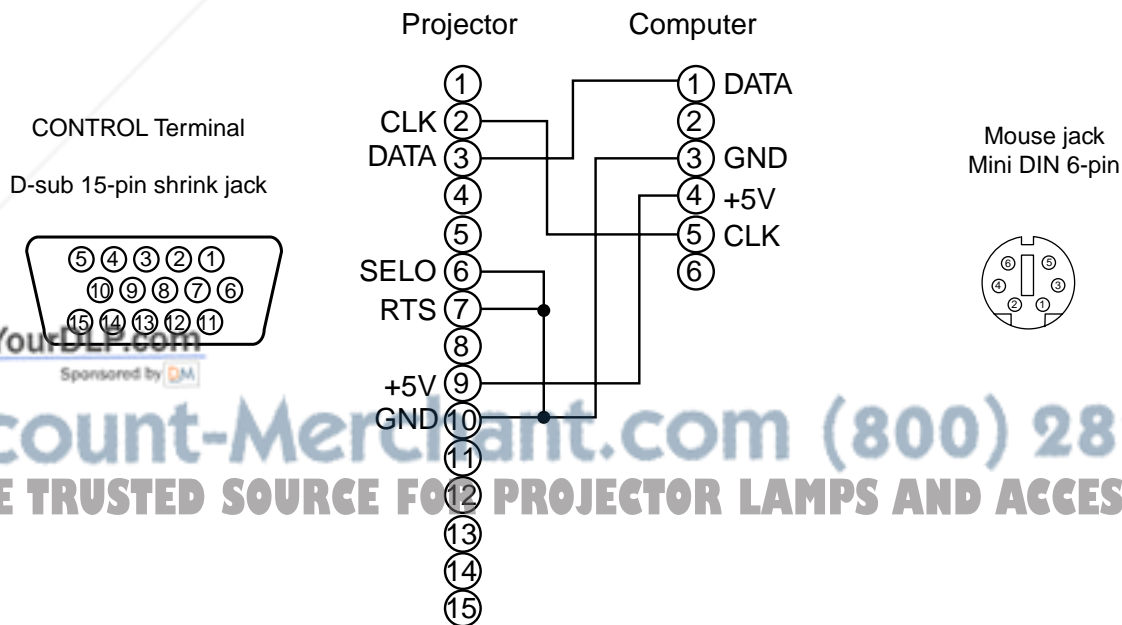

Connection to the Mouse Control (continued)

ADB Mouse

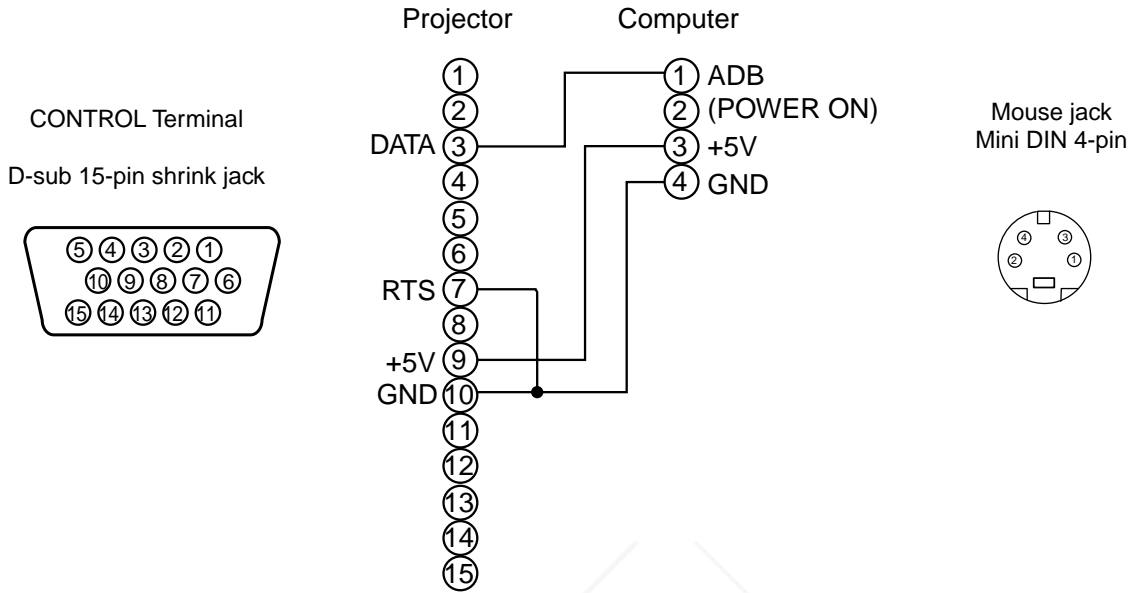

Serial Mouse

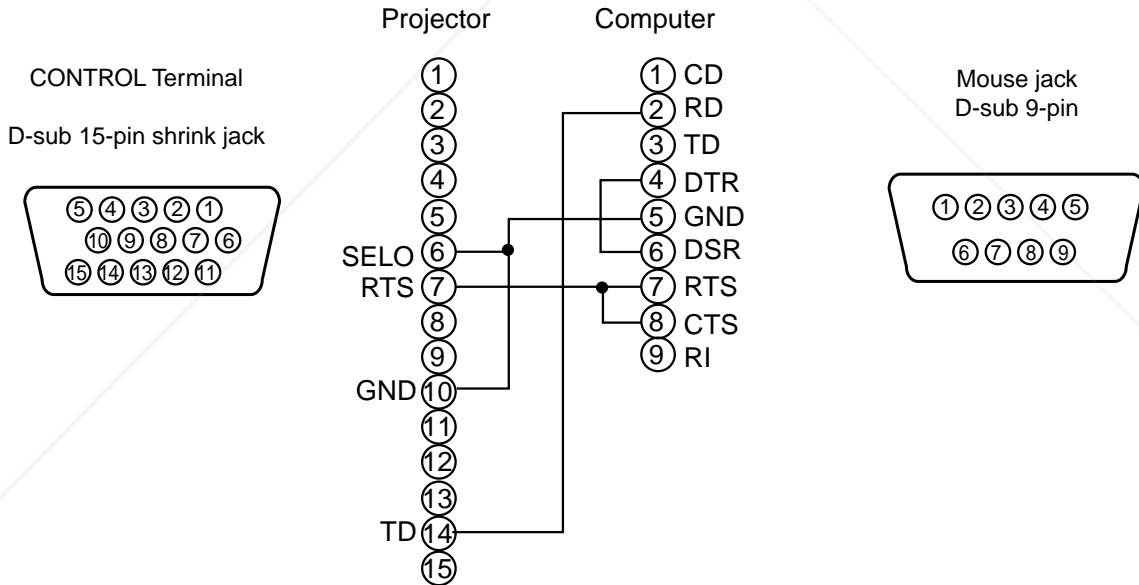

Sponsored by DM
USB jack
(B type)

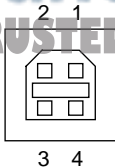

USB jack
(A type)

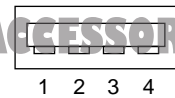

USB Cable

RS-232 Communication

1. Turn off the projector and computer power supplies and connect with the RS-232C cable.
2. Turn on the computer power supply and, after the computer has started up, turn on the projector power supply.

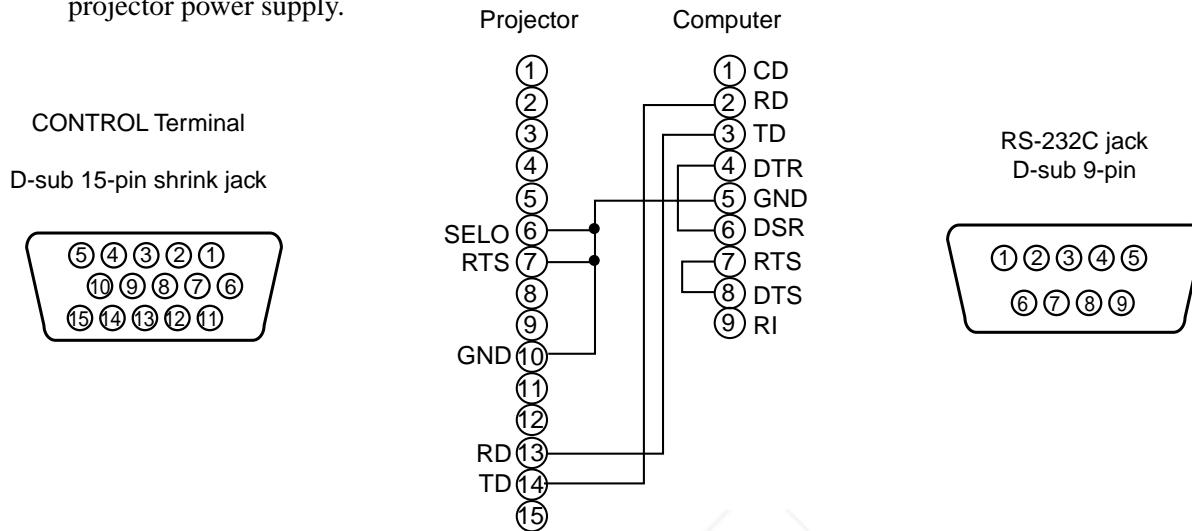

Communications Setting

19200bps, 8N1

1 Protocol

Consist of header (7 bytes) + command data (6 bytes).

2 Header

BE + EF + 03 + 06 + 00 + CRC_low + CRC_high

CRC_low: Lower byte of CRC flag for command data.

CRC_high: Upper byte of CRC flag for command data.

3 Command data

byte_0	byte_1	byte_2	byte_3	byte_4	byte_5
Action		Type		Setting Code	
low	high	low	high	low	high

Action	Classification	Content
1	SET	Change setting to desired value.
2	GET	Read projector internal setup value.
4	INCREMENT	Increment setup value by 1
5	DECREMENT	Decrement setup value by 1
6	EXECUTE	Run a command.

Requesting projector status (Get command)

1. Send the request code Header + Command data ('02H' + '00H' + type (2 bytes) + '00H' + '00H) from the computer to the projector.
2. The projector returns the response code '1DH' + data (2 bytes) to the computer.

Changing the projector settings (Set command)

1. Send the setting code Header + Command data ('01H' + '00H' + type (2 bytes) + setting code (2 bytes)) from the computer to the projector.
2. The projector changes the setting based on the above setting code.
3. The projector returns the response code '06H' to the computer.

Using the projector default settings (Reset command)

1. The computer sends the default setting code Header + Command + data ('06H' + '00H' + type (2 bytes) + '00H' + '00H') to the projector.
2. The projector changes the specified setting to the default value.
3. The projector returns the response code '06H' to the computer.

Increasing the projector setting value (Increment command)

1. The computer sends the increment code Header + Command data ('04H' + '00H' + type (2 bytes) + '00H' + '00H') to the projector.
2. The projector increases the setting value on the above setting code.
3. The projector returns the response code '06H' to the computer.

Decreasing the projector setting value (Decrement command)

1. The computer sends the decrement code Header + Command data ('05H' + '00H' + type (2 bytes) + '00H' + '00H') to the projector.
2. The projector decreases the setting value on the above setting code.
3. The projector returns the response code '06H' to the computer.

When a command sent by the projector cannot be understood by the computer

When the command sent by the projector cannot be understood, the error command '15H' is returned by the computer. Sometimes, the projector ignores RS-232C commands during other tasks. If the error command '15H' is returned, please send the same command again.

When data sent by the projector cannot be practiced

When the command sent by the projector cannot be practiced, then the error code '1cH' + 'xxxxH' is returned.

When the data length is greater than indicated by the data length code, the projector will ignore the excess data code.

Conversely, when the data length is shorter than indicated by the data length code, an error code will be returned to the projector.

Note: • Operation cannot be guaranteed when the projector receives an undefined command or data.

- Provide an interval of at least 40µs between the response code and any other code.
- The projector outputs test data when the power supply is switched ON, and when the lamp is lit. Ignore this data.
- Commands are not accepted during warm-up.

Technical Appendix

Names	Operation Type		Header	Command Data			
				CRC	Action	Type	Setting code
Blank Color	Set	Red	BE EF 03 06 00	3B D3	01 00	00 30	00 00
		Orange	BE EF 03 06 00	AB D2	01 00	00 30	01 00
		Green	BE EF 03 06 00	5B D2	01 00	00 30	02 00
		Blue	BE EF 03 06 00	CB D3	01 00	00 30	03 00
		Purple	BE EF 03 06 00	FB D1	01 00	00 30	04 00
		White	BE EF 03 06 00	6B D0	01 00	00 30	05 00
		Black	BE EF 03 06 00	9B D0	01 00	00 30	06 00
	Get	BE EF 03 06 00	08 D3	02 00	00 30	00 00	
Mirror	Set	Normal	BE EF 03 06 00	C7 D2	01 00	01 30	00 00
		H Inverse	BE EF 03 06 00	57 D3	01 00	01 30	01 00
		V Inverse	BE EF 03 06 00	A7 D3	01 00	01 30	02 00
		H & V Inverse	BE EF 03 06 00	37 D2	01 00	01 30	03 00
	Get	BE EF 03 06 00	F4 D2	02 00	01 30	00 00	
Freeze	Set	Normal	BE EF 03 06 00	83 D2	01 00	02 30	00 00
		Freeze	BE EF 03 06 00	13 D3	01 00	02 30	01 00
	Get	BE EF 03 06 00	B0 D2	02 00	02 30	00 00	
Menu Color	Set	Red	BE EF 03 06 00	46 D3	01 00	02 20	00 00
		Orange	BE EF 03 06 00	EF D2	01 00	03 30	01 00
		Green	BE EF 03 06 00	1F D2	01 00	03 30	02 00
		BLUE	BE EF 03 06 00	8F D3	01 00	03 30	03 00
		Purple	BE EF 03 06 00	BF D1	01 00	03 30	04 00
		Transparent	BE EF 03 06 00	2F D0	01 00	03 30	05 00
		Gray	BE EF 03 06 00	4C D3	02 00	03 30	00 00
	Get	BE EF 03 06 00	75 D3	02 00	02 20	00 00	
Startup	Set	Turn ON	BE EF 03 06 00	0B D2	01 00	04 30	00 00
		Turn OFF	BE EF 03 06 00	9B D3	01 00	04 30	01 00
	Get	BE EF 03 06 00	38 D2	02 00	04 30	00 00	
Language	Set	English	BE EF 03 06 00	F7 D3	01 00	05 30	00 00
		Français	BE EF 03 06 00	9B D3	01 00	05 30	01 00
		Deutsch	BE EF 03 06 00	97 D2	01 00	05 30	02 00
		Español	BE EF 03 06 00	07 D3	01 00	05 30	03 00
		Italiano	BE EF 03 06 00	37 D1	01 00	05 30	04 00
		Norsk	BE EF 03 06 00	A7 D0	01 00	05 30	05 00
		Nederlands	BE EF 03 06 00	57 D0	01 00	05 30	06 00
		Portugues	BE EF 03 06 00	C7 D1	01 00	05 30	07 00
		Japanese	BE EF 03 06 00	37 D4	01 00	05 30	08 00
	Get	BE EF 03 06 00	C4 D3	02 00	05 30	00 00	

Technical Appendix

Names	Operation Type		Header	Command Data			
				CRC	Action	Type	Setting code
Magnify	Get		BE EF 03 06 00	7C D2	02 00	07 30	00 00
	Increment		BE EF 03 06 00	1A D2	04 00	07 30	00 00
	Decrement		BE EF 03 06 00	CB D3	05 00	07 30	00 00
Timer	Get		BE EF 03 06 00	C8 82	02 00	00 31	00 00
	Increment		BE EF 03 06 00	AE 82	04 00	00 31	00 00
	Decrement		BE EF 03 06 00	7F 83	05 00	00 31	00 00
Auto off	Get		BE EF 03 06 00	C8 72	02 00	00 32	00 00
	Increment		BE EF 03 06 00	AE 72	04 00	00 32	00 00
	Decrement		BE EF 03 06 00	7F 73	05 00	00 32	00 00
Brightness Reset	Execute		BE EF 03 06 00	58 D3	06 00	00 70	00 00
Contrast Reset	Execute		BE EF 03 06 00	A4 D2	06 00	01 70	00 00
V.Position Reset	Execute		BE EF 03 06 00	E0 D2	06 00	02 70	00 00
H.Position Reset	Execute		BE EF 03 06 00	IC D3	06 00	03 70	00 00
H.Size Reset	Execute		BE EF 03 06 00	68 D2	06 00	04 70	00 00
Color Balance R Reset	Execute		BE EF 03 06 00	94 D3	06 00	05 70	00 00
Color Balance B Reset	Execute		BE EF 03 06 00	D0 03	06 00	06 70	00 00
Aspect Reset	Execute		BE EF 03 06 00	2C D2	06 00	07 70	00 00
Video Format Reset	Execute		BE EF 03 06 00	38 D1	06 00	08 70	00 00
Sharpness Reset	Execute		BE EF 03 06 00	C4 D0	06 00	09 70	00 00
Color Reset	Execute		BE EF 03 06 00	80 D0	06 00	0A 70	00 00
Tint Reset	Execute		BE EF 03 06 00	7C D1	06 00	0B 70	00 00
Keystone Reset	Execute		BE EF 03 06 00	08 D0	06 00	0C 70	00 00
Mirror Reset	Execute		BE EF 03 06 00	F4 D1	06 00	0D 70	00 00
Blank Color Reset	Execute		BE EF 03 06 00	B0 D1	06 00	0E 70	00 00
Startup Reset	Execute		BE EF 03 06 00	4C D0	06 00	0F 70	00 00
Auto	Execute		BE EF 03 06 00	91 D0	06 00	0A 20	00 00
Blank on/off	Set	off	BE EF 03 06 00	FB D8	01 00	20 30	00 00
		on	BE EF 03 06 00	6B D9	01 00	20 30	00 00
	Get		BE EF 03 06 00	C8 D8	02 00	20 30	00 00
Timer on/off	Set	off	BE EF 03 06 00	07 D9	01 00	21 30	00 00
		on	BE EF 03 06 00	97 D8	01 00	21 30	00 00
	Get		BE EF 03 06 00	34 D9	01 00	21 30	00 00
Error Status	Set	off	BE EF 03 06 00	D9 D8	02 00	20 60	00 00
		on	00 00 01 00 02 00 03 00 (Normal) (Cover-error) (Fan-error) (Lamp-error)				
	Get		04 00 05 00 06 00 (Temp-error) (Air flow-error) (Lamp-Time-over)				

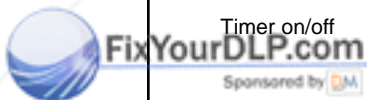

Discount-Merchant.com (800) 281-8860
 THE TRUSTED SOURCE FOR PROJECTOR LAMPS AND ACCESSORIES

Technical Appendix

Names	Operation Type		Header	Command Data			
				CRC	Action	Type	Setting code
Power	Set	OFF	BE EF 03 06 00	2A D3	01 00	00 60	00 00
		ON	BE EF 03 06 00	BA D2	04 00	00 60	01 00
	Get		BE EF 03 06 00	19 D3	05 00	00 60	00 00
Input Source	Set	RGB1	BE EF 03 06 00	FE D2	02 00	00 20	00 00
		RGB2	BE EF 03 06 00	3E D0	01 00	00 20	04 00
		Video	BE EF 03 06 00	6E D3	04 00	00 20	01 00
		SVideo	BE EF 03 06 00	9E D3	05 00	00 20	02 00
	Get		BE EF 03 06 00	CD D2	02 00	00 20	00 00
Volume	Get		BE EF 03 06 00	31 D3	02 00	01 20	00 00
	Increment		BE EF 03 06 00	57 D3	04 00	01 20	00 00
	Decrement		BE EF 03 06 00	86 D2	05 00	01 20	00 00
Mute	Set	Normal	BE EF 03 06 00	46 D3	01 00	02 20	00 00
		Mute	BE EF 03 06 00	D6 D2	01 00	02 20	01 00
	Get		BE EF 03 06 00	75 D3	02 00	02 20	00 00
Brightness	Get		BE EF 03 06 00	89 D2	02 00	03 20	00 00
	Increment		BE EF 03 06 00	EF D2	04 00	03 20	00 00
	Decrement		BE EF 03 06 00	3E D3	05 00	03 20	00 00
Contrast	Get		BE EF 03 06 00	FD D3	02 00	04 20	00 00
	Increment		BE EF 03 06 00	9B D3	04 00	04 20	00 00
	Decrement		BE EF 03 06 00	4A D2	05 00	04 20	00 00
Color Balance R	Get		BE EF 03 06 00	01 D2	02 00	05 20	00 00
	Increment		BE EF 03 06 00	67 D2	04 00	05 20	00 00
	Decrement		BE EF 03 06 00	B6 D3	05 00	05 20	00 00
Color Balance B	Get		BE EF 03 06 00	45 D2	02 00	06 20	00 00
	Increment		BE EF 03 06 00	23 D2	04 00	06 20	00 00
	Decrement		BE EF 03 06 00	F2 D3	05 00	06 20	00 00
Keystone	Get		BE EF 03 06 00	B9 D3	02 00	07 20	00 00
	Increment		BE EF 03 06 00	DF D3	04 00	07 20	00 00
	Decrement		BE EF 03 06 00	0E D2	05 00	07 20	00 00
Aspect	Set	4:3	BE EF 03 06 00	9E D0	01 00	08 20	00 00
		16:9	BE EF 03 06 00	0E D1	01 00	08 20	01 00
		Small	BE EF 03 06 00	FE D1	01 00	08 20	02 00
	Get		BE EF 03 06 00	AD D0	02 00	08 20	00 00
Display Position at 16:9 or Small	Set	Default	BE EF 03 06 00	62 D1	01 00	09 20	00 00
		Bottom	BE EF 03 06 00	F2 D0	01 00	09 20	01 00
		Top	BE EF 03 06 00	02 D0	01 00	09 20	02 00
	Get		BE EF 03 06 00	51 D1	02 00	09 20	00 00

Technical Appendix

Names	Operation Type	Header	Command Data				
			CRC	Action	Type	Setting code	
V. Position	Get	BE EF 03 06 00	0D 83	02 00	00 21	00 00	
	Increment	BE EF 03 06 00	6B 83	04 00	00 21	00 00	
	Decrement	BE EF 03 06 00	BA 82	05 00	00 21	00 00	
H. Position	Get	BE EF 03 06 00	F1 82	02 00	01 21	00 00	
	Increment	BE EF 03 06 00	97 82	04 00	01 21	00 00	
	Decrement	BE EF 03 06 00	46 83	05 00	01 21	00 00	
H. Size	Get	BE EF 03 06 00	B5 82	02 00	02 21	00 00	
	Increment	BE EF 03 06 00	D3 82	04 00	02 21	00 00	
	Decrement	BE EF 03 06 00	02 83	05 00	02 21	00 00	
H. Phase	Set	Normal	BE EF 03 06 00	49 83	02 00	03 21	00 00
		Mute	BE EF 03 06 00	2F 83	04 00	03 21	00 00
	Get	BE EF 03 06 00	FE 82	05 00	03 21	00 00	
Sharpness	Get	BE EF 03 06 00	F1 72	02 00	01 22	00 00	
	Increment	BE EF 03 06 00	97 72	04 00	01 22	00 00	
	Decrement	BE EF 03 06 00	46 73	05 00	01 22	00 00	
Color	Get	BE EF 03 06 00	B5 72	02 00	02 22	00 00	
	Increment	BE EF 03 06 00	D3 72	04 00	02 22	00 00	
	Decrement	BE EF 03 06 00	02 73	05 00	02 22	00 00	
Tint	Get	BE EF 03 06 00	49 73	02 00	03 22	00 00	
	Increment	BE EF 03 06 00	2F 73	04 00	03 22	00 00	
	Decrement	BE EF 03 06 00	FE 72	05 00	03 22	00 00	
Video Format	Set	Auto	BE EF 03 06 00	9E 75	01 00	00 22	0A 00
		NTSC	BE EF 03 06 00	FE 71	01 00	00 22	04 00
		PAL	BE EF 03 06 00	6E 70	01 00	00 22	05 00
		SECAM	BE EF 03 06 00	6E 75	01 00	00 22	09 00
		NTSC 4.43	BE EF 03 06 00	5E 72	01 00	00 22	02 00
		M-PAL	BE EF 03 06 00	FE 74	01 00	00 22	08 00
		N-PAL	BE EF 03 06 00	0E 71	01 00	00 22	07 00
	Get	BE EF 03 06 00	0D 73	02 00	00 22	00 00	

(This page intentionally left blank for printed version.)



Discount-Merchant.com (800) 281-8860
THE TRUSTED SOURCE FOR PROJECTOR LAMPS AND ACCESSORIES

Important Notice

All statements, technical information, and recommendations related to 3M's products are based on information believed to be reliable, but the accuracy or completeness is not guaranteed. Before using this product, you must evaluate it and determine if it is suitable for your intended application. You assume all risks and liability associated with such use. Any statements related to the product which are not contained in 3M's current publications, or any contrary statements contained on your purchase order shall have no force or effect unless expressly set forth in a written agreement signed by an authorized officer of 3M.

Warranty and Limited Remedy. This product will be free from defects in material and manufacture for a period of two years from the date of purchase. Exclusion to Warranty: The lamps are considered a consumable item and are warranted for 90 days or 180 hours, whichever occurs first. **3M MAKES NO OTHER WARRANTIES, INCLUDING BUT NOT LIMITED TO, ANY IMPLIED WARRANTY OF MERCHANTABILITY OR FITNESS FOR A PARTICULAR PURPOSE.** If this product is defective within the warranty period stated above, your exclusive remedy shall be, at 3M's option, to replace or repair the 3M product or refund the purchase price of the 3M product.

Limitation of Liability. Except where prohibited by law, 3M will not be liable for any loss or damage arising from this 3M product, whether direct, indirect, special, incidental or consequential regardless of the legal theory asserted.

Let us help you make the most of your next presentation. We offer everything from presentation supplies to tips for better meetings. And we're the only transparency manufacturer that offers a recycling program for your used transparencies. For late-breaking news, handy reference and free product samples, call us toll-free in the continental United States and Canada, 24 hours a day, or visit our Internet Website.



<http://www.3m.com/meetings>
 e-mail: meetings@mmm.com
800-328-1371
 FixYourDLF.com
 Sponsored by
Discount-Merchant.com (800) 281-8860
THE TRUSTED SOURCE FOR PROJECTOR LAMPS AND ACCESSORIES

3M Austin Center
Building A145-5N-01
6801 River Place Blvd.
Austin, TX 78726-9000

3M Canada
P.O. Box 5757
London, Ontario
N6A 4T1

3M Mexico, S.A. de C.V.
Apartado Postal 14-139
Mexico, D.F. 07000
Mexico

3M Europe
Boulevard de l'Oise
95006 Cerge Pontoise Cedex
France

Litho in Japan
Copyright © 2000 3M IPC.
All Rights Reserved
78-6970-9050-0 Rev. A



Discount-Merchant.com (800) 281-8860
THE TRUSTED SOURCE FOR PROJECTOR LAMPS AND ACCESSORIES



Disclaimer

This user manual is provided as a free service by FixYourDLP.com. FixYourDLP is in no way responsible for the content of this manual, nor do we guarantee its accuracy. FixYourDLP does not make any claim of copyright and all copyrights remain the property of their respective owners.

About FixYourDLP.com

FixYourDLP.com (<http://www.fixyourdlp.com>) is the World's #1 resource for media product news, reviews, do-it-yourself guides, and manuals.

Informational Blog: <http://www.fixyourdlp.com>

Video Guides: <http://www.fixyourdlp.com/guides>

User Forums: <http://www.fixyourdlp.com/forum>

FixYourDLP's Fight Against Counterfeit Lamps:

<http://www.fixyourdlp.com/counterfeits>

Sponsors:

RecycleYourLamp.org – Free lamp recycling services for used lamps:

<http://www.recycleyourlamp.org>

Lamp Research - The trusted 3rd party lamp research company:

<http://www.lampresearch.com>

Discount-Merchant.com – The worlds largest lamp distributor:

<http://www.discount-merchant.com>



FixYourDLP.com

Sponsored by 