



Disclaimer

This user manual is provided as a free service by FixYourDLP.com. FixYourDLP is in no way responsible for the content of this manual, nor do we guarantee its accuracy. FixYourDLP does not make any claim of copyright and all copyrights remain the property of their respective owners.

About FixYourDLP.com

FixYourDLP.com (<http://www.fixyourdlp.com>) is the World's #1 resource for media product news, reviews, do-it-yourself guides, and manuals.

Informational Blog: <http://www.fixyourdlp.com>

Video Guides: <http://www.fixyourdlp.com/guides>

User Forums: <http://www.fixyourdlp.com/forum>

FixYourDLP's Fight Against Counterfeit Lamps:

<http://www.fixyourdlp.com/counterfeits>

Sponsors:

RecycleYourLamp.org – Free lamp recycling services for used lamps:

<http://www.recycleyourlamp.org>

Lamp Research - The trusted 3rd party lamp research company:

<http://www.lampresearch.com>

Discount-Merchant.com – The worlds largest lamp distributor:

<http://www.discount-merchant.com>



FixYourDLP.com

Sponsored by 

3M

MP7720 Personal Projector

User's Guide

English

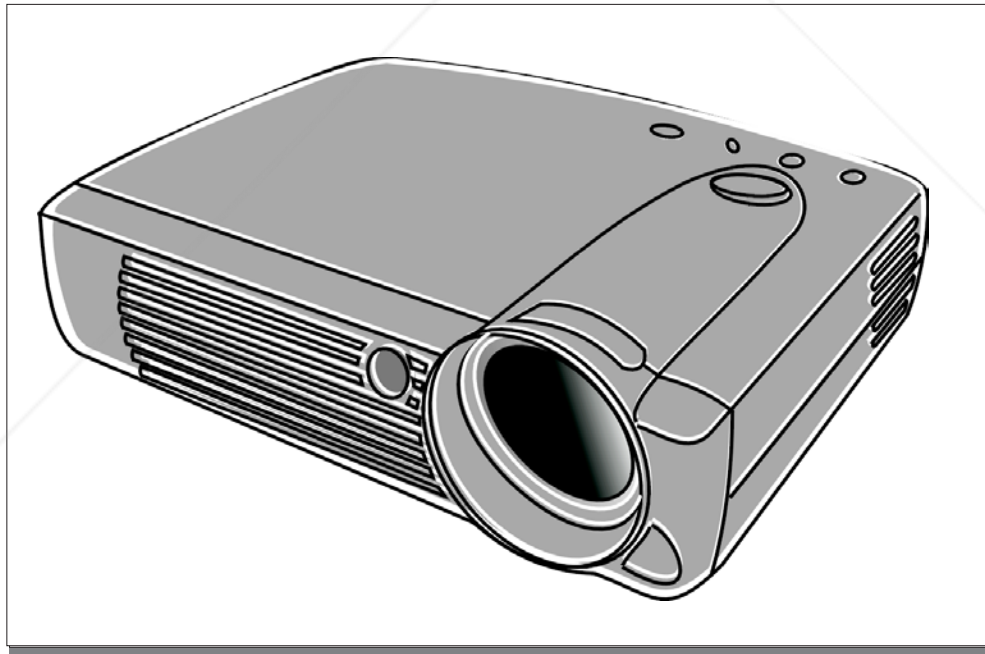

 FixYourDLP.com
Sponsored by 

Discount-Merchant.com (800) 281-8860

THE TRUSTED SOURCE FOR PROJECTOR LAMPS AND ACCESSORIES



Discount-Merchant.com (800) 281-8860
THE TRUSTED SOURCE FOR PROJECTOR LAMPS AND ACCESSORIES

Table of Contents

INTRODUCTION	1
Safety Instructions	-1
Warranty	-2
Limited Warranty	2
Shipping Contents	-3
Optional Accessories	-4
Projector Description	-4
Projector	4
External Control Panel	5
Projector Features	6
Remote Control Description	-7
Remote Control Features	7
Installing or Replacing Batteries	9
INSTALLATION	10
Screen Size	-10
Connecting to Various Equipment	-10
OPERATION	11
Start Up	-11
Digital Keystone Correction	-12
Auto Adjustment	-12
Source Selection	-13
Menu System	-13
1. Display Menu	14
2. Image Menu	15
3. Image Sub-menu with AV Input	17
4. Control Menu	17
5. Source Menu	20
Shutdown	-21
MAINTENANCE	22
Lamp Information	-22
Use and Replacement of Lamp	22
Status LED Indicators	22
Lamp Replacement	-23
Resetting Lamp Hours	-24
Service information	-25
Accessories (Included in standard packet)	25
Description of Part Number (Not Included in Standard Packet)	25
Ordering Parts or Getting Information	25
TROUBLESHOOTING	26
Common Problems & Solutions	-26
Status Messages	-27
SPECIFICATIONS	28
Projector specifications	28
Timing chart	-29
DIMENSIONS	30



FixYourDL.com
Sponsored by

DiscountMerchant.com (800) 281-8860
THE TRUSTED SOURCE FOR PROJECTOR LAMPS AND ACCESSORIES

Introduction

 **Caution**

TO PREVENT SHOCK, DO NOT OPEN THE CABINET. NO USER –SERVICEABLE PARTS INSIDE. REFER SERVICING TO QUALIFIED SERVICE PERSONNEL. AND PLEASE READ ALL OF THESE INSTRUCTIONS BEFORE YOU OPERATE YOUR PROJECTOR. KEEP THESE INSTRUCTIONS FOR FUTURE REFERENCE .

Safety Instructions

1. Read all of these instructions before you operate your projector and save them for future reference.
2. The lamp becomes extremely hot during operation. Keep the projector cool for approximately 45 minutes prior to removing the lamp assembly for replacement. Do not operate lamps beyond the rated lamp life. Excessive operation of lamps beyond rated life could cause them to explode in rare occasions.
3. Power is still available when the projector is in the standby mode. Never replace lamp assembly or any electronic components unless the projector is unplugged.
4. To reduce the risk of electric shock, do not disassemble this appliance. Take it to a qualified technician when service or repair work is required. Incorrect reassembly can cause electric shock when the appliance is subsequently used.
5. Do not place this product on an unstable cart, stand, or table. The product may fall, causing serious damage to the product.
6. This product is capable of displaying inverted images for ceiling mount configurations. Please use suitable equipment for mounting the unit and make sure it is securely installed.
7. To prevent the lamp from bursting, change the lamp after changing the mounting position of the projector (desktop to ceiling mount or ceiling mount to desktop mount).

 **Caution**

- **Always open the lens shutter or remove the lens cap when the projector lamp is on.**
- **Do not look straight at the projector lens during operation. The intense light beam may damage your eyesight.**
- **In some countries, the line voltage is NOT stable. This projector is designed to operate safely within a bandwidth of 110 to 230 volts, but could fail if power drops or surges of ± 10 volts occur. In these high-risk areas, it is recommended to install a power stabilizer unit.**

Save These Instructions: The information contained in this manual will help you operate and maintain your 3M™ MP7720 Personal Projector.

Warranty

Limited Warranty

3M warrants this product against any defects in material and workmanship, under normal usage and storage, for a period of two years from date of purchase.

Exclusion to Warranty: The lamps are considered a consumable item and are warranted for 90 days or 180 hours, whichever occurs first. Proof of purchase date will be required with any warranty claim. In the event this product is found to be defective within the warranty period, 3M's only obligation and your exclusive remedy shall be replacement of any defective parts (labor included). To obtain warranty service, immediately notify the dealer from which you purchased the product of any defects.

Important: The above warranty shall be void if the customer fails to operate the product in accordance with 3M's written instructions. This warranty gives you specific legal rights, and you may have other rights which vary from state to state.

FCC STATEMENT - CLASS A: This equipment generates, uses and can radiate radio frequency energy, and if not installed and used in accordance with the instruction manual, may cause interference to radio communications. It has been tested and found to comply with the limits for a Class "A" computing device pursuant to Subpart B of Part 15 of the FCC Rules, which are designed to provide reasonable protection against such interference when operated in a commercial environment. Operation of this equipment in a residential area is likely to cause interference, in which case the user at his/her own expense will be required to take whatever measures may be required to correct the interference.

FCC STATEMENT - CLASS B: This equipment generates, uses and can radiate radio frequency energy and, if not installed and used in accordance with the instructions, may cause harmful interference to radio communications. However, there is no guarantee that interference will not occur in a particular installation. If this equipment does cause harmful interference to radio or television reception, which can be determined by turning the equipment off and on, the user is encouraged to try to correct the interference by one or more of the following measures:

- Reorient or relocate the receiving antenna.
- Increase the distance between the equipment and receiver.
- Connect the equipment into an outlet on a circuit different from that to which the receiver is connected.
- Consult the dealer or an experienced radio/TV technician for help.

EEC STATEMENT: This machine was tested against the 89/336/EEC (European Economic Community) for EMC (Electro Magnetic Compatibility) and fulfills these requirements.



Discount-Merchant.com (800) 281-8860
THE TRUSTED SOURCE FOR PROJECTOR LAMPS AND ACCESSORIES

Shipping Contents

The 3M™ MP7720 Projector is shipped with the necessary cables required for standard PC, Macintosh or laptop computer connections. Carefully unpack and verify that you have all of the items shown below. If any of these items are missing, please contact your place of purchase.

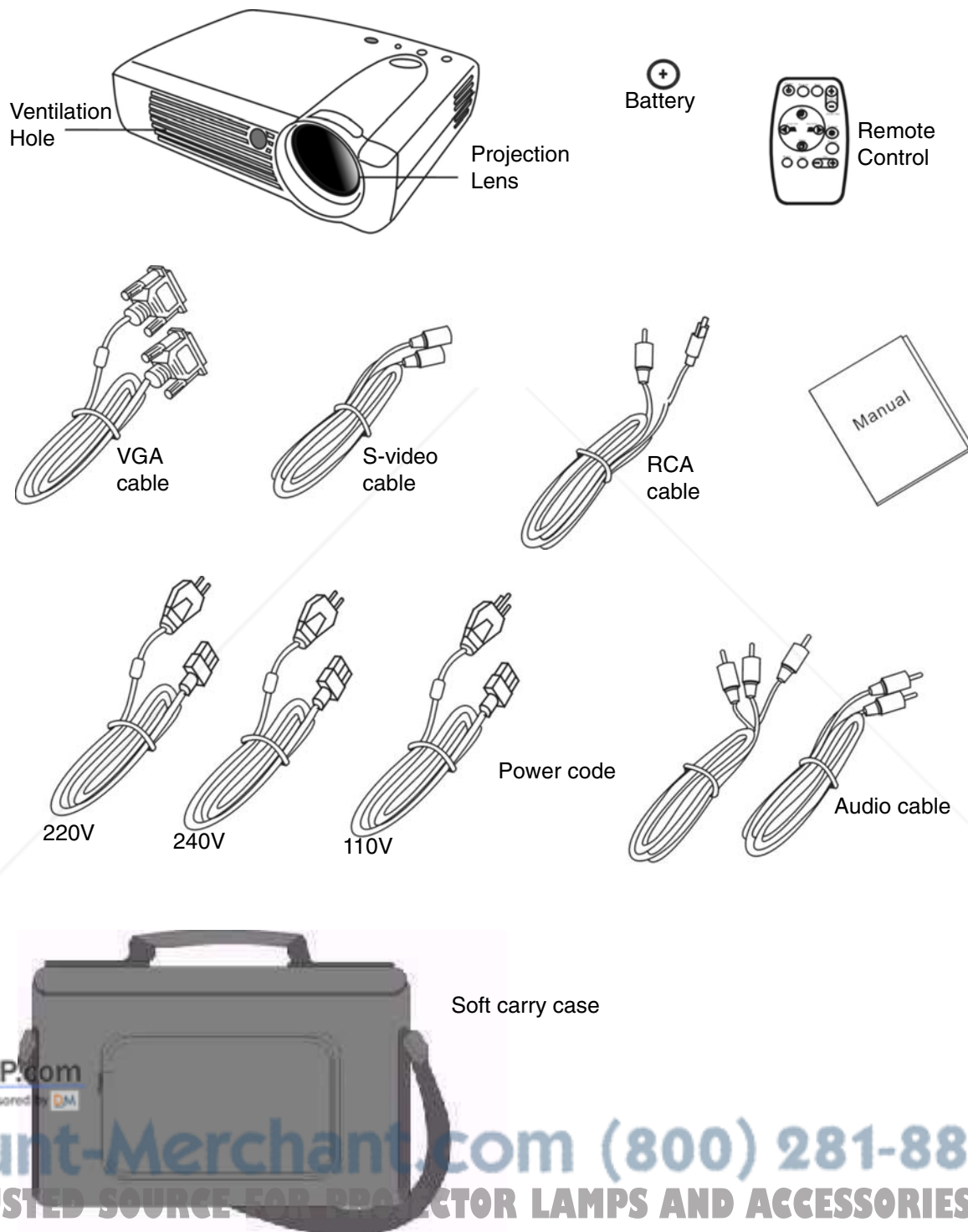

FixYourDLP.com
Sponsored by DM

Discount-Merchant.com (800) 281-8860
THE TRUSTED SOURCE FOR PROJECTOR LAMPS AND ACCESSORIES

Optional Accessories

1. Deluxe carry case
2. Spare Lamp Kit

Projector Description

Projector

- | | |
|-------------------------------------------------------------------------------------------------------------------------------------------------------------------------------------------------------------------------------------------------------------------------------------------------------|----------------------------------------------------------------------------------------------------------------------------------------------------------------------------------------------------------------------------|
| <ol style="list-style-type: none">1. External Control Panel (see next page)2. Projection Lens3. Front Adjustment Feet4. IR Remote Sensor5. Ventilation Grill6. Kensington Lock7. AC Power Cord Input8. S-video Connector | <ol style="list-style-type: none">9. RCA Connector10. D-Sub Connector (for computer/ Input)11. Audio Input12. Rear adjustment Feet13. Lamp Access Door (underneath unit) |
|-------------------------------------------------------------------------------------------------------------------------------------------------------------------------------------------------------------------------------------------------------------------------------------------------------|----------------------------------------------------------------------------------------------------------------------------------------------------------------------------------------------------------------------------|

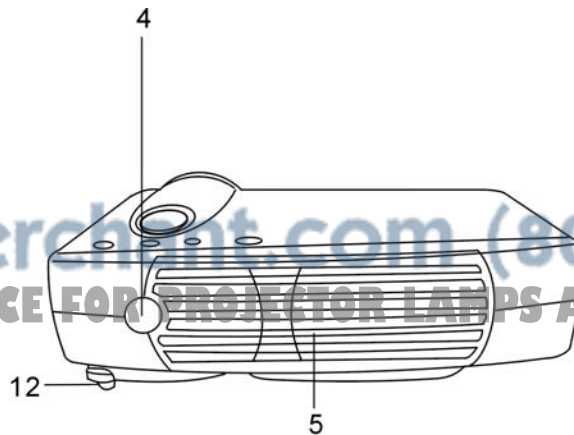
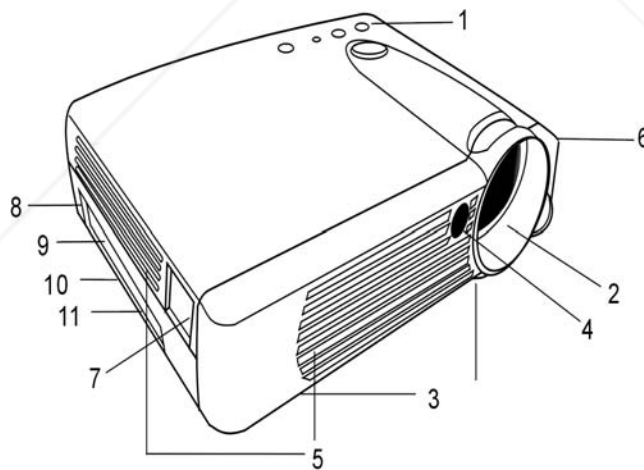

External Control Panel

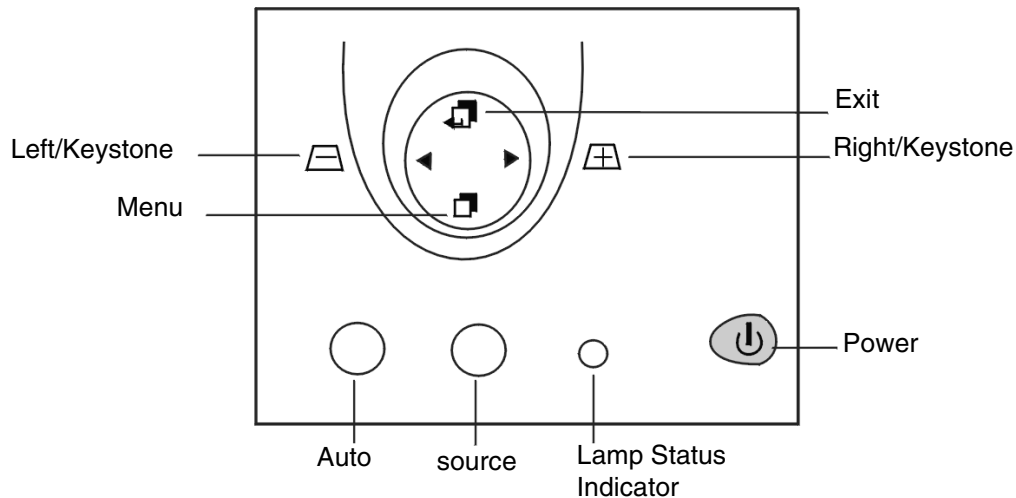

- The External Control Panel is located on the top of the projector, near the rear.
- The **Infrared Remote Receiver (Front and Rear)** allows the projector to accept signals from the remote control. For best results, be sure to aim the control toward this sensor, without any obstructions between the two, and at a distance no greater than 6 meters/19 feet.
- The **Menu** button will display the menu system onscreen. Press **Menu** again to access the sub-menus. The **Left** and **Right** buttons help you navigate among choices and settings in the menus and sub-menus. However, when the onscreen menu is not active, the **Left** and **Right** buttons will function as **Keystone +/-** hot keys.
- Press the **Exit** button to go back to the main menu. Press **Exit** again to leave the menu system.
- The **Status Indicator** will blink or light up when the lamp needs service, cooling or replacement. See “Status Messages” on page 27. for more detailed information.
- When the projector is turned on, the **back-lit Power** button will blink during warm-up and lamp ignition, then stay green to indicate the projector is ready for use.
- Press the **Power** button for 1 second to turn the projector on or off.
- **Auto** key: Automatically fit in the best picture quality for current received signals.
- **Source** key: Select signal sources, PC/ RCA/S-video.

Projector Features

The MP7720 Projector integrates high performance optical engine design and user-friendly electrical design, which means more reliable quality and better experience in projecting with the unit.

The MP7720 Projector offers the following features:

- Intelligent Auto-adjustment to display the best picture quality
- Easy Digital keystone correction as hot keys to make tilted picture normal easily
- Powerful AV function to show high AV capability
- Small and portable unit
- Full-function remote control
- Easy to set up and use
- On screen menus in 7 languages: English, French, German, Italian, Spanish, Portuguese, and Traditional Chinese.
- Color balance control for data/video
- Ultra-high brightness projection lamp
- Ability to display 16.7 million colors

Note: The brightness of your machine will vary depending on the ambient room conditions and contrast/brightness settings.



Discount-Merchant.com (800) 281-8860
THE TRUSTED SOURCE FOR PROJECTOR LAMPS AND ACCESSORIES

Remote Control Description

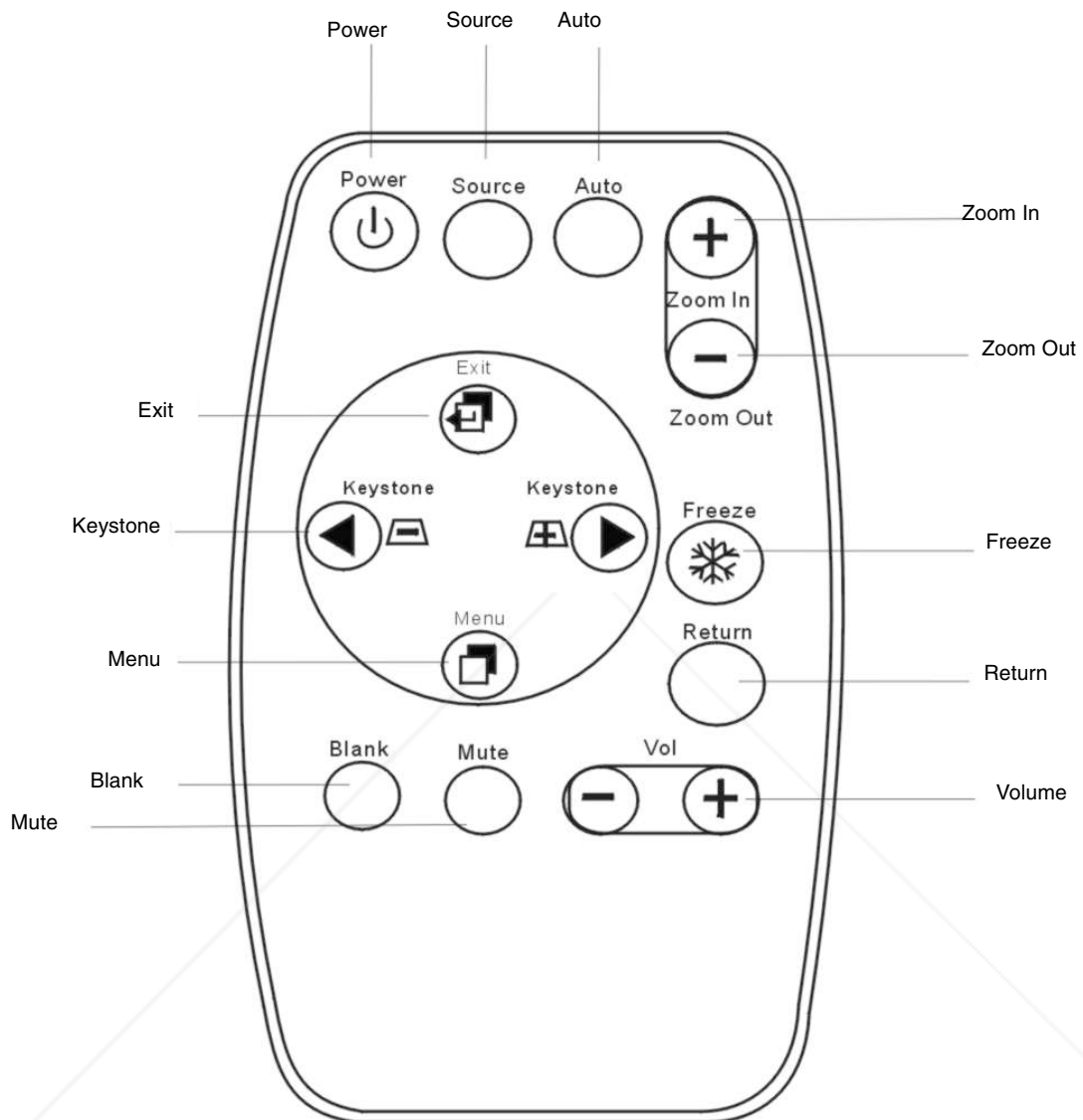

Remote Control Features

The remote control sensors are located in the front/ back of the projector. The distance between the sensor and the remote control unit must be shorter than 6 meters.



Discount-Merchant.com (800) 281-8860
THE TRUSTED SOURCE FOR PROJECTOR LAMPS AND ACCESSORIES

FREEZE

The image will be frozen when the FREEZE button is pressed. A “Pause” icon appears at the lower right of the screen for three seconds during the freeze function. A “Play” icon appears at the lower right of the screen for three seconds when the freeze function is released. To release the freeze function, press the FREEZE button, RETURN button or SOURCE button (when the input source is switched over during display).

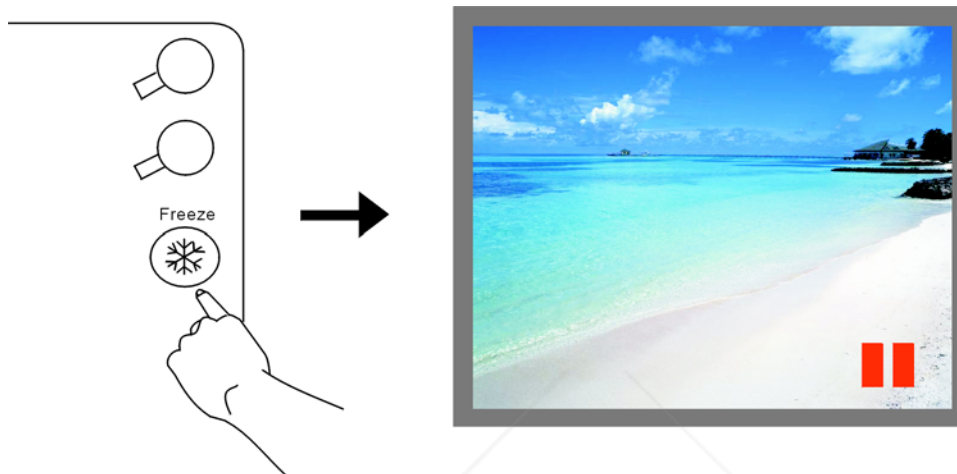

ZOOM IN/OUT

By pressing ZOOM IN +, the center of the picture can be magnified. When the button is pressed again, the picture is further magnified, up to four times the original size. By pressing ZOOM OUT -, the size of the image is reduced. When the button is pressed again, the picture is further reduced until it is restored to the original size. To return to the normal display mode, press the RETURN button. (This function can be used in combination with the FREEZE function.)

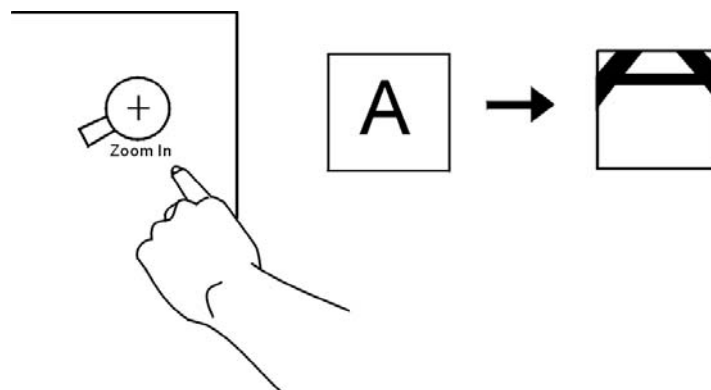

Installing or Replacing Batteries

- Push and slide the battery compartment lid in the direction shown.
- Install one CR2025 battery as indicated by the diagram inside the compartment.
- Position the lid over the compartment and snap it back into place.

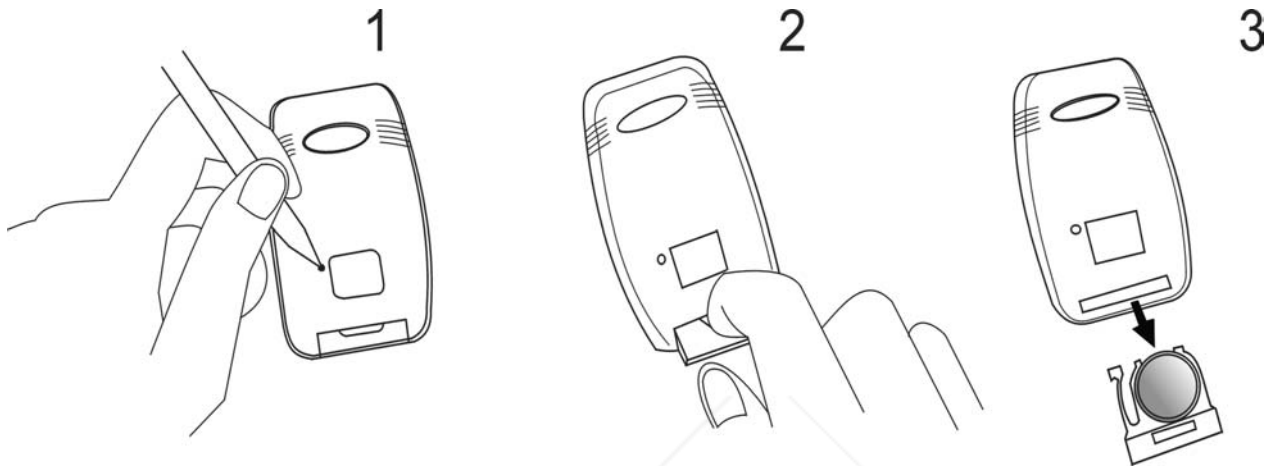

⚠ Caution

Avoid excessive heat and humidity.

Do not mix old and new batteries or different types of batteries.



Discount-Merchant.com (800) 281-8860
THE TRUSTED SOURCE FOR PROJECTOR LAMPS AND ACCESSORIES

Installation

Screen Size

Place the projector at the required distance from the screen according to the desired picture size (see the table below).

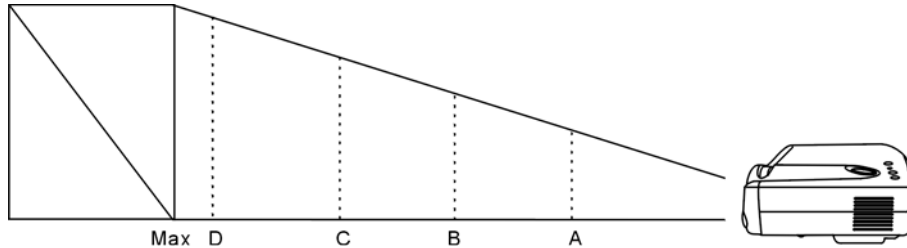

Distance to Screen	4.3 ft./ 1.3 m	6.5 ft./ 2.0 m	8.7 ft./ 2.6 m	10.8 ft./ 3.3 m	13.0 ft./ 4.0 m	16.3 ft./ 5.0 m
Diagonal	40 in./ 101.6 cm	60 in./ 152.4 cm	80 in./ 203.2 cm	100 in./ 254.0 cm	120 in./ 304.8 cm	150 in./ 381.0 cm

Connecting to Various Equipment

It only takes a few seconds to connect the MP7720 projector to your computers/notebook, VCR or other systems. However, for Macintosh users, a Mac adapter is needed for connection. The adapter is an optional accessory.

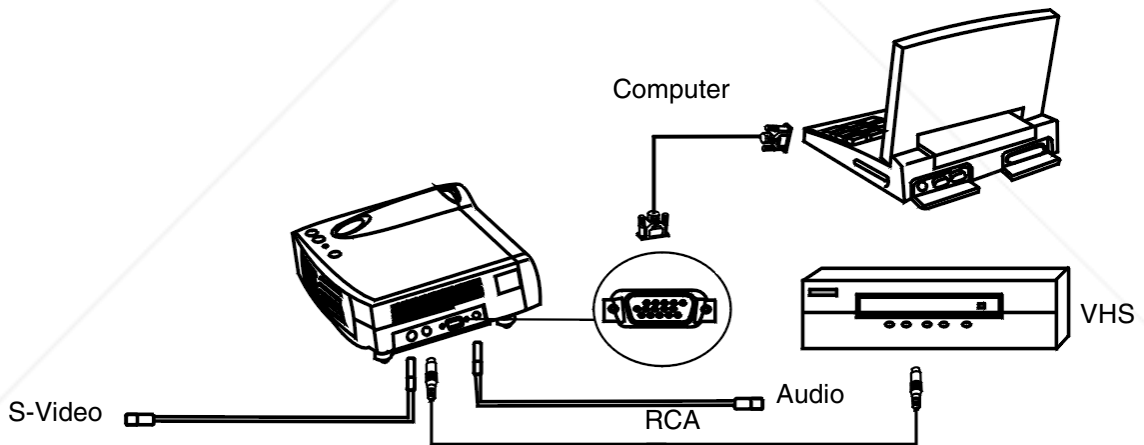

⚠ Caution

Turn off power to all devices before making connections. Never plug anything into the projector or computer while any device is in operation.



FixYourDLP.com

Sponsored by

Discount-Merchant.com (800) 281-8860
THE TRUSTED SOURCE FOR PROJECTOR LAMPS AND ACCESSORIES

Operation

Start Up

1. Plug the power cord into a wall socket.
2. Press the POWER button for 1 second.

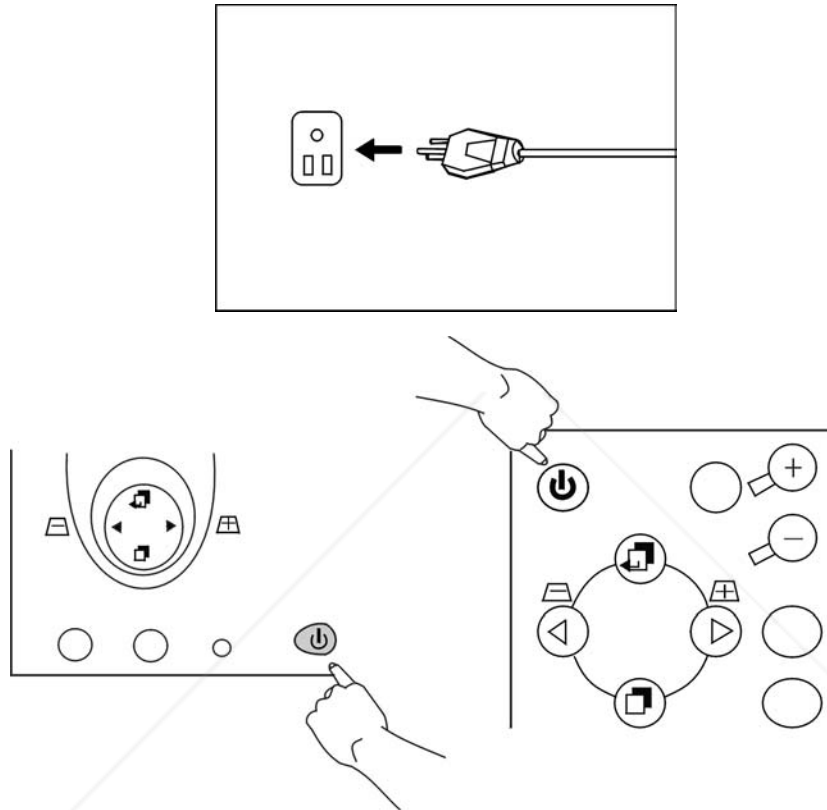

- The back-lit POWER key blinks green and then stays green when power is turned on.
(When power is turned off, there is a 60-second reset period before the POWER button will function again.)

3. Turn on all connected equipment.



Discount-Merchant.com (800) 281-8860
THE TRUSTED SOURCE FOR PROJECTOR LAMPS AND ACCESSORIES

Digital Keystone Correction

Keystoning is when the projected image is noticeably wider on either the top or bottom. To correct this, press KEYSTONE +/- (hot key) on the control panel of the projector or on the remote control, then adjust the sliding bar labeled Keystone, as needed. Pressing the + button will correct keystone at the top of the image. Pressing the - button will correct keystone at the bottom of the image.

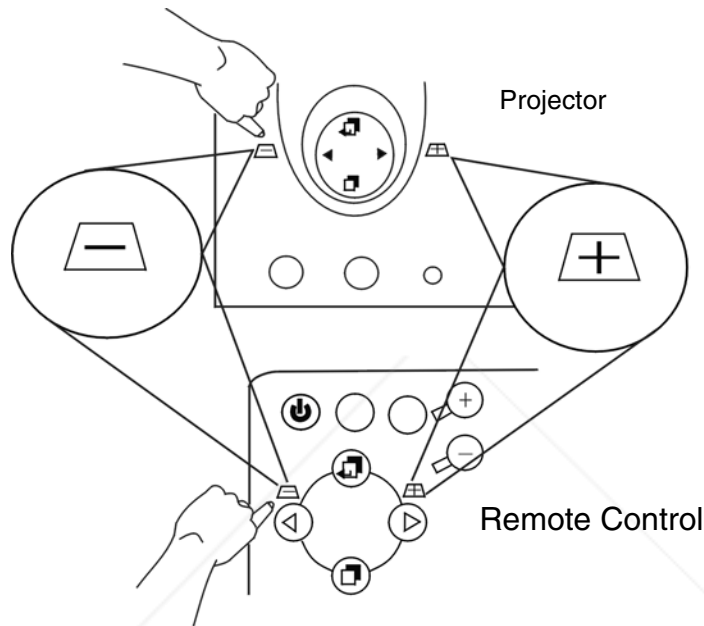

Auto Adjustment

In some cases, you may have to optimize the picture quality manually. To do this, press the AUTO key on the control panel of the projector or on the remote control. Within 3 seconds, the built-in Intelligent Auto Adjustment function of the 3M MP7720 will show you the best picture quality.

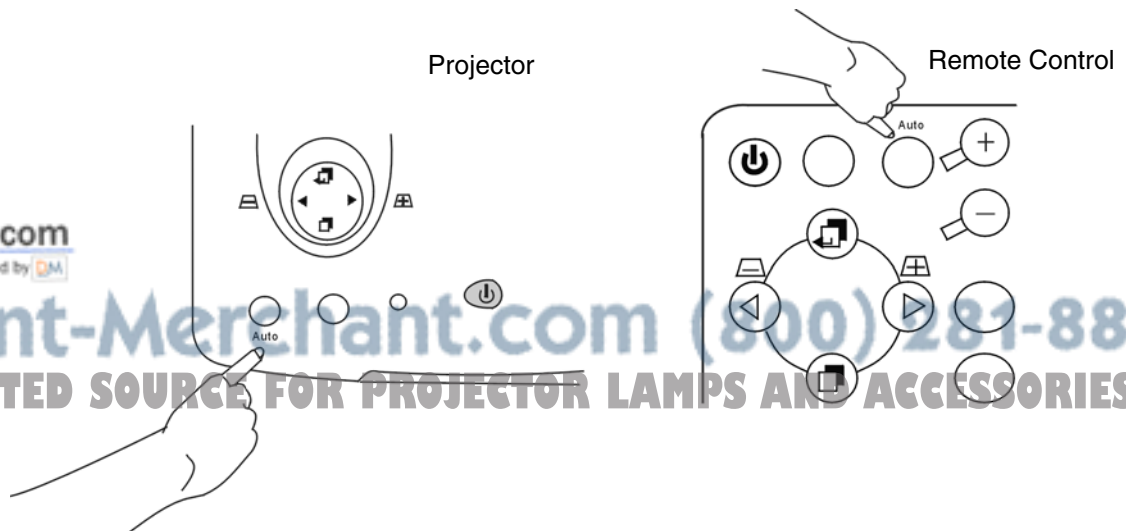

Source Selection

Whenever several input sources are available, press the SOURCE key on the control panel of the projector or the remote control for selection.

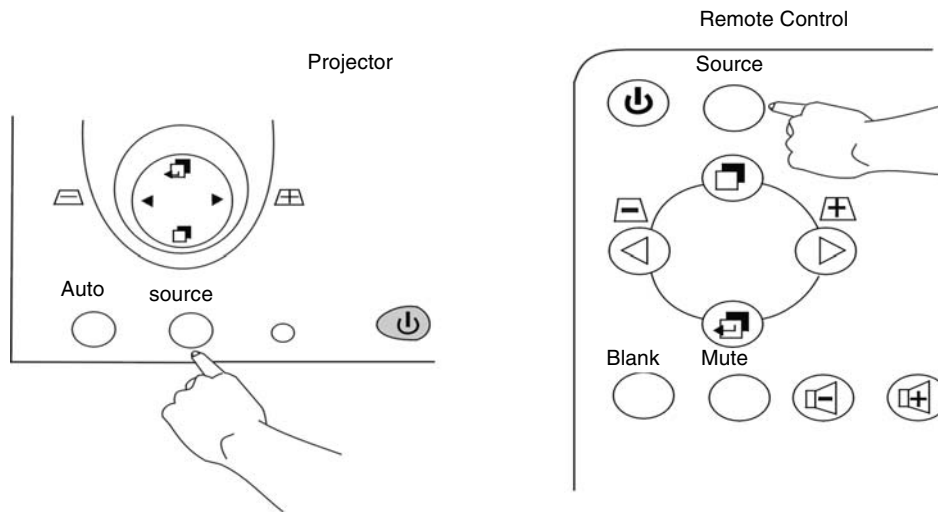

Menu System

Press the **Menu** key and the main menu will display on the screen. Press **Menu** again to display the page items, and press to select the sub-menus. The main menu will disappear automatically if you do not undertake any further action for 10 seconds. Press the **Exit** button to leave the current sub-menu, and press **Exit** again to leave the main menu.

Menu Bar				
Menu Layout	Display	Image	Control	Source
PC input without AV Input	Keystone Brightness Contrast Color Balance	Auto resize Phase Frequency H-position V-position	Language Mirror Auto off Reset	Source Volume Tremble Bass Mute
Video Input	Keystone Brightness Contrast Sharpness	Image Ratio System Color Tint	Language Mirror Auto off Reset	Source Volume Tremble Bass Mute

FixYourDLP.com
Sponsored by DM

Discount-Merchant.com (800) 281-8860
THE TRUSTED SOURCE FOR PROJECTOR LAMPS AND ACCESSORIES

1. Display Menu

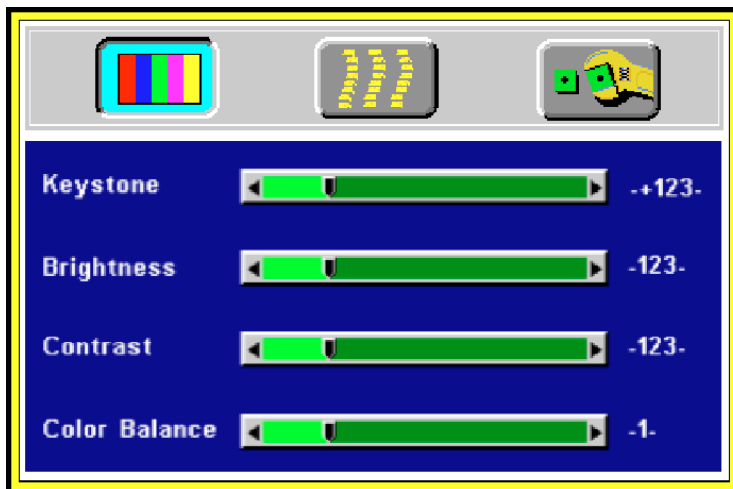

Keystone

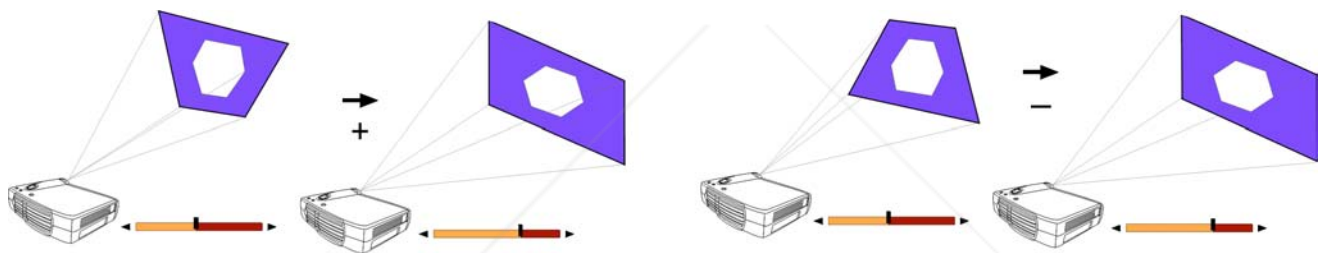

Brightness

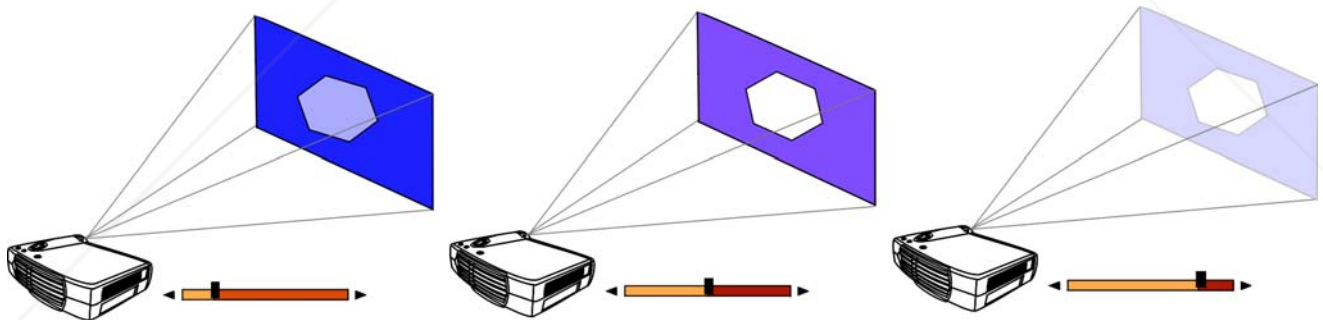

 FixYourDLP.com
Sponsored by 

Discount-Merchant.com (800) 281-8860
THE TRUSTED SOURCE FOR PROJECTOR LAMPS AND ACCESSORIES

Contrast

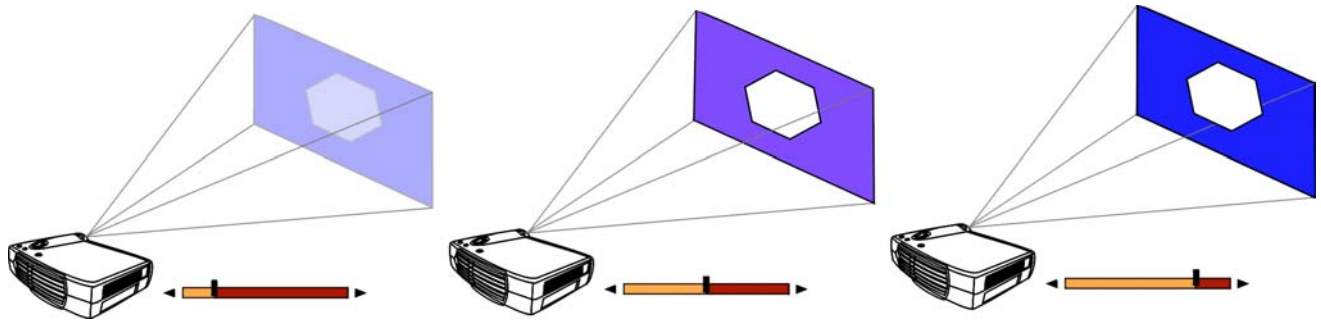

Color Balance

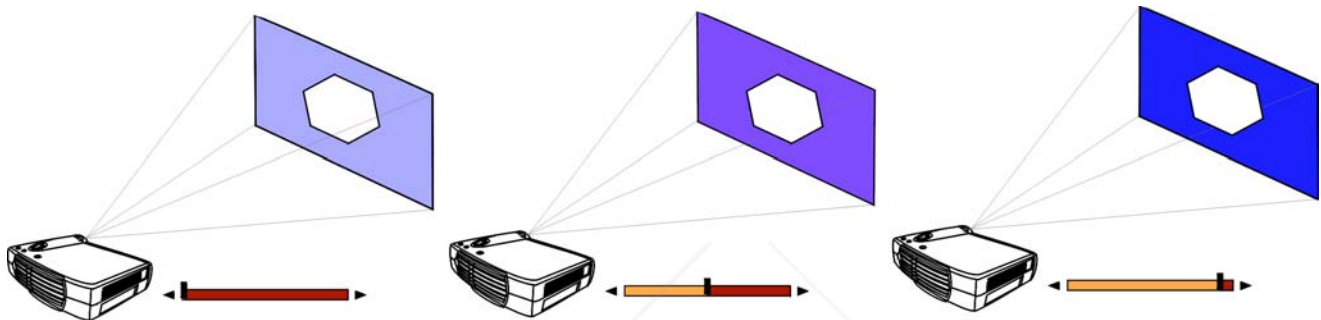

2. Image Menu

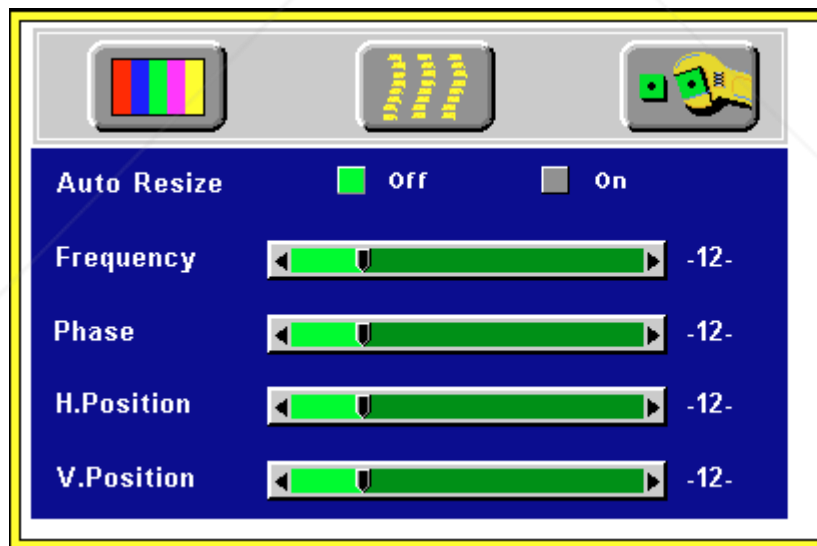

Auto resize

Will automatically adjust the image to fit on the screen.

FixYourDLRoom
Sponsored by DM

Discount-Merchant.com (800) 281-8860
THE TRUSTED SOURCE FOR PROJECTOR LAMPS AND ACCESSORIES

OFF ON

Phase (Auto Resize OFF)



Frequency (Auto Resize OFF)

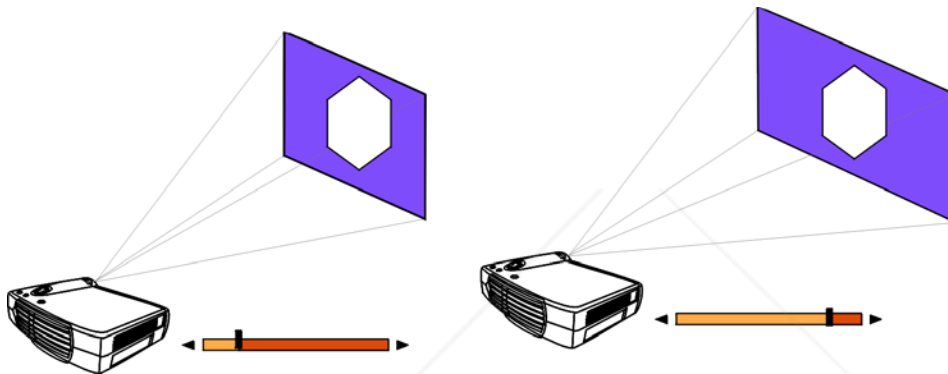

H-position

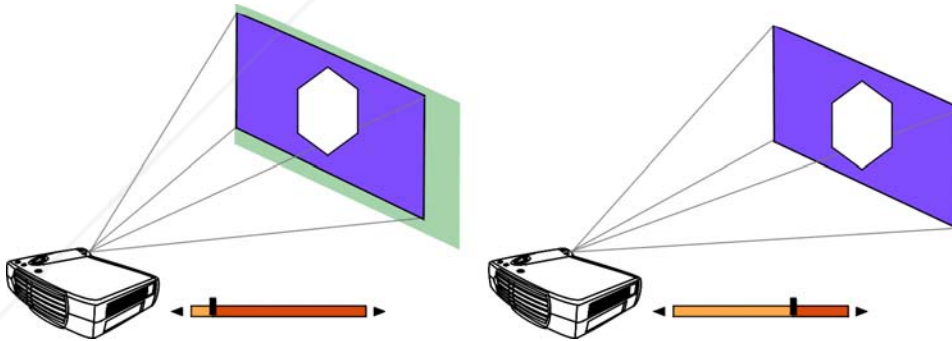

V-position

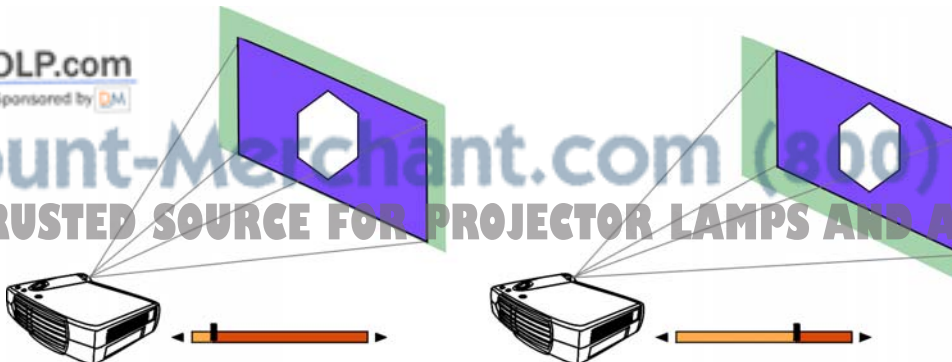

FixYourDLP.com
Sponsored by 3M
Discount-Merchant.com (800) 281-8860
THE TRUSTED SOURCE FOR PROJECTOR LAMPS AND ACCESSORIES

3. Image Sub-menu with AV Input

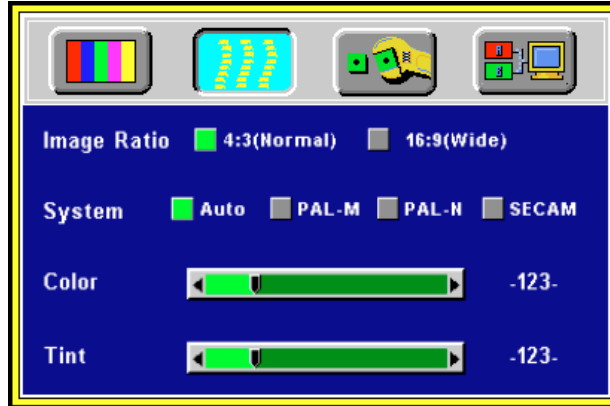

This menu is only available when the input signal is from Video and S-Video.

Image Ratio

4:9 (Normal)

16:9 (Video)

System

Auto

PAL-M

PAL-N

SECAM

Color

Less



More

Tint

Red



Green

4. Control Menu

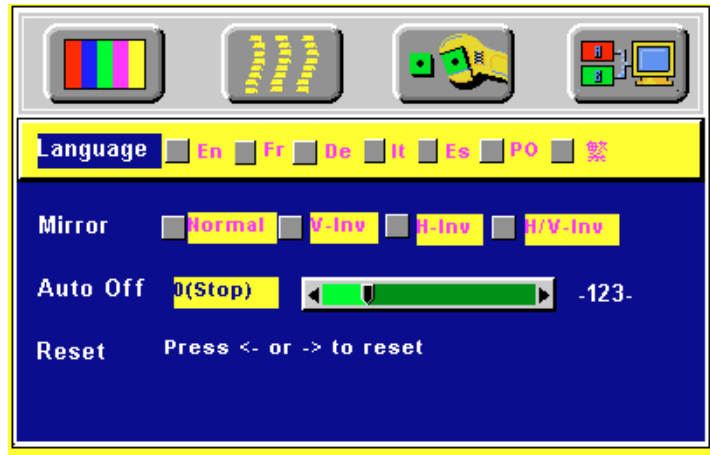

Language

English (En) French (Fr) German (De) Italian (It) Spanish (Es) Portuguese (Po)
Traditional Chinese (TC)

Mirror

Normal V-Inv (Vertically Inverted) H-Inv (Horizontally Inverted) H/V-Inv (Horizontally and Vertically Inverted) will invert image to display properly according to position of projector.



Discount-Merchant.com (800) 281-8860
THE TRUSTED SOURCE FOR PROJECTOR LAMPS AND ACCESSORIES

- 1. Default
- 3. Rear-screen projection

- 2. Ceiling-mounted projection
- 4. Ceiling-mounted and Rear screen projection

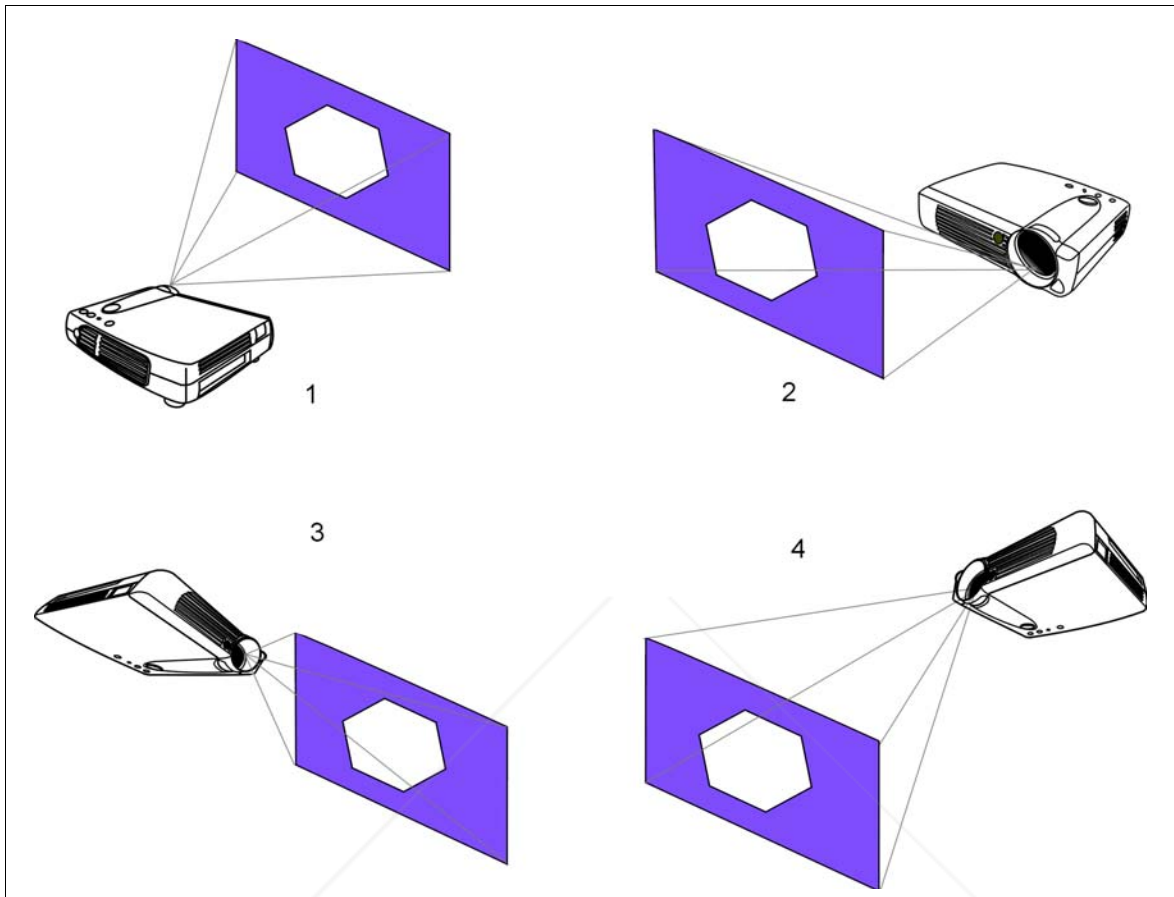

Auto off

Will turn off the power after 60 minutes.

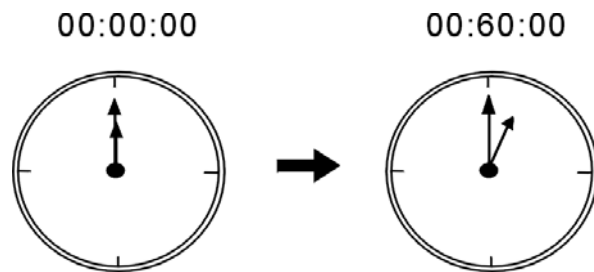

FixYourReset.com
 Sponsored by

Will restore the projector to its factory default settings.

Discount-Merchant.com (800) 281-8860
THE TRUSTED SOURCE FOR PROJECTOR LAMPS AND ACCESSORIES

5. Source Menu

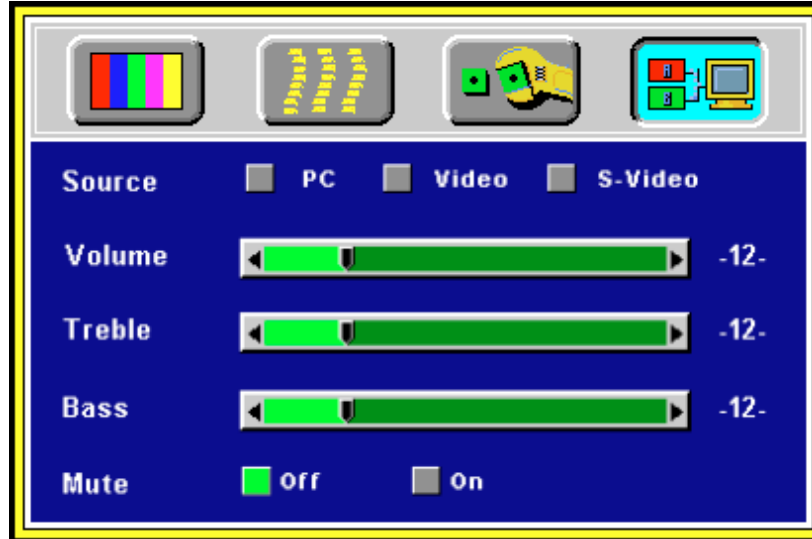

<p>Source</p> <p>PC Video S-Video</p>	
<p>Volume</p>	<p>Treble</p>
<p>Bass</p>	<p>Mute</p> <p>Off On</p>

FixYourDLP.com
Sponsored by 3M

Discount Merchant.com (800) 281-8860

THE TRUSTED SOURCE FOR PROJECTOR LAMPS AND ACCESSORIES

Shutdown

1. Press the POWER button and the lamp will shut down.
2. The fan will continue to run for approximately 60 seconds.

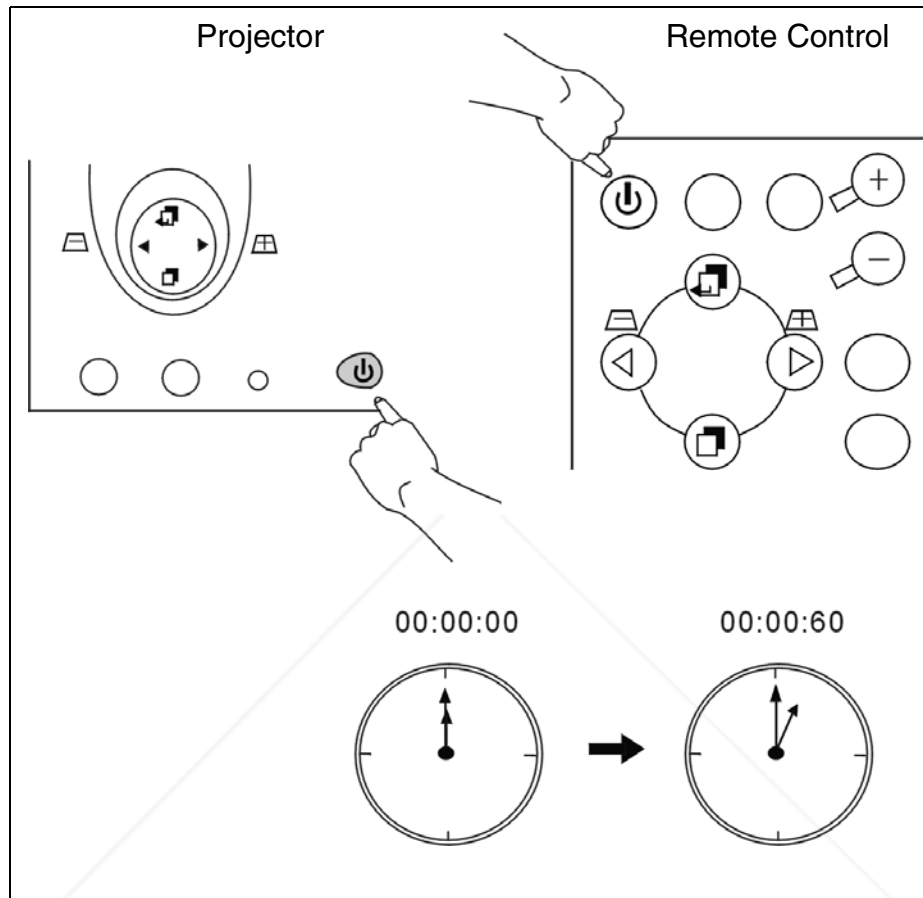

3. Disconnect the power cord from the wall socket.

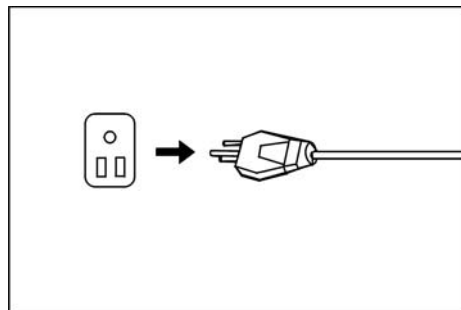

Caution

Please do not unplug the power cord before pressing the POWER button or during the cooling process for 60 seconds after pressing the POWER button.

Maintenance

Lamp Information

Use and Replacement of Lamp

The projector lamp has a normal operating time of approximately 1200 to 1500 hours, called the lamp life. During the normal lamp life, the picture will be bright and the colors clear. If the lamp is used beyond the normal lamp life, the picture will become dark and the colors poor. Always replace lamps with new ones. Using an old lamp in the projector could cause a malfunction. When the power is turned on, the LAMP indicator will light up red or a message will be displayed to indicate when it is time to replace the lamp. Consult your dealer.

Status LED Indicators

Lamp Exceed Service Hours — When this LED lights red continuously, it is warning you that the lamp has exceeded **1500** service hours. Replace the projection lamp immediately.

CHANGE THE LAMP, AND RESET THE LAMP TIMER — The lamp has been in operation for 1200 hours.

CHANGE THE LAMP, THE POWER WILL TURN OFF AFTER 20 HOURS — The lamp has been in operation for 1479 hours, and the power will turn off after 20 more hours.

CHANGE THE LAMP! — The lamp has been in operation for over 1500 hours, and the power will turn off automatically in 10 minutes.

All of these messages will not display for more than 3 minutes, but each message will be displayed whenever you turn on the lamp again.

Lamp is not well attached — When the LED blinks rapidly, it indicates that the lamp is not attached properly.

Temperature is too high — When the projector's internal temperature is too hot to operate safely, the LED blinks slowly for one minute and the lamp turns off automatically.

If the LED light is off, it means that the projector's lamp and temperature are operating under normal conditions.

Caution

The LAMP indicator will light if the lamp becomes too hot. Turn off the power and let the projector cool for 45 minutes. Turn the power back on. If the LAMP indicator still lights red, please contact your dealer.

Lamp Replacement

Caution

To reduce the risk of electrical shock, always turn off the projector and disconnect the power cord before changing the lamp.

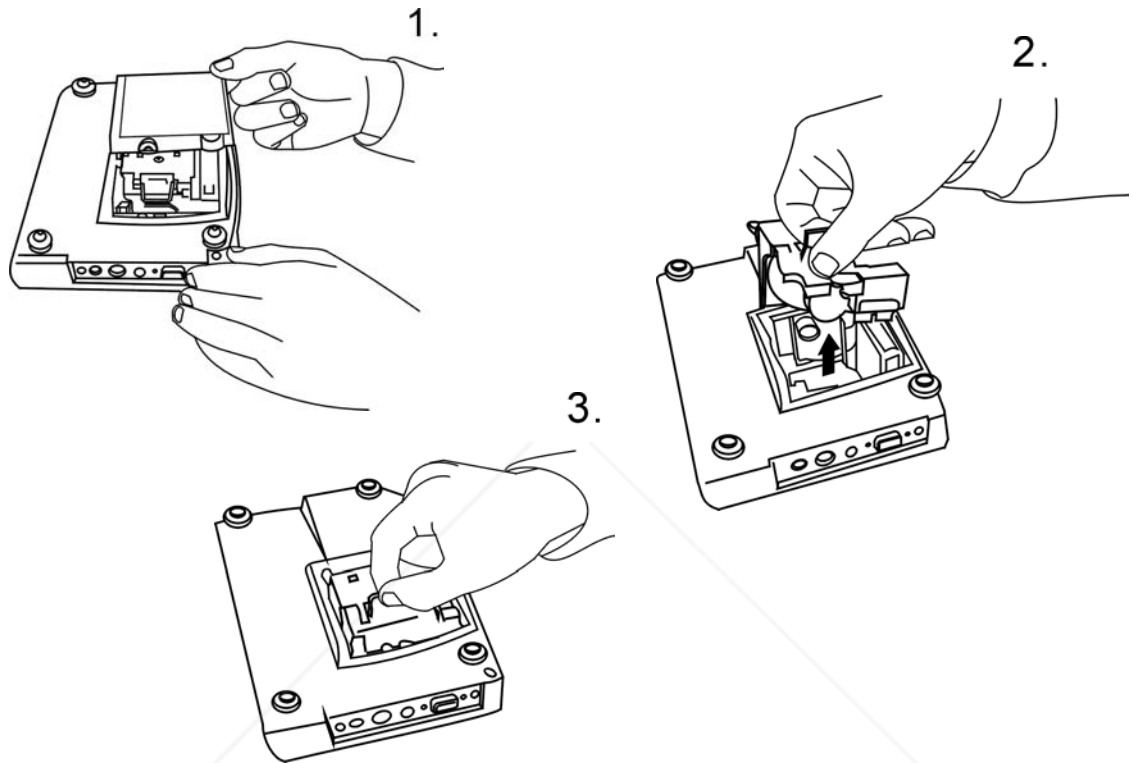

1. Press the **POWER** button to turn the main power switch off and disconnect the power cord from the outlet.
2. Loosen the screw and remove the lamp cover. If the lamp is hot, avoid burns by waiting 45 minutes until the lamp has cooled.
3. Loosen the **3** screws indicated by the arrows below. (It is strongly recommended to use a magnetic-headed screwdriver, if possible. Pull the handle to remove the lamp housing. If the screws are not loosened completely, they could damage your fingers. Do not insert your hand into the box after the lamp is removed. If you touch the optical parts inside, it could cause color unevenness, etc.)
4. Replace the lamp with the new one, insert it in the projector, and tighten the screws. Firmly tighten the lamp screws. Loose screws may cause a bad connection, which may result in a malfunction.
5. Re-install the lamp cover and tighten the screw. Do not turn on the power with the lamp cover removed. Whenever the lamp has been replaced, reset the total operation time of the lamp. Do not reset if the lamp was not replaced, as this could cause breakage.



FixYourDLP.com

Sponsored by

Discount Projector Lamps and Accessories 60
THE TRUSTED SOURCE FOR PROJECTOR LAMPS AND ACCESSORIES

⚠ Caution

To reduce the risk of severe burns, allow the projector to cool for at least 45 minutes before replacing the lamp.

To reduce the risk of cuts to fingers and damage to internal components, use caution when removing lamp glass that has shattered into sharp pieces.

To reduce the risk of cuts to fingers and/or decreasing image quality by touching the lens, do not touch the empty lamp compartment when the lamp has been removed.

This lamp contains mercury. Consult your local hazardous waste regulations and dispose of this lamp in a proper manner.

Resetting Lamp Hours

If you replace the lamp after 1500 hours of operation, please proceed as follows within 10 minutes of powering on.

OSD	FUNCTION
	Press the Exit button on the projector or the remote control for 3 seconds to display the total used lamp time.
	Press the MENU button on the projector or the remote control during the lamp hour message. An adjustment message will appear.
	<ul style="list-style-type: none">• Press ◀ or ▶ to select the setting. To select the default setting, select “Reset” (or “Cancel” to return to the default setting).• Press EXIT to leave.

Service information

Accessories (Included in standard packet)

Description	Part Number
Power Cord (EU)	78-8118-8840-9
Power Cord (US)	78-8118-8838-3
Power Cord (UK)	78-8118-8841-7
Signal Cable	78-8118-8710-4
RCA Cable	DY-0205-1008-6
S-Video cable	78-8118-3238-1
PC - PC Audio Cable	78-8118-8290-7
Audio - PC Audio Cable	DY-0205-1359-3
Remote Control	78-8118-8842-5
3-2 converter	78-8118-8704-7

Description of Part Number (Not Included in Standard Packet)

Description of parts	Part number
Deluxe carry case (hold projector and notebook)	78-6969-9203-7
120W Lamp module	78-6969-9264-6



Discount-Merchant.com (800) 281-8860
THE TRUSTED SOURCE FOR PROJECTOR LAMPS AND ACCESSORIES

Troubleshooting

Common Problems & Solutions

PROBLEMS	TRY THESE SOLUTIONS
NO POWER	<ul style="list-style-type: none">• Plug the power cord into the AC Inlet.• Plug the power cord into the power Inlet.• Wait two minutes after the projector has been turned off before turning the projector back on.
NO PICTURE	<ul style="list-style-type: none">• Check that you have selected the proper input source.• Ensure all cables are connected properly.• Adjust the brightness and contrast.• Remove the lens cap.
IMAGE ISN'T SQUARE ON THE SCREEN	<ul style="list-style-type: none">• Reposition the unit to improve its angle on the screen.• Use the keystone correction function key on the control panel of the projector or the remote control unit.
POOR COLOR	<ul style="list-style-type: none">• Select the correct video system.• Adjust brightness, contrast, or saturation.
IMAGE IS BLURRED	<ul style="list-style-type: none">• Press the Auto key on the control panel of the projector or the remote control unit to get better picture quality.• Adjust the focus.• Reposition the unit to improve its screen angle.• Ensure the distance between the unit and screen is within the adjustment range of the lens.
REMOTE CONTROL DOESN'T WORK	<ul style="list-style-type: none">• Replace the battery with a new one.• Make sure there is no obstacle between the remote control and the unit.• Stand within 4 meters (13 feet) of the unit.• Make sure nothing is blocking the receiver on the control pad.

Status Messages

On Screen Messages	Meaning
SEARCHING	Projector is searching for input.
INPUT SIGNAL DETECTED, ACTIVATING AUTO IMAGE	Projector has identified the input signal and is processing the auto image adjustment.
SYNC IS OUT OF RANGE	Input signal's frequency exceeds that of projector's
CHANGE THE LAMP, AND RESET THE LAMP TIMER	The lamp has been in operation for 1200 hours. Lamp replacement is recommended.
CHANGE THE LAMP, THE POWER WILL TURN OFF AFTER 20 HOURS	The lamp has been in operation for 1479 hours, and the power will turn off after 20 more hours. Replace the lamp as soon as possible.
CHANGE THE LAMP!	The lamp has been in operation for over 1500 hours, and the power will turn off automatically in 10 minutes. Replace the lamp immediately.



Discount-Merchant.com (800) 281-8860
THE TRUSTED SOURCE FOR PROJECTOR LAMPS AND ACCESSORIES

Specifications

Projector specifications

Technical Specifications

Note: All specifications are subject to change without notice.

General

Product name : Personal Projector

Model name MP7720

Optical

Display system 1-CHIP DMD

Lens F/Number: F/2.6 Focal Length: F = 36 mm

Lamp 120W VIP lamp

Electrical

Power supply AC90 ~ 240V, 6.5A ~ 2.9A, 50/60 Hz (Automatic)

Power consumption 200 W (Max)

Mechanical

Dimensions 186 mm (W) x 220 mm (H) x 52 mm (D)

Operating temperature range

Weight 3 lbs

Input terminal

Computer Input: RGB input: D-sub 15-pin (Female)

Video Signal Input S VIDEO: Mini DIN 4-pin terminal

VIDEO: RCA Jack terminal

Audio Signal Input Mini Jack Mono Audio Terminal



1 Watt speaker x 1

Discount-Merchant.com (800) 281-8860

THE TRUSTED SOURCE FOR PROJECTOR LAMPS AND ACCESSORIES

Timing chart

Resolution	H Sync (kHz)	V Sync (kHz)	Remark
640x350	31.5	70.1	
640x400	37.9	85.1	VESA
720x400	31.5	70.0	
720x400	37.9	85.1	VESA
640x480	31.5	60.0	VESA
640x480	37.9	72.8	VESA
640x480	35	66.7	Macintosh
640x480	43.3	85.0	VESA
800x600	35.2	56.3	VESA
800x600	37.9	60.3	VESA
800x600	46.9	75.0	VESA
800x600	48.1	72.2	VESA
800x600	53.7	85.1	VESA
832x624	49.7	74.5	Macintosh
1024x768	48.4	60.0	VESA
1024x768	56.5	70.1	VESA
1024x768	60.0	75.0	VESA
1024x768	68.7	85.0	VESA
1280x1024	64.0	60.0	VESA



Discount-Merchant.com (800) 281-8860
THE TRUSTED SOURCE FOR PROJECTOR LAMPS AND ACCESSORIES

Dimensions

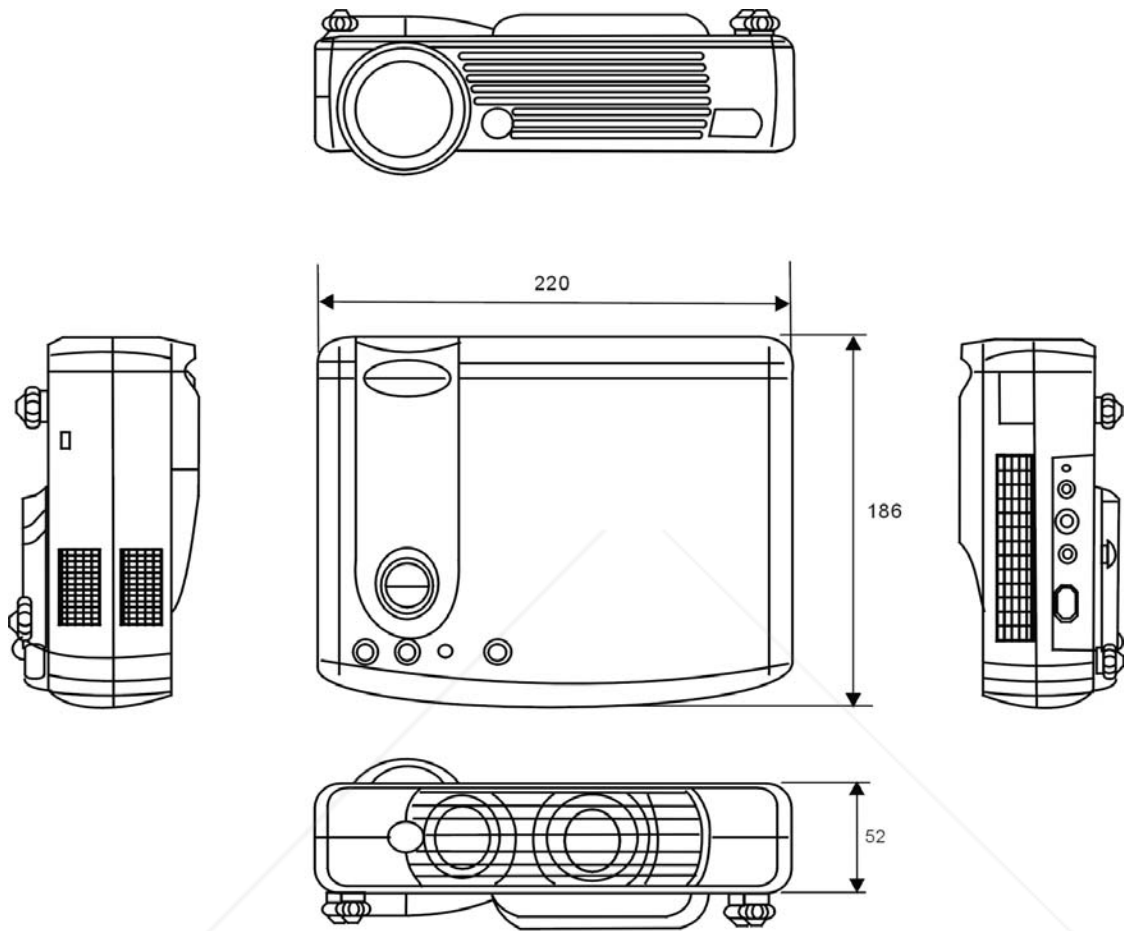

Discount-Merchant.com (800) 281-8860
THE TRUSTED SOURCE FOR PROJECTOR LAMPS AND ACCESSORIES

Important Notice

All statements, technical information, and recommendations related to 3M's products are based on information believed to be reliable, but the accuracy or completeness is not guaranteed. Before using this product, you must evaluate it and determine if it is suitable for your intended application. You assume all risks and liability associated with such use. Any statements related to the product which are not contained in 3M's current publications, or any contrary statements contained on your purchase order shall have no force or effect unless expressly set forth in a written agreement signed by an authorized officer of 3M.

Warranty and Limited Remedy. This product will be free from defects in material and manufacture for a period of two years from the date of purchase. Exclusion to Warranty: The lamps are considered a consumable item and are warranted for 90 days or 180 hours, whichever occurs first. **3M MAKES NO OTHER WARRANTIES, INCLUDING BUT NOT LIMITED TO, ANY IMPLIED WARRANTY OF MERCHANTABILITY OR FITNESS FOR A PARTICULAR PURPOSE.** If this product is defective within the warranty period stated above, your exclusive remedy shall be, at 3M's option, to replace or repair the 3M product or refund the purchase price of the 3M product.

Limitation of Liability. Except where prohibited by law, 3M will not be liable for any loss or damage arising from this 3M product, whether direct, indirect, special, incidental or consequential regardless of the legal theory asserted.

Let us help you make the most of your next presentation. We offer everything from presentation supplies to tips for better meetings. And we're the only transparency manufacturer that offers a recycling program for your used transparencies. For late-breaking news, handy reference and free product samples, call us toll-free in the continental United States and Canada, 24 hours a day, or visit our Internet Website.



FixYourDLP.com
Sponsored by

800-328-1371

<http://www.3m.com/meetings>
e-mail: meetings@mmm.com

Discount-Merchant.com (800) 281-8860
THE TRUSTED SOURCE FOR PROJECTOR LAMPS AND ACCESSORIES

3M Austin Center
Building A145-5N-01
6801 River Place Blvd.
Austin, TX 78726-9000

3M Canada
P.O. Box 5757
London, Ontario
N6A 4T1

3M Mexico, S.A. de C.V.
Apartado Postal 14-139
Mexico, D.F. 07000
Mexico

3M Europe
Boulevard de l'Oise
95006 Cerge Pontoise Cedex
France

Litho in USA
Copyright © 2001 3M IPC.
All Rights Reserved
78-6970-9066-6 Rev. B





Disclaimer

This user manual is provided as a free service by FixYourDLP.com. FixYourDLP is in no way responsible for the content of this manual, nor do we guarantee its accuracy. FixYourDLP does not make any claim of copyright and all copyrights remain the property of their respective owners.

About FixYourDLP.com

FixYourDLP.com (<http://www.fixyourdlp.com>) is the World's #1 resource for media product news, reviews, do-it-yourself guides, and manuals.

Informational Blog: <http://www.fixyourdlp.com>

Video Guides: <http://www.fixyourdlp.com/guides>

User Forums: <http://www.fixyourdlp.com/forum>

FixYourDLP's Fight Against Counterfeit Lamps:

<http://www.fixyourdlp.com/counterfeits>

Sponsors:

RecycleYourLamp.org – Free lamp recycling services for used lamps:

<http://www.recycleyourlamp.org>

Lamp Research - The trusted 3rd party lamp research company:

<http://www.lampresearch.com>

Discount-Merchant.com – The worlds largest lamp distributor:

<http://www.discount-merchant.com>



FixYourDLP.com

Sponsored by 