



Disclaimer

This user manual is provided as a free service by FixYourDLP.com. FixYourDLP is in no way responsible for the content of this manual, nor do we guarantee its accuracy. FixYourDLP does not make any claim of copyright and all copyrights remain the property of their respective owners.

About FixYourDLP.com

FixYourDLP.com (<http://www.fixyourdlp.com>) is the World's #1 resource for media product news, reviews, do-it-yourself guides, and manuals.

Informational Blog: <http://www.fixyourdlp.com>

Video Guides: <http://www.fixyourdlp.com/guides>

User Forums: <http://www.fixyourdlp.com/forum>

FixYourDLP's Fight Against Counterfeit Lamps:

<http://www.fixyourdlp.com/counterfeits>

Sponsors:

RecycleYourLamp.org – Free lamp recycling services for used lamps:

<http://www.recycleyourlamp.org>

Lamp Research - The trusted 3rd party lamp research company:

<http://www.lampresearch.com>

Discount-Merchant.com – The worlds largest lamp distributor:

<http://www.discount-merchant.com>



FixYourDLP.com

Sponsored by 

SONY[®]

2-684-389-11 (1)

Data Projector

Operating Instructions

VPL-CX63
VPL-CX61



Discount-Merchant.com (800) 281-8860
© 2006 Sony Corporation
THE TRUSTED SOURCE FOR PROJECTOR LAMPS AND ACCESSORIES

VPL-CX63/CX61
2-684-389-11 (1)

WARNING

To reduce the risk of fire or electric shock, do not expose this apparatus to rain or moisture.

To avoid electrical shock, do not open the cabinet. Refer servicing to qualified personnel only.

WARNING

THIS APPARATUS MUST BE EARTHED.

IMPORTANT

The nameplate is located on the bottom.

WARNING

This unit has no power switch. When installing the unit, incorporate a readily accessible disconnect device in the fixed wiring, or connect the power cord to socket-outlet which must be provided near the unit and easily accessible. If a fault should occur during operation of the unit, operate the disconnect device to switch the power supply off, or disconnect the power cord.

CAUTION

Danger of explosion if battery is incorrectly replaced. Replace only with the same or equivalent type recommended by the manufacturer. Dispose of used batteries according to the manufacturer's instructions.

For the customers in the USA

This equipment has been tested and found to comply with the limits for a Class B digital device, pursuant to Part 15 of the FCC Rules. These limits are designed to provide reasonable protection against harmful interference in a residential installation. This equipment generates, uses, and can radiate radio frequency energy and, if not installed and used in accordance with the instructions, may cause harmful interference to radio communications. However, there is no guarantee that interference will not occur in a particular installation. If this equipment

does cause harmful interference to radio or television reception, which can be determined by turning the equipment off and on, the user is encouraged to try to correct the interference by one or more of the following measures:

- Reorient or relocate the receiving antenna.
- Increase the separation between the equipment and receiver.
- Connect the equipment into an outlet on a circuit different from that to which the receiver is connected.
- Consult the dealer or an experienced radio/TV technician for help.

You are cautioned that any changes or modifications not expressly approved in this manual could void your authority to operate this equipment.

All interface cables used to connect peripherals must be shielded in order to comply with the limits for a digital device pursuant to Subpart B of Part 15 of FCC Rules.

If you have any questions about this product, you may call:
Sony Customer Information Service Center
1-800-222-7669 or <http://www.sony.com/>

Declaration of Conformity

Trade Name: SONY
Model: VPL-CX63/CX61
Responsible Party: Sony Electronics Inc.
Address: 16530 Via Esprillo,
San Diego, CA 92127 U.S.A.
Telephone Number: 858-942-2230

This device complies with Part 15 of the FCC Rules. Operation is subject to the following two conditions: (1) This device may not cause harmful interference, and (2) this device must accept any interference received, including interference that may cause undesired operation.

WARNING: THIS WARNING IS APPLICABLE FOR USA ONLY.
If used in USA, use the UL LISTED power cord specified below.



Sponsored by

Discount-Merchant.com (800) 281-8860
THE TRUSTED SOURCE FOR PROJECTOR LAMPS AND ACCESSORIES

DO NOT USE ANY OTHER POWER
CORD.

Plug Cap Parallel blade with ground pin
(NEMA 5-15P Configuration)
Cord Type SJT, three 16 or 18 AWG
wires
Length Minimum 1.5m (4 ft .11in.), Less
than 2.5 m (8 ft .3 in.)
Rating Minimum 10A, 125V

Using this unit at a voltage other than 120V
may require the use of a different line cord or
attachment plug, or both.

To reduce the risk of fire or electric shock,
refer servicing to qualified service
personnel.

**WARNING: THIS WARNING IS
APPLICABLE FOR OTHER
COUNTRIES.**

1. Use the approved Power Cord (3-core
mains lead) / Appliance Connector / Plug
with earthing-contacts that conforms to
the safety regulations of each country if
applicable.
2. Use the Power Cord (3-core mains lead) /
Appliance Connector / Plug conforming
to the proper ratings (Voltage, Ampere).

If you have questions on the use of the above
Power Cord /Appliance Connector /Plug,
please consult a qualified service personnel.

Voor de klanten in Nederland



Gooi de batterij niet weg maar
lever deze in als klein chemisch
afval (KCA).

Disposal of Old Electrical & Electronic Equipment (Applicable in the European Union and other European countries with separate collection systems)



This symbol on the product or
on its packaging indicates that
this product shall not be treated
as household waste. Instead it
shall be handed over to the
applicable collection point for
the recycling of electrical and
electronic equipment. By ensuring this
product is disposed of correctly, you will
help prevent potential negative
consequences for the environment and
human health, which could otherwise be
caused by inappropriate waste handling of
this product. The recycling of materials will
help to conserve natural resources. For more
detailed information about recycling of this
product, please contact your local city office,
your household waste disposal service or the
shop where you purchased the product.

Table of Contents

Overview

| | |
|--|----|
| Precautions | 5 |
| Notes on Installation and Usage | 6 |
| Unsuitable Installation | 6 |
| Unsuitable Conditions | 7 |
| Usage at High Altitude | 7 |
| About the Supplied Manuals | 8 |
| Features | 8 |
| Location and Function of Controls | 9 |
| Top/Front/Left Side | 9 |
| Rear/Right Side/Bottom | 9 |
| Control Panel | 10 |
| Connector Panel | 11 |
| Remote Commander | 12 |

Projecting the Picture

| | |
|--------------------------------|----|
| Installing the Projector | 14 |
| Connecting the Projector | 15 |
| Connecting a Computer | 15 |
| Connecting a VCR | 16 |
| Projecting | 17 |
| Turning Off the Power | 19 |

Convenient Functions

| | |
|--|----|
| Selecting the Menu Language | 20 |
| Security Lock | 21 |
| Other Functions | 22 |
| Switching from Auto Adjustments Function to Manual Adjustments | 22 |
| Off & Go Function | 22 |
| Direct Power On/Off Function ... | 22 |
| Effective Tools for Your Presentation | 23 |

Adjustments and Settings Using a Menu

| | |
|----------------------------------|----|
| Using a MENU | 24 |
| The PICTURE SETTING Menu | 26 |
| The INPUT SETTING Menu | 27 |
| About the Preset Memory No. | 28 |
| The SET SETTING Menu | 29 |
| The MENU SETTING Menu | 31 |
| The INSTALL SETTING Menu | 32 |
| The INFORMATION Menu | 34 |

Maintenance

| | |
|-------------------------------|----|
| Replacing the Lamp | 36 |
| Cleaning the Air Filter | 38 |

Others

| | |
|--|----|
| Troubleshooting | 39 |
| Messages List | 42 |
| Specifications | 44 |
| Installation Diagram | 50 |
| Floor Installation (Front Projection) | 50 |
| Ceiling Installation (Front Projection) | 52 |
| Dimensions | 54 |
| Index | 56 |

► **Overview**

Precautions

Safety

- Check that the operating voltage of your unit is identical with the voltage of your local power supply.
- Should any liquid or solid object fall into the cabinet, unplug the unit and have it checked by qualified personnel before operating it further.
- Unplug the unit from the wall outlet if it is not to be used for several days.
- To disconnect the cord, pull it out by the plug. Never pull the cord itself.
- The wall outlet should be near the unit and easily accessible.
- The unit is not disconnected to the AC power source (mains) as long as it is connected to the wall outlet, even if the unit itself has been turned off.
- Do not look into the lens while the lamp is on.
- Do not place your hand or objects near the ventilation holes. The air coming out is hot.
- Be careful not to get your fingers caught in the adjuster.
- Do not spread a cloth or paper under the unit.

Illumination

- To obtain the best picture, the front of the screen should not be exposed to direct lighting or sunlight.
- Ceiling-mounted spot lighting is recommended. Use a cover over fluorescent lamps to avoid lowering the contrast ratio.
- Cover any windows that face the screen with opaque draperies.
- It is desirable to install the unit in a room where floor and walls are not of light-reflecting material. If the floor and walls are of reflecting material, it is recommended that the carpet and wall paper be changed to a dark color.

Preventing internal heat build-up

After you turn off the power with the I/⏻ key, do not disconnect the unit from the wall outlet while the cooling fan is still running.

Caution

The unit is equipped with ventilation holes (intake) and ventilation holes (exhaust). Do not block or place anything near these holes, or internal heat build-up may occur, causing picture degradation or damage to the projector.

Cleaning

- To keep the cabinet looking new, periodically clean it with a soft cloth. Stubborn stains may be removed with a cloth lightly dampened with a mild detergent solution. Never use strong solvents, such as thinner, benzene, or abrasive cleansers, since these will damage the cabinet.
- Avoid touching the lens. To remove dust on the lens, use a soft dry cloth. Do not use a damp cloth, detergent solution, or thinner.
- Clean the filter at regular intervals.

LCD data projector

- This LCD data projector is manufactured using high-precision technology. You may, however, see tiny black points and/or bright points (red, blue, or green) that appear continuously on the LCD data projector. This is a normal result of the manufacturing process and does not indicate a malfunction

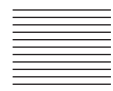

Overview

Notes on Installation and Usage

Unsuitable Installation

Do not install the projector in the following situations. **Installation in these situations or locations may cause a malfunction or damage** to the unit.

Poorly ventilated locations

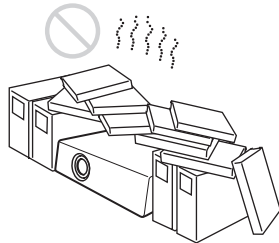

- Allow adequate air circulation to prevent internal heat build-up. Do not place the unit on surfaces (rugs, blankets, etc.) or near materials (curtains, draperies) that may block the ventilation holes. When internal heat builds up due to blockage of ventilation holes, the temperature sensor will function, and the power will be turned off automatically.
- Leave space of more than 30 cm (11 ⁷/₈ inches) around the unit.
- Be careful not to allow the ventilation holes to inhale tiny objects such as pieces of paper or clumps of dust.

Hot and humid

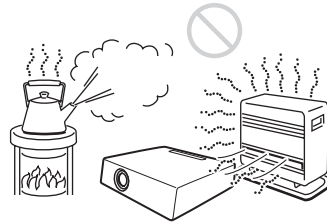

- Avoid installing the unit in a location where the temperature or humidity is very high, or the temperature is very low.
- To avoid moisture condensation, do not install the unit in a location where the temperature may rise rapidly.

Locations subject to direct cool or warm air from an air-conditioner

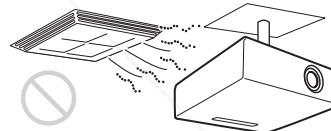

Installing the projector in such a location may cause a malfunction of the unit due to moisture condensation or a rise in temperature.

Near a heat or smoke sensor

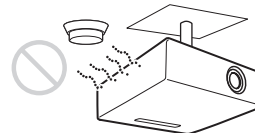

Malfunction of the sensor may occur.

Very dusty, extremely smoky locations

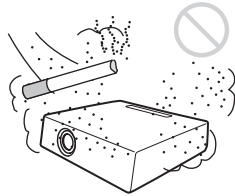

Avoid installing the unit in a very dusty or extremely smoky environment. Otherwise, the air filter will become obstructed, and this may cause a malfunction of the unit or damage it. Dust preventing the air passing through the filter may cause a rise in the internal temperature of the unit. Clean the filter periodically.

Unsuitable Conditions

Do not use the projector under the following conditions.

Standing the unit upright on one side

Avoid using the unit standing upright on its side. It may cause malfunction.

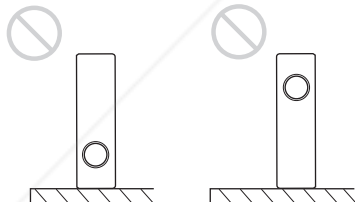

Tilting the unit to the right or left

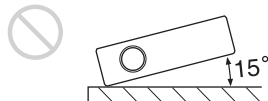

Avoid tilting the unit to an angle of 15°, and avoid installing the unit in any way other than placing it on a level surface or suspending it from the ceiling. Such an installation may cause color shading or shorten the lamp life excessively.

Blocking the ventilation holes

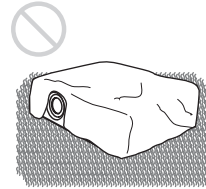

Avoid using a thick-piled carpet or anything that covers the ventilation holes (exhaust/intake); otherwise, internal heat may build up.

Placing a blocking object just in front of the lens

Do not place any object just in front of the lens that may block the light during projection. Heat from the light may damage the object. Use the PIC MUTING key on the Remote Commander to cut off the picture.

Usage at High Altitude

When using the projector at an altitude of 1,500 m or higher, turn on “High Altitude Mode” in the INSTALL SETTING menu. Failing to set this mode when using the projector at high altitudes could have adverse effects, such as reducing the reliability of certain components.

Note on the screen

When using a screen with an uneven surface, a striped pattern may rarely appear on the screen depending on the distance between the screen and the projector or the zooming magnification settings used. This is not a malfunction of the projector.



Overview

About the Supplied Manuals

The following manuals are supplied with this unit.

Safety Regulations (separately printed manual)

This manual describes important notes and cautions to which you have to pay attention when handling and using this product.

Quick Reference Manual (separately printed manual)

This manual describes basic operations for projecting pictures after you have made the required connections.

Operating Instructions (on the CD-ROM) (this manual)

This Operating Instructions describes the setup and operations of this unit. Model VPL-CX63 is used for illustration purposes throughout this manual. Any differences in operation are indicated in the text, for example, "VPL-CX63 only."

Note

You must have Adobe Acrobat Reader 5.0 or higher is installed to read the Operating Instructions stored on the CD-ROM.

Features

High brightness, high picture quality

High brightness

Sony's unique optical system provides high-efficiency ensuring a light output of 3000 ANSI lumen (VPL-CX63) or 2500 ANSI lumen (VPL-CX61).

High picture quality

Three super-high-aperture 0.79-inch XGA panels with approximately 790,000 effective pixels, produce a resolution of 1024 × 768 dots (horizontal/vertical) for RGB input, and 750 horizontal TV lines for video input.

Quiet presentation environment

Low fan noise reduces distraction allowing you to run an optimum presentation even in a quiet environment.

Easy setup and simple operation

Powered zoom/focus equipped

The projector is equipped with a powered zoom and powered focus lens, allowing you to adjust the size and focus of an image with the Remote Commander away from the projector.

Short focal lens

The projection distance is very short, approximately 2.4 m (7.8 feet), when projecting an 80-inch image, which allows projection on a larger screen even in a limited space.

V keystone correction

The projector supports the V keystone (Vertical trapezoidal distortion) correction feature, which automatically corrects vertical trapezoidal distortion of the image caused when the projector is tilted upward.

Off & Go feature

The cooling fan built into the projector will work even after the power is turned off and the power cord is disconnected. This enables

you to move the projector to another location immediately after turning it off.

Versatile installation capability

Capable of floor, ceiling or tilt installation

In addition to the front floor or ceiling installation, you can install the projector by tilting it 90 degrees at the rear or 90 degrees in front.

Direct Power On/Off function

The AC power of the entire system can be directly turned on/off with a breaker or other switch without pressing the power key on the projector.

Security Functions

Security lock

This function makes it possible to prevent projection of a picture on the screen unless the required password is entered when the projector is turned on.

Panel key lock

This function locks all the keys on the control panel of the projector, allowing use of the keys on the Remote Commander. This prevents the projector from operating incorrectly.

About Trademarks

- Adobe Acrobat is a trademark of Adobe Systems Incorporated.
- Windows is a registered trademark of Microsoft Corporation in the United States and/or other countries.
- VGA, SVGA, XGA and SXGA are registered trademarks of the International Business Machines Corporation, U.S.A.
- Kensington is a registered trademark of Kensington Technology Group.
- Macintosh is a registered trademark of Apple Computer, Inc.
- VESA is a registered trademark of the Video Electronics Standard Association.
- Display Data Channel is a trademark of the Video Electronics Standard Association.

Location and Function of Controls

Top/Front/Left Side

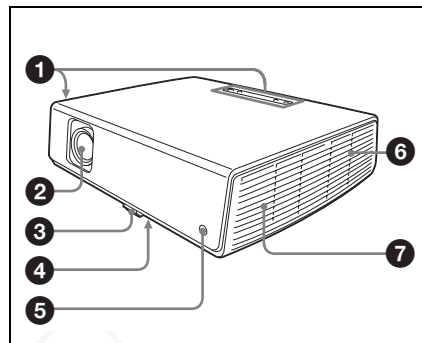

Rear/Right Side/Bottom

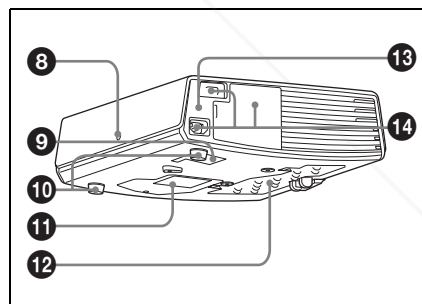

1 Control panel

For details, see "Control Panel" on page 10.

2 Lens

Remove the lens cap before projection.

3 Adjuster

4 Adjuster adjustment button

For details, see "Using the adjuster" on page 18.

5 Front remote control detector

6 Ventilation holes (exhaust)

Overview

- 7 Speaker
- 8 Rear remote control detector
- 9 Ventilation holes (intake)
- 10 Adjusters (hind pad)
Turn the appropriate adjuster to the right or left for minor tilt adjustment of the projected picture.
- 11 Ventilation holes (intake)/Lamp cover
- 12 Ventilation holes (intake)/Air filter cover

Notes

- Do not place anything near the ventilation holes as this may cause internal heat build-up.
- Do not place your hand near the ventilation holes as this may cause injury.
- To maintain optimal performance, **clean the air filter every 1000 hours.**

For details, see "Cleaning the Air Filter" on page 38.

- 13 Security lock
Connects to an optional security cable (from Kensington).
Web page address:
<http://www.kensington.com/>
- 14 Connector Panel
For details, see "Connector Panel" on page 11.

Control Panel

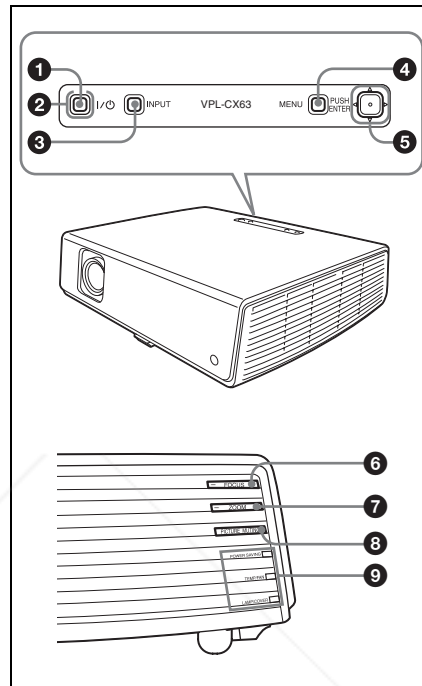

- 1 I/O (On/Standby) key
Turns on the projector when it is in standby mode. When you push this key, the ON/STANDBY indicator around the I/O key flashes in green until the projector is ready to operate.
- 2 ON/STANDBY indicator (located around the I/O key)
Lights up or flashes under the following conditions:
 - Lights in red when the AC power cord is plugged into a wall outlet. Once the projector is in standby mode, you can turn it on with the I/O key.
 - Lights in green when the projector is turned on, and when it is ready to operate.
 - Flashes in green from the projector is turned on until the projector is ready to operate. Also, flashes in green while the cooling fan is running after the power is turned off with the I/O key.

The fan runs for about 60 seconds after the power is turned off.

For details, see page 19.

- 3 INPUT key**
 - 4 MENU key**
Displays the on-screen menu. Press again to clear the menu.
 - 5 ENTER/Δ/▽/◀/▶ (Arrow) keys**
Used to enter the settings of items in the menu system, select a menu, or make various adjustments.
 - 6 FOCUS +/- keys**
Adjusts the picture focus.
 - 7 ZOOM +/- keys**
Adjusts the picture size.
 - 8 PICTURE MUTING key**
Cut off the picture. Press again to restore the picture.
 - 9 Status indicators**
 - **POWER SAVING**
Lights when the projector is in power saving mode.
 - **TEMP (Temperature)/FAN**
Lights or flashes under the following conditions:
 - Lights when the temperature inside the projector becomes unusually high.
 - Flashes when the fan is broken.
 - **LAMP/COVER**
Lights or flashes under the following conditions:
 - Lights when the lamp has reached the end of its life or reaches a high temperature.
 - Flashes when the lamp cover or air filter cover is not secured firmly.
- For details on the TEMP/FAN and LAMP/COVER indicators, see page 41.

Connector Panel

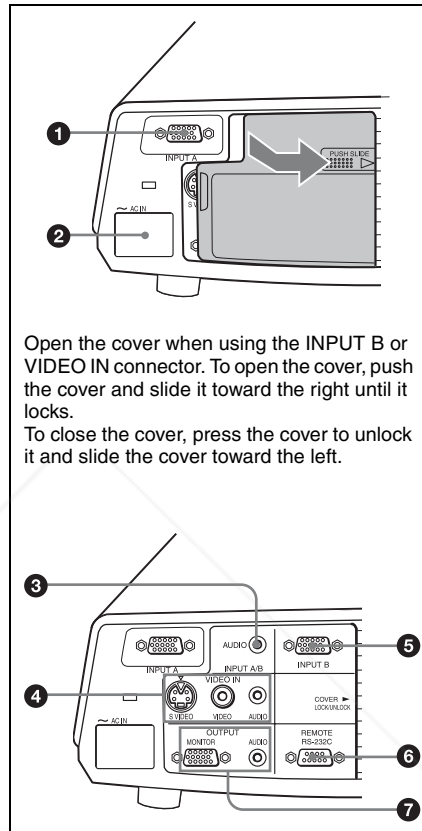

Open the cover when using the INPUT B or VIDEO IN connector. To open the cover, push the cover and slide it toward the right until it locks.

To close the cover, press the cover to unlock it and slide the cover toward the left.

- 1 INPUT A connector (HD D-sub 15-pin, female)**
Inputs a computer signal, video GBR signal, component signal, or DTV signal depending on the connected equipment. Connects to the output connector of equipment using the supplied cable or an optional cable.

For details, see "Connecting a Computer" on page 15 and "Connecting a VCR" on page 16.

- 2 AC IN socket**
Connects the supplied AC power cord.

Overview

3 AUDIO jack (stereo minijack) (common INPUT A/B)

To listen to sound output from a computer, connect via this jack to the audio output of the computer.

4 VIDEO IN (Video input) connector

Connects to external video equipment such as a VCR.

- **S VIDEO (mini DIN 4-pin):** Connects to the S video output (Y/C video output) of video equipment.
- **VIDEO (phono type):** Connects to the composite video output of video equipment.
- **AUDIO (stereo minijack):** Connects to the audio output of the VCR.

5 INPUT B connector (HD D-sub 15-pin, female)

Connect to external equipment such as a computer.

Connects to the monitor output of a computer using an optional cable.

6 RS-232C connector (D-sub 9-pin, female)

Connects to a computer to operate the projector from the computer.

7 OUTPUT connector

- **MONITOR (HD D-sub 15-pin, female):** Connect to the video input connector of the monitor. Outputs signals from the selected channel and computer signals only from among the signals from the INPUT A or INPUT B.
- **AUDIO (stereo minijack):** Connects to external active speakers. The volume of the speakers can be controlled by the VOLUME +/- keys on the Remote Commander.

When INPUT A or B is selected, the sound input to the AUDIO connector which is common for INPUT A/B is output.

When VIDEO or S VIDEO is selected, the sound input to the AUDIO input connector of VIDEO IN is output.

Remote Commander

The keys that have the same names as those on the control panel function identically.

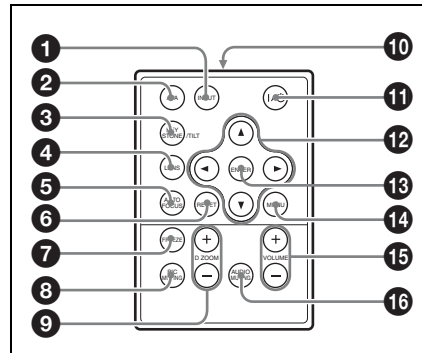

1 INPUT key

2 APA (Auto Pixel Alignment) key

Automatically adjusts a picture to its clearest while a signal is input from a computer.

For details, see "Smart APA" in "The SET SETTING Menu" on page 29.

3 KEYSTONE (Trapezoidal distortion correction)/TILT key

Adjusts the vertical trapezoidal distortion of the image manually. Use the arrow keys (▲/▼/◀/▶) for adjustment.

4 LENS key

Each time you press the key, the adjustment menu is displayed alternately between Lens Focus and Lens Zoom.

5 AUTO FOCUS key

This function is not provided in this projector.

6 RESET key

Resets the value of an item to its factory preset value or returns the enlarged image to its original size. This key functions when the menu or a setting item is displayed on the screen.

7 FREEZE key

Freezes the projected picture. To cancel the frozen picture, press the key again.

8 PIC MUTING key

Cuts off the picture. Press again to restore the picture.

9 D ZOOM (Digital Zoom) +/- key

Enlarges the image at a desired location on the screen.

10 Infrared transmitter

11 I/⏻ (On/Standby) key

12 ▲/▼/◀/▶ (Arrow) keys

13 ENTER key

14 MENU key

15 VOLUME +/- keys

16 AUDIO MUTING key

Press to temporarily cut off the audio output from the speaker. Press again or press the VOLUME + key to restore the sound.

Before using the Remote Commander

Pull out the clear film from the lithium battery holder.

To replace a battery

- 1 Release the lock of the lithium battery holder by picking it, and pull out the holder from the Remote Commander.

- 2 Install the lithium battery.

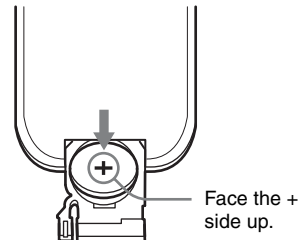

- 3 Put the lithium battery holder back into the Remote Commander.

Notes on the lithium battery

- A button type lithium battery (CR2025) is used in the Remote Commander. Do not use batteries other than CR2025.
- Keep the lithium battery out of the reach of children.
- Should the battery be swallowed, immediately consult a doctor.

Notes on Remote Commander operation

- Make sure that nothing obstructs the infrared beam between the Remote Commander and the remote control detector on the projector. Direct the Remote Commander toward the remote control detector.
- The operation range is limited. The shorter the distance between the Remote Commander and the remote control detector is, the wider the angle within which the commander can control the projector becomes.

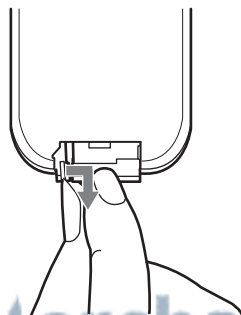

► **Projecting the Picture**

Installing the Projector

The distance between the lens and the screen varies depending on the size of the screen. Use the following table as a guide.

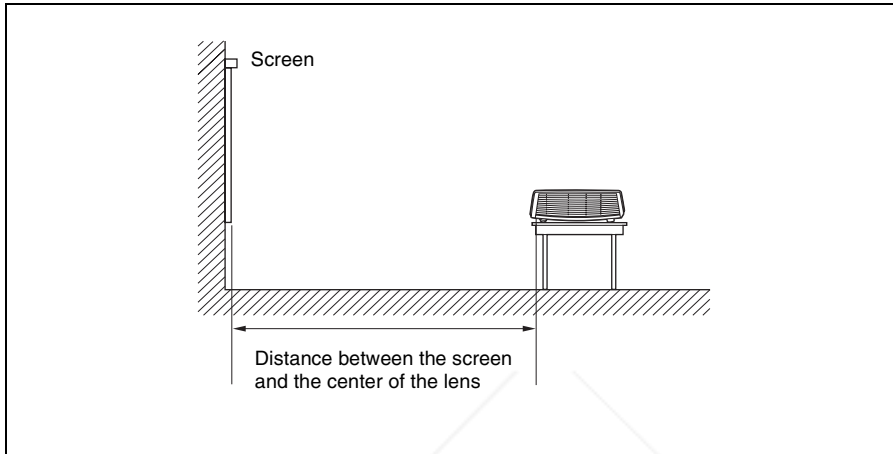

Unit: m (feet)

| Screen size (inches) | 40 | 60 | 80 | 100 | 120 | 150 | 180 | 200 | 250 | 300 |
|-------------------------|--------------|--------------|--------------|---------------|---------------|---------------|---------------|---------------|---------------|----------------|
| Minimum Distance | 1.2 (3.9) | 1.8 (5.9) | 2.4 (7.9) | 3.0 (9.8) | 3.6 (11.8) | 4.5 (14.8) | 5.4 (17.7) | 6.0 (19.7) | 7.5 (24.6) | 9.0 (29.5) |
| Maximum Distance | 1.4 (4.6) | 2.0 (6.6) | 2.7 (8.9) | 3.4 (11.2) | 4.1 (13.5) | 5.2 (17.1) | 6.2 (20.3) | 6.9 (22.6) | 8.7 (28.5) | 10.4 (34.1) |

There may be a slight difference between the actual value and the design value shown in the table above.

For details on installation, see "Installation Diagram" on page 50.

Connecting the Projector

When you connect the projector, make sure to:

- Turn off all equipment before making any connections.
- Use the proper cables for each connection.
- Insert the cable plugs firmly; loose connections may increase noise and reduce performance of picture signals. When pulling out a cable, be sure to pull it out by the plug, not the cable itself.

Connecting a Computer

This section describes how to connect the projector to a computer. For more information, refer to the computer's instruction manual.

To connect a computer

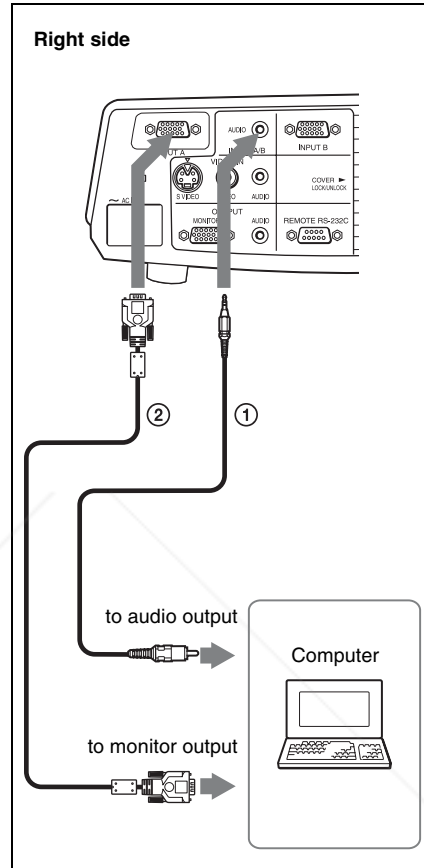

Projecting the Picture

- ① Stereo audio connecting cable (not supplied)
(Use a no-resistance cable.)
- ② HD D-sub 15-pin cable (supplied)

Notes

- The projector accepts VGA, SVGA, XGA, SXGA, and SXGA+ signals. However, we recommend that you set the output mode of your computer to XGA mode for the external monitor.
- If you set your computer, such as a notebook computer, to output the signal to both your computer's display and the external monitor, the picture of the external monitor may not appear properly. Set your computer to output the signal to only the external monitor.

For details, refer to the operating instructions supplied with your computer.

Note

To connect a Macintosh computer equipped with a video output connector of a type having two rows of pins, use a commercially available plug adaptor.

Connecting a VCR

This section describes how to connect the projector to a VCR. For more information, refer to the instruction manuals of the equipment you are connecting.

To connect to a video or S video output connector

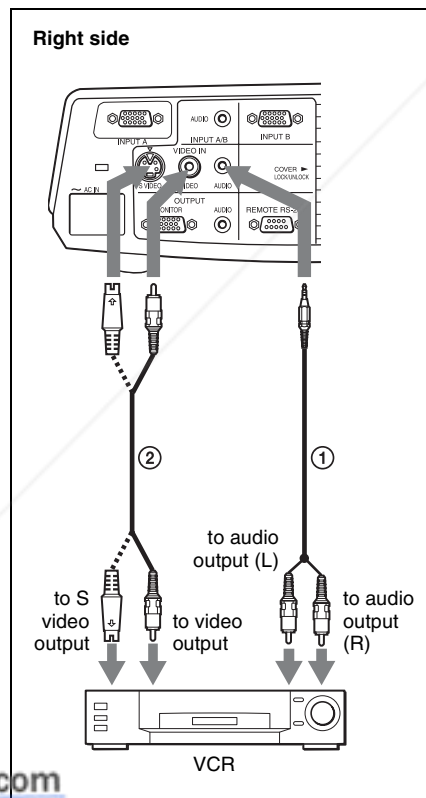

- ① Stereo audio connecting cable (not supplied) (Use a no-resistance cable.)

- ② Video cable (not supplied) or S-Video cable (not supplied)

To connect to a video GBR/Component output connector

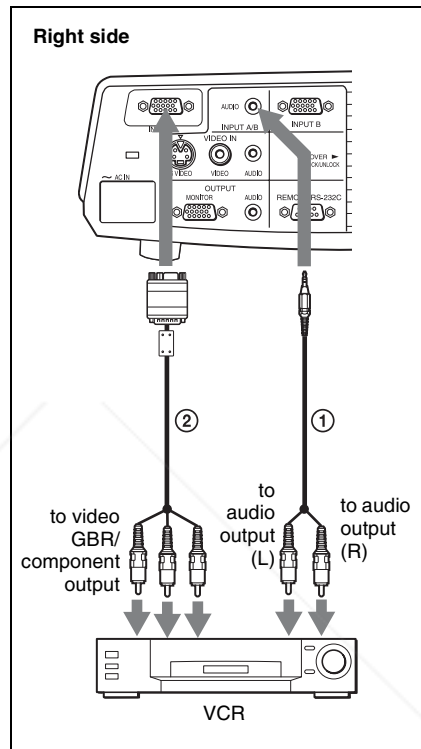

- ① Stereo audio connecting cable (not supplied) (Use a no-resistance cable.)
- ② Signal Cable (not supplied) HD D-sub 15-pin (male) ↔ 3 × phono jack

Notes

- Set the aspect ratio using “Wide Mode” on the INPUT SETTING menu according to the input signal.
- When you connect the projector to a video GBR output connector, select “Video GBR” or when you connect the projector to a component output connector, select “Component” with the “Input-A Signal Sel.” setting on the SET SETTING menu.
- Use the composite sync signal when you input the external sync signal from video GBR/component equipment.

Projecting

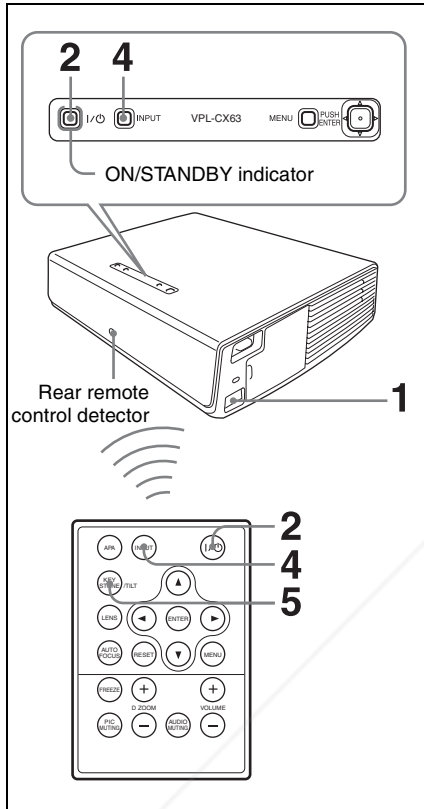

- 1** Plug the AC power cord into a wall outlet, then connect all equipment. The ON/STANDBY indicator lights in red and the projector goes into standby mode.
- 2** Press the I/O key. The ON/STANDBY indicator flashes in green.
- 3** Turn on the equipment connected to the projector.
- 4** Press the INPUT key to select the input source.

Each time you press the key, the input signal switches as follows:

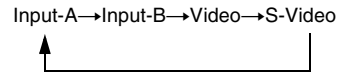

| To input from | Press INPUT to display |
|--|------------------------|
| Computer connected to the INPUT A connector | Input-A |
| Computer connected to the INPUT B connector | Input-B |
| Video equipment connected to the VIDEO input connector | Video |
| Video equipment connected to the S VIDEO input connector | S-Video |

Smart APA (Auto Pixel Alignment) adjusts the picture of the connected equipment so that it is projected clearly.

Notes

- If "Auto Input Search" is set to "On," the projector searches for the signals from the connected equipment and displays the input channel where the input signals are found.
For details, see "Auto Input Search" on page 29.
- The Smart APA feature is effective for the input signal from a computer only.

- 5** Switch the equipment connected to output to the projector. Depending on the type of your computer, for example a notebook, or an all-in-one LCD type, you may have to switch the computer to output to the projector by pressing certain keys (e.g., LCD/VGA, , etc.), or by changing your computer's settings.

Projecting the Picture

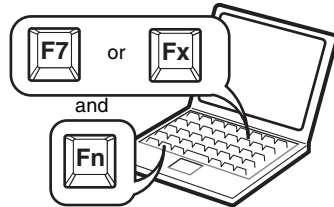

Note

The key used for switching the computer to output to the projector varies depending on the type of computer.

6 Adjust the upper or lower position of the picture.

Use the adjuster to adjust the picture position.

Using the adjuster

Lift the projector while pressing the adjuster adjustment button, and adjust the tilt of the projector, then release the button at the locked position.

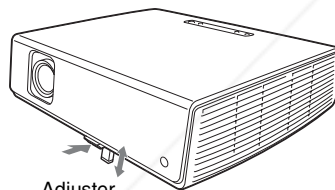

Adjuster adjustment button

Notes

- When you adjust the tilt of the projector with the adjuster, the V keystone adjustment is performed at the same time. If you do not want to perform the automatic keystone adjustment, set the V Keystone menu to "Manual." (See page 32.)

If you set the "V Keystone" adjustment to "Auto," the "V Keystone" correction is automatically adjusted. However, it may not be perfectly adjusted depending on the room temperature or the screen angle. In this case, adjust it manually. Press the KEYSTONE/TILT key on the Remote Commander to "V Keystone"

displays on the screen, and adjust the value with the ▲/▼/◀/▶ keys. The corrected value is effective until the power is turned off.

- Be careful not to let the projector down on your fingers.
- Do not push hard on the top of the projector with the adjuster extended. It may cause a malfunction.

7 Adjust the size of the picture and the focus.

To adjust using the Remote Commander

Select the item to be adjusted by pressing the LENS key, then adjust with the ▲/▼/◀/▶ key. Each time you press the key, the menu toggles between Lens Focus and Lens Zoom in order.

To adjust using the control panel

Press the ZOOM +/- keys on the projector to adjust the size of the picture and press the FOCUS +/- keys to adjust the focus.

Turning Off the Power

- 1 Press the I/⏻ key.
“POWER OFF? Please press I/⏻ key again.” appears to confirm that you want to turn off the power.

Note

The message disappears if you press any key other than the I/⏻ key, or if you do not press any key for five seconds.

- 2 Press the I/⏻ key again.
The ON/STANDBY indicator flashes in green and the fan continues to run for about 60 seconds to reduce the internal heat. Also, the ON/STANDBY indicator flashes quickly for the first 45 seconds. During this time, you will not be able to light up the ON/STANDBY indicator again with the I/⏻ key.
- 3 Unplug the AC power cord from the wall outlet after the fan stops running and the ON/STANDBY indicator lights in red.

When you cannot confirm the on-screen message

When you cannot confirm the on-screen message under certain conditions, you can turn off the power by holding the I/⏻ key for about two seconds instead of following steps 1 and 2.

Note

The internal circuitry of the Off & Go and Direct Power On/Off functions may cause the fan to continue to operate for a short time even after the I/⏻ key is pressed to turn off the power and the ON/STANDBY indicator changes to red.

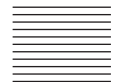

► **Convenient Functions**

Selecting the Menu Language

You can select one of fifteen languages for displaying the menu and other on-screen displays. The factory setting is English. To change the menu language, proceed as follows:

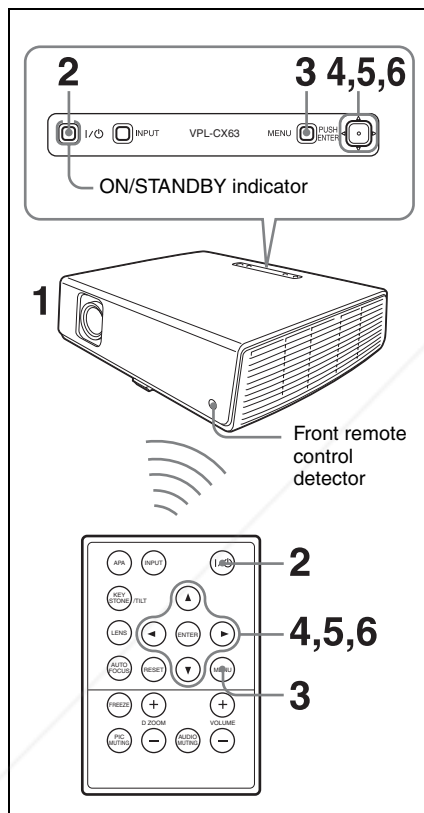

- 1** Plug the AC power cord into a wall outlet.
- 2** Press the I/O key to turn on the projector.
- 3** Press the MENU key. The menu appears. The menu currently selected is shown as a yellow button.

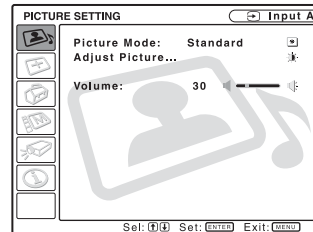

- 4** Press the ▲ or ▼ key to select the MENU SETTING menu, then press the ► or ENTER key. The selected menu appears.

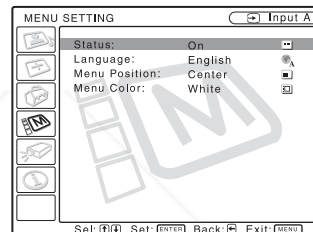

- 5** Press the ▲ or ▼ key to select "Language," then press the ► or ENTER key.

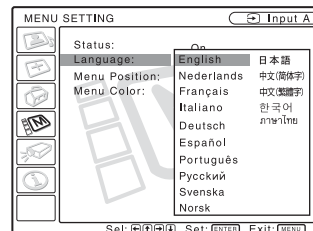

- 6** Press the ▲, ▼, ◀ or ▶ key to select a language, then press the ENTER key. The menu changes to the selected language.

To clear the menu

Press the MENU key. The menu disappears automatically if a key is not pressed for one minute.

Security Lock

The projector is equipped with a security lock function. When you turn the power of the projector on, you are required to input the previously set password. If you do not input the correct password, you will not be able to project the picture.

Note

You will not be able to use the projector if you forget your password and the password administrator is not available. Be please aware that using the security lock can prevent valid usage in such cases.

To use the security lock

- 1 Press the MENU key and then, on the INSTALL SETTING menu, turn on the "Security Lock" setting.
- 2 Enter the password.
Use the MENU, ▲/▼/◀/▶, and ENTER keys to enter the four-digit password. (The default initial password setting is "ENTER, ENTER, ENTER, ENTER." After this is entered you can put in your own password. Therefore, when you use this function for the first time, please input "ENTER" four times.)

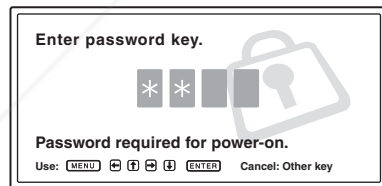

Next, the screen for entering the new password is displayed. (Enter the password on this screen even if you want to keep the current password.) Enter the password on this screen.

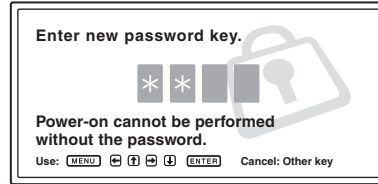

- 3 Enter the password again to confirm.



When the following message is displayed, the setting for security lock is completed.

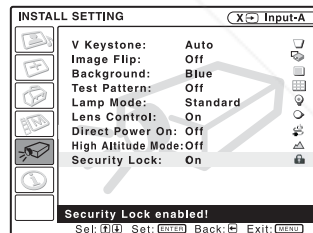

If "Invalid Password!" is displayed on the menu screen, perform this procedure again from step 1.

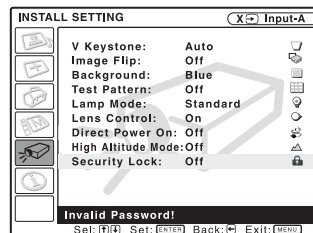

- 4 Turn the main power off and disconnect the AC power cord.

Convenient Functions

The security lock is set to on, then it becomes effective. The screen used for entering the password is displayed when the power is turned on the next time.

Security certification

When the password screen is displayed, enter the password that was set. If you fail to enter the correct password after three tries, the projector cannot be used. In this case, press the I/⏻ key to turn off the power.

To cancel the security lock

- 1 Press the MENU key, then turn off the “Security Lock” setting on the INSTALL SETTING menu.
- 2 Enter the password.
Enter the password that was set.

Note

If you call the customer service center because you have forgotten the password, you will need to be able to verify the projector’s serial number and your identity. (This process may differ in other countries/regions.) Once your identity has been confirmed, we will provide you with the password.

Other Functions

Switching from Auto Adjustments Function to Manual Adjustments

You can switch the following auto adjustments functions to manual adjustments using the menu.

- **V Keystone correction (correction of trapezoidal distortion)**
Set “V Keystone” in the INSTALL SETTING menu to “Manual.”
- **Smart APA (Auto Pixel Alignment)**
Set “Smart APA” in the SET SETTING menu to “Off.”
- **Auto Input Search**
Set “Auto Input Search” in the SET SETTING menu to “Off.”

For details on the menu operations, see “Using a MENU” on page 24.

Off & Go Function

The cooling fan runs for a certain time automatically even after the power is turned off and the power cord is disconnected. This enables you to move the projector from the conference room to another location immediately after turning it off.

Direct Power On/Off Function

If you will be using a circuit breaker to turn the power for the entire system on and off, set the direct power on function to “On.” When you turn off the power, you can also just unplug the power cord without pressing the I/⏻ key. The internal circuitry will cause the fan to automatically operate for a certain time even after the power cord is removed.

Note

However, if the unit has been on for less than 15 minutes, the fan might not begin to turn as a result of inadequate charging. In that case, follow the procedure for turning off the power as described in “Turning Off the Power” on page 19.

Effective Tools for Your Presentation

To enlarge the image (Digital Zoom function)

You can select a section of the image to enlarge. This function works when a signal from a computer is input. This function does not work when a video signal is input.

- 1 Project a normal image, and press the D ZOOM + key on the Remote Commander.
The digital zoom icon appears in the center of the image.

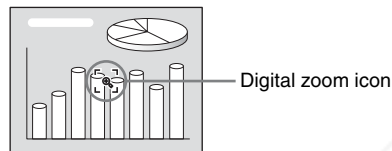

- 2 Move the icon to the point on the image you want to enlarge. Use the arrow key (▲/▼/◀/▶) to move the icon.
- 3 Press the D ZOOM + key again.
The portion of the image where the icon is located is enlarged. The enlargement ratio is displayed on the screen for a few seconds.
By pressing the + key repeatedly, the image size (ratio of enlargement: max. 4 times) increases.

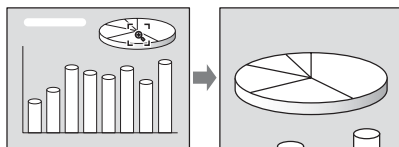

Use the arrow key (▲/▼/◀/▶) to scroll the enlarged image.

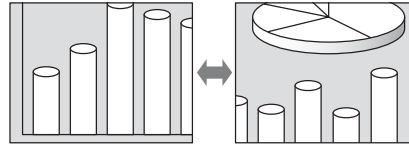

To return the image to its original size

Press the D ZOOM – key.
Just pressing the RESET key returns the image back to its original size immediately.

To freeze the image projected (Freeze function)

Press the FREEZE key. “Freeze” appears when the key is pressed. This function works when a signal from a computer is input. To restore the original screen, press the FREEZE key again.

Convenient Functions

► **Adjustments and Settings Using a Menu**

Using a MENU

The projector is equipped with an on-screen menu for making various adjustments and settings.

Display items

Input signal indicator

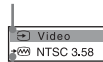

Input signal setting indicator

Picture adjustment menu

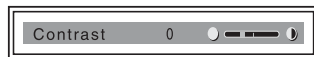

Input signal indicator

Shows the selected input channel. X(→) is displayed when no signal is input. You can hide this indicator using “Status” on the MENU SETTING menu.

Input signal setting indicator

For Input-A: Shows “Computer,” “Component,” or “Video GBR.”
For Video/S-Video input: Shows “Auto” or the “Color System” setting on the SET SETTING menu.

- 1 Press the MENU key.
The menu appears.
The menu presently selected is shown as a yellow button in the column on the left.

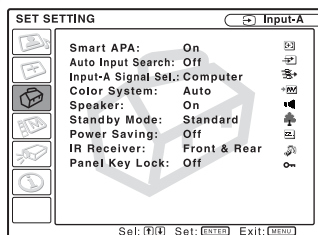

- 2 Use the ▲ or ▼ key to select a menu, then press the ► or ENTER key.
The selected menu appears.

- 3 Select an item.
Use the ▲ or ▼ key to select the item, then press the ► or ENTER key.
The setting items are displayed in a pop-up menu or in a sub menu.

Pop-up menu

Menu Setting items Selected input signal

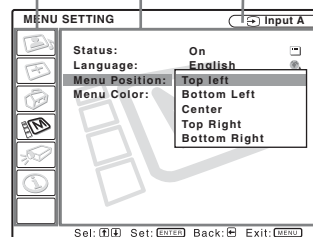

Sub menu

Menu Setting items

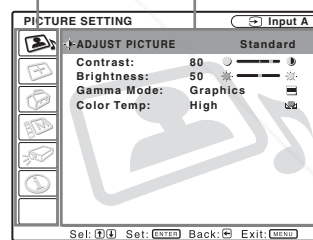

- 4 Make the setting or adjustment of an item.
 - **When changing the adjustment level:**
To increase the number, press the ▲ or ► key.
To decrease the number, press the ▼ or ◀ key.
Press the ENTER key to restore the previous screen.
 - **When changing the setting:**
Press the ▲ or ▼ key to change the setting.
Press the ENTER or ◀ key to restore the previous screen.

To clear the menu

Press the MENU key.
The menu disappears automatically if a key is not pressed for one minute.

To reset items that have been adjusted

Select the item that you want to reset, and then press the RESET key on the Remote Commander.
“Complete!” appears on the screen and **the setting of the item that you have selected is reset to its factory preset value.**

Items that can be reset are:

- “Contrast,” “Brightness,” “Color,” “Hue” and “Sharpness” on the “Adjust Picture...” menu.
- “Dot Phase,” “H Size,” and “Shift” on the “Adjust Signal...” menu

Storage of the settings

The settings are automatically stored in the projector memory when the ENTER key is pressed.

If no signal is input

If there is no input signal, “Cannot adjust this item.” appears on the screen.

Unadjustable items

Items that cannot be adjusted, depending on the input signal, are not displayed on the menu.

For details, see page 35.

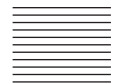

The PICTURE SETTING Menu

The PICTURE SETTING menu is used for adjusting the picture or volume. Items that can be adjusted or set depend on the kind of input signals. For details, see “Input signals and adjustable/setting items” on page 35.

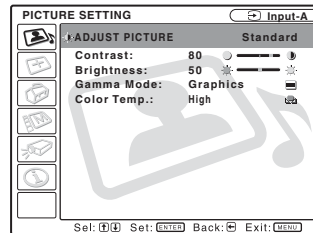
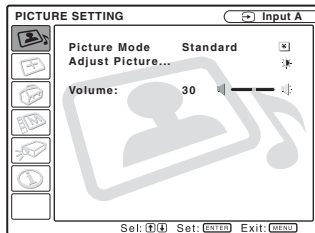

| Setting items | Functions | Initial setting |
|-------------------|---|-----------------------------|
| Picture Mode | Selects the picture mode. <ul style="list-style-type: none"> • Dynamic: Emphasizes the contrast to produce a “dynamic” picture. • Standard: Normally select this setting. If the picture has roughness with the “Dynamic” setting, this setting reduces the roughness. | Standard |
| Adjust Picture... | The unit can store the setting values of the following sub menu items for each “Dynamic” or “Standard” picture mode separately. | |
| Contrast | Adjusts the picture contrast. | 80 |
| Brightness | Adjusts the picture brightness. | 50 |
| Color | Adjusts color intensity. | 50 |
| Hue | Adjusts color tones. The higher the setting, the more greenish the picture becomes. The lower the setting, the more purplish. | 50 |
| Sharpness | Selects the picture sharpness from among “High,” “Middle,” and “Low.” The “High” setting makes the picture sharp; the “Low” setting makes it soft. | High |
| Gamma Mode | Selects a gamma correction curve. <ul style="list-style-type: none"> • Graphics: Improves the reproduction of halftones. Photos can be reproduced in natural tones. • Text: Contrasts black and white. Suitable for images that contain lots of text. | Graphics |
| Color Temp. | Adjusts the color temperature. <ul style="list-style-type: none"> • High: Makes white colors bluish. • Low: Makes white colors reddish. | High Low (Video/S-Video) |
| Volume | Adjusts the volume. | 30 |

The INPUT SETTING Menu

The INPUT SETTING menu is used to adjust the input signal. Items that can be adjusted or set depend on the kind of input signals. For details, see “Input signals and adjustable/setting items” on page 35.

When the video signal is input

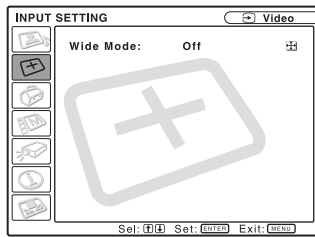

| Setting items | Functions | Initial setting |
|---------------|--|-----------------|
| Wide Mode | Sets the aspect ratio of the picture. <ul style="list-style-type: none"> • Off: When a picture with a ratio of 4:3 is input. • On: When a picture with a ratio of 16:9 (squeezed) is input from a DVD player. | Off |

When the signal is input from a computer

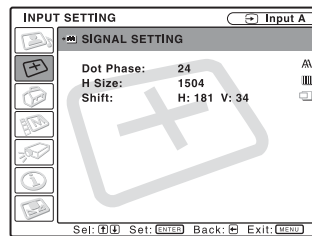
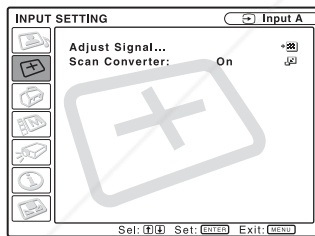

| Setting items | Functions | Initial setting |
|------------------|--|-----------------------------------|
| Adjust Signal... | | |
| Dot Phase | Adjusts the dot phase of the LCD panel and the signal output from a computer. Adjust the picture further for finer picture after the picture is adjusted by pressing the APA key. | Set according to the input signal |
| H Size | Adjusts the horizontal size of a picture output from a computer. Adjust the setting according to the dots of the input signal. For details, see page 47. | Set according to the input signal |

| Setting items | Functions | Initial setting |
|----------------|---|-----------------------------------|
| Shift | Adjusts the position of the picture. H adjusts the horizontal position of the picture. V adjusts the vertical position of the picture. As the setting for H increases, the picture moves to the right, and as the setting decreases, the picture moves to the left. As the setting for V increases, the picture moves up, and as the setting decreases, the picture moves down. Use the ◀ or the ▶ key to adjust the horizontal position and the ▲ and ▼ key for the vertical position. | Set according to the input signal |
| Scan Converter | Converts the signal to display the picture according to the screen size. When set to "Off," displays the picture while matching one pixel of input picture element to that of the LCD. The picture will be clear but the picture size will be smaller. | On |

Note

Note that if the projector is used for profit or for public viewing, modifying the original picture by switching to the wide mode may constitute an infringement of the rights of authors or producers, which are legally protected.

About the Preset Memory No.

This projector has 45 types of preset data for input signals (the preset memory). When a preset signal is input, the projector automatically detects the signal type and recalls the data for the signal from the preset memory to adjust it to an optimum picture. The memory number and signal type of that signal are displayed on the INFORMATION menu (See page 34). You can also adjust the preset data through the INPUT SETTING menu.

This projector has 20 types of user memories for Input-A into which you can save the setting of the adjusted data for an unpreset input signal.

When an unpreset signal is input for the first time, a memory number is displayed as 0. When you adjust the data of the signal using the INPUT SETTING menu, it will be registered in the projector. If more than 20 user memory items are registered, the newest memory always overwrites the oldest one.

See the chart on page 47 to find if the signal is registered in the preset memory.

Since the data for the following signals is recalled from the preset memory, you can

use these preset data items by adjusting "H Size." Make finer adjustments by adjusting "Shift."

| Signal | Memory No. | SIZE |
|------------------------|------------|------|
| Super Mac-2 | 23 | 1312 |
| SGI-1 | 23 | 1320 |
| Macintosh 19" | 25 | 1328 |
| Macintosh 21" | 27 | 1456 |
| Sony News | 36 | 1708 |
| PC-9821 1280 × 1024 | 36 | 1600 |
| WS Sunmicro | 37 | 1664 |

Note

When the aspect ratio of input signal is other than 4:3, a part of the screen is displayed in black.



Discount-Merchant.com (800) 281-8860

THE TRUSTED SOURCE FOR PROJECTOR LAMPS AND ACCESSORIES

The SET SETTING Menu

The SET SETTING menu is used for changing the settings of the projector.

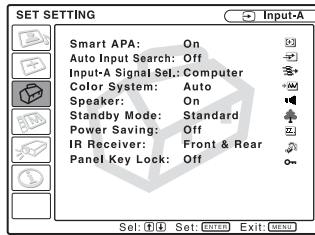

| Setting items | Functions | Initial setting |
|---------------------|---|-----------------|
| Smart APA | The APA (Auto Pixel Alignment) automatically adjusts "Dot Phase," "H Size" and "Shift" on the INPUT SETTING menu for the input signal from a computer. <ul style="list-style-type: none"> • On: When a signal is input from a computer, the APA functions automatically so that the picture can be seen clearly. Once the specified input signal has been adjusted by the "Smart APA," it will not be readjusted even when the cable is disconnected and connected again or the input channel is changed. You can adjust the picture by pressing the APA key on the Remote Commander even if "Smart APA" set to "On." • Off: The APA functions when you press the APA key on the Remote Commander. | On |
| Auto Input Search | When set to "On," the projector detects input signals in the following order: Input-A/Input-B/Video/S-Video. It indicates the input channel when the power is turned on or the INPUT key is pressed. | Off |
| Input-A Signal Sel. | Selects the "Computer," "Component," or "Video GBR" signal input via the INPUT A connector. | Computer |
| Color System | Selects the color system of the input signal. If you select "Auto," the projector detects the color system of the input signal automatically. If the picture is distorted or colorless, select the color system according to the input signal. When the color system of the input signal is PAL60, select "PAL." If "Auto" is selected, the color system cannot be detected. | Auto |
| Speaker | Set to "Off" to cut off the sound of the internal speakers. When set to "Off," "Speaker:Off" appears on the screen when you turn on the power. | On |

Adjustments and Settings Using a Menu

| Setting items | Functions | Initial setting |
|----------------|---|-----------------|
| Standby Mode | You can lower the power consumption in standby mode. <ul style="list-style-type: none"> • Standard: Normally, select this position. • Low: Select this position when you want to lower the power consumption in standby mode. | Standard |
| Power Saving | When set to "On," the projector goes into power saving mode if no signal is input for 10 minutes. Although the lamp goes out, the cooling fan keeps running. The power saving mode is canceled when a signal is input or any key is pressed. In power saving mode, no keys function for the first 45 seconds after the lamp goes out. | Off |
| IR Receiver | Selects the remote control detectors (IR Receiver) on the front and rear of the projector. <ul style="list-style-type: none"> • Front & Rear: Activates both the front and rear detectors. • Front: Activates the front detector only. • Rear: Activates the rear detector only. | Front & Rear |
| Panel Key Lock | Locks all the control panel keys on the rear and side panels of the projector so that the projector can be operated only with the Remote Commander. To lock the control panel keys, set to "On." When it is set to "On," keeping the I/⏻ key on the control panel pressed for 10 seconds turns the projector on when it is in standby mode, and turns the projector to standby mode when the power is on. If you press and hold the MENU key for about 10 seconds when the power is on, the lock will be released and "Panel Key Lock" is automatically set to "Off." | Off |

Notes

- Press the APA key when the full image is displayed on the screen. If the projected image includes a black portion around it, the APA function will not work properly and some parts of the image may not be displayed on the screen.
- You can cancel the adjustment by pressing the APA key again while "Adjusting" appears on the screen.
- The picture may not be adjusted properly depending on the type of input signal.
- Adjust the "Dot Phase," "H Size," and "Shift" items on the INPUT SETTING menu when you adjust the picture manually.

The MENU SETTING Menu

The MENU SETTING menu is used for changing the menu displays.

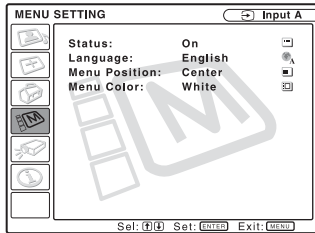

| Setting items | Functions | Initial setting |
|----------------------------|---|-----------------|
| Status (on-screen display) | Sets up the on-screen display. When set to "Off," turns off the on-screen displays except for the menus, a message when the power is turned off, and warning messages. | On |
| Language | Selects the language used in the menu and on-screen displays. The languages available are: English, Nederlands, Français, Italiano, Deutsch, Español, Português, Русский, Svenska, Norsk, 日本語, 中文(简体字), 中文(繁體字), 한국어 and ภาษาไทย. | English |
| Menu Position | Selects the display position of the menu from "Top Left," "Bottom Left," "Center," "Top Right," and "Bottom Right." | Center |
| Menu Color | Selects the tone of the menu display from "Black" or "White." | White |

Adjustments and Settings Using a Menu

The INSTALL SETTING Menu

The INSTALL SETTING menu is used for changing the settings of the projector.

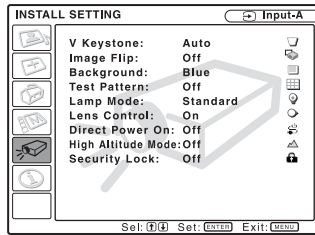

| Setting items | Functions | Initial setting |
|--------------------|--|-----------------|
| V Keystone | Corrects the trapezoidal distortion caused by the projection angle. Select "Auto" for automatic correction, or "Manual" for manual correction using the ▲/▼/◀/▶ keys on the Remote Commander. When the bottom of the trapezoid is longer than the top □ : Sets a lower value. When the top of the trapezoid is longer than the bottom □ : Sets a higher value. | Auto |
| Image Flip | Flips the image on the screen horizontally and/or vertically. • Off: The image does not flip. • HV: Flips the image horizontally and vertically. • H: Flips the image horizontally. • V: Flips the image vertically. | Off |
| Background | Selects the background color of the screen when no signal is input to the projector. Select "Black" or "Blue." Normally, set to "Blue." | Blue |
| Test Pattern | When set to "On," a test pattern is displayed on the screen during "Lens Zoom" adjustment, "Lens Focus," or "V Keystone." | Off |
| Lamp Mode | Sets the lamp brightness used during the projection. • High: Illuminates the projected image brightly. • Standard: Reduces fan noise and power consumption. The brightness of the projected image will be lower compared with the "High" setting. | Standard |
| Lens Control | When set to "Off," the LENS (FOCUS, ZOOM) key on the Remote Commander, and the FOCUS and ZOOM keys on the projector do not function. | On |
| Direct Power On | Set to "On" if you are using a circuit breaker to turn the power on/off the entire system. You can turn off the power just by unplugging the power cord without pressing the I/O key. | Off |
| High Altitude Mode | Set to "On" when the projector is used at an altitude of 1,500 m or higher. | Off |

| Setting items | Functions | Initial setting |
|---------------|--|-----------------|
| Security Lock | Turns on the projector's security lock function. When set to "On," turns on the security lock function, which locks the projector once a password has been set. <i>For details, see "Security Lock" on page 21.</i> | Off |

Note

The auto V Keystone adjustment may not correct the trapezoidal distortion perfectly, depending on the room temperature or the screen angle.

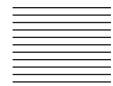

The INFORMATION Menu

The INFORMATION menu displays the model name, serial number, the horizontal and vertical frequencies of the input signal and the cumulated hours of usage of the lamp.

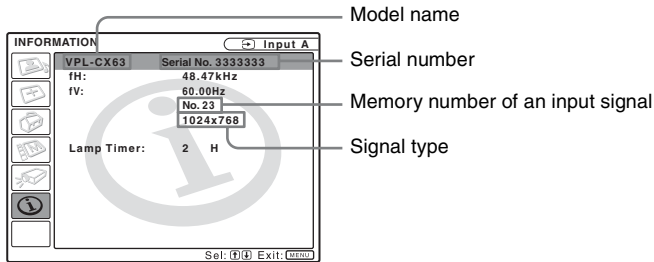

| Setting items | Functions |
|---------------|--|
| fH | Displays the horizontal frequency of the input signal. The displayed value is approximate. |
| fV | Displays the vertical frequency of the input signal. The displayed value is approximate. |
| Lamp Timer | Indicates how long the lamp has been turned on. |

Note

These are only displayed on the screen. You cannot alter the display, and there is no setting to be altered.

Input signals and adjustable/setting items

Adjust Picture... menu

| Item | Input signal | | | | |
|-------------------|----------------------------|-----------|-----------|----------|-----|
| | Video or S-Video (Y/C) | Component | Video GBR | Computer | B&W |
| Picture Mode | ● | ● | ● | ● | ● |
| Adjust Picture... | | | | | |
| Contrast | ● | ● | ● | ● | ● |
| Brightness | ● | ● | ● | ● | ● |
| Color | ● | ● | ● | — | — |
| Hue | ● (NTSC 3.58/4.43 only) | ● | ● | — | — |
| Sharpness | ● | ● | ● | — | ● |
| Gamma Mode | — | — | ●*1 | ● | — |
| Color Temp. | ● | ● | ● | ● | ● |
| Volume | ● | ● | ● | ● | ● |

● : Adjustable/can be set

— : Not adjustable/cannot be set

*1: Preset memory No. 3, 4 only

INPUT SETTING menu

| Item | Input signal | | | | |
|------------------|------------------------|-----------|-----------|------------------------|-----|
| | Video or S-Video (Y/C) | Component | Video GBR | Computer | B&W |
| Adjust Signal... | | | | | |
| Dot Phase | — | — | — | ● | — |
| H Size | — | ●*1 | ●*1 | ● | — |
| Shift | — | ●*1 | ●*1 | ● | — |
| Scan Converter | — | — | — | ● (lower than SVGA) | — |
| Wide Mode | ● | ●*2 | ●*2 | — | ● |

● : Adjustable/can be set

— : Not adjustable/cannot be set

*1: Expect preset memory No. 3, 4

*2: Expect preset memory No. 5, 45, 47, 48, 50



Adjustments and Settings Using a Menu

► **Maintenance**

Replacing the Lamp

The lamp used as a light source is a consumable product. Thus replace this lamp with a new one in the following cases.

- When the lamp has burnt out or dims
- “Please replace the Lamp.” appears on the screen
- The LAMP/COVER indicator lights up

The lamp life varies depending on conditions of use.

Use an LMP-C190 Projector Lamp as the replacement lamp.

Use of any other lamps than the LMP-C190 may cause damage to the projector.

Caution

The lamp remains hot after the projector is turned off with the I/⏻ key. **If you touch the lamp, you may burn your finger. When you replace the lamp, wait for at least an hour for the lamp to cool.**

Notes

- **If the lamp breaks, consult with qualified for personal.**
- Pull out the lamp by holding the handle. If you touch the lamp, you may be burned or injured.
- When removing the lamp, make sure it remains horizontal, then pull straight up. Do not tilt the lamp. If you pull out the lamp while it is tilted and if the lamp breaks, the pieces may scatter, causing injury.
- To erase a message, press any key on the control panel of the projector or on the remote commander.

- 1** Turn off the projector, and disconnect the AC power cord from the AC outlet.

Note

When replacing the lamp after using the projector, wait for at least an hour for the lamp to cool.

- 2** Place a protective sheet (cloth) beneath the projector. Turn the

projector over so you can see its underside.

Note

Be sure that the projector is stable after turning it over.

- 3** Open the lamp cover by loosening the screw with a Phillips screwdriver.

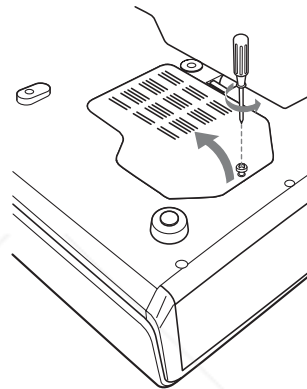

Note

For safety reasons, do not loosen any other screws.

- 4** Loosen the two screws on the lamp unit with the Phillips screwdriver (1). Fold out the handle (2), then pull out the lamp unit by the handle (3).

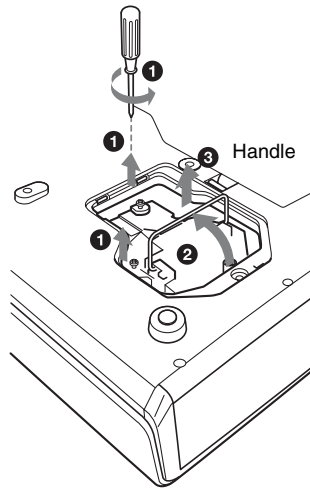

- 5** Insert the new lamp all the way in until it is securely in place (1). Tighten the two screws (2). Fold down the handle to replace it (3).

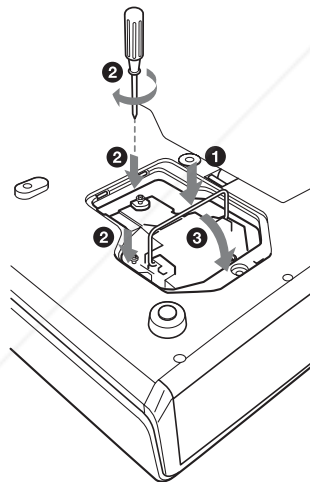

Notes

- Be careful not to touch the glass surface of the lamp.
- The power will not turn on if the lamp is not secured properly.

- 6** Close the lamp cover and tighten the screw.

Note

Be sure to attach the lamp cover securely as it was. If not, the projector cannot be turned on.

- 7** Turn the projector back over.

- 8** Connect the power cord.
The ON/STANDBY indicator around the I/O key lights in red.

- 9** Press the following keys on the Remote Commander in the following order for less than five seconds each: RESET, ◀, ▶, ENTER.

Caution

Do not put your hands into the lamp replacement slot, and do not allow any liquid or other objects into the slot **to avoid electrical shock or fire.**

**Disposal of the used lamp
For the customers in the USA**

This product contains mercury. Disposal of this product may be regulated if sold in the United States. For disposal or recycling information, please contact your local authorities or the Electronics Industries Alliance (<http://www.eiae.org>).



Maintenance



Discount-Merchant.com (800) 281-8860
THE TRUSTED SOURCE FOR PROJECTOR LAMPS AND ACCESSORIES

Replacing the Lamp

Cleaning the Air Filter

The air filter should be cleaned every 1000 hours.

Remove dust from the outside of the ventilation holes with a vacuum cleaner. 1000 hours are approximate. This value varies depending on the environment or how the projector is used.

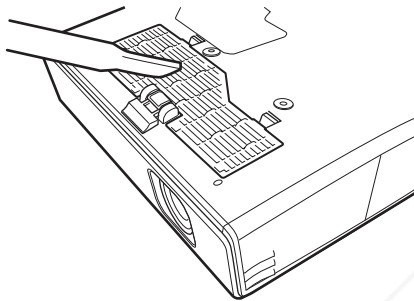

When it becomes difficult to remove the dust from the filter with a vacuum cleaner, remove the air filter and wash it.

- 1 Turn the power off and unplug the power cord.
- 2 Place a protective sheet (cloth) beneath the projector and turn the projector over.
- 3 Remove the air filter cover.

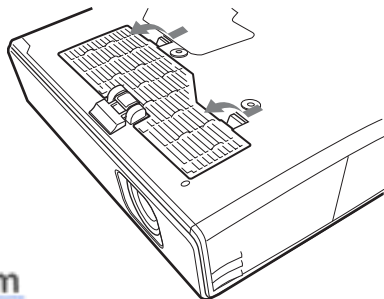

- 4 Remove the air filter.

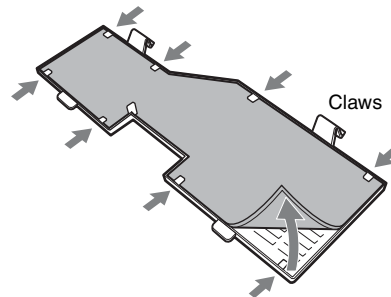

- 5 Wash the air filter with a mild detergent solution and dry it in a shaded place.
- 6 Attach the air filter so that it fits into the each claws (8 positions) on the air filter covers and replace the cover.

Notes

- If you neglect to clean the air filter, dust may accumulate, clogging it. As a result, the temperature may rise inside the unit, leading to a possible malfunction or fire.
- If the dust cannot be removed from the air filter, replace the air filter with the supplied new one.
- Be sure to attach the air filter cover firmly; the power can not be turned on if it is not closed securely.
- The air filter has a face and a reverse side. Place the air filter so that it fits in a notch on the air filter cover.
- To erase a message, press any key on the control panel of the projector or on the remote commander.

► **Others**

Troubleshooting

If the projector appears to be operating erratically, try to diagnose and correct the problem using the following instructions. If the problem persists, consult with qualified Sony personnel.



Power

| Symptom | Cause and Remedy |
|---|---|
| The power is not turned on. | <ul style="list-style-type: none"> • The power has been turned off and on with the  key at a short interval. → Wait for about 60 seconds before turning on the power (see page 19). • The lamp cover is not secured. → Close the lamp cover securely (see page 37). • The air filter cover is detached. → Attach the air filter cover securely (see page 38). |
| Both the LAMP/COVER and TEMP/FAN indicators light up. | <p>The electrical system has broken down. → Consult with qualified Sony personnel.</p> |

Picture

| Symptom | Cause and Remedy |
|--|---|
| No picture. | <ul style="list-style-type: none"> • A cable is disconnected or the connections are wrong. → Check that the proper connections have been made (see page 15). • The connections are wrong. → This projector is compatible with DDC2B (Digital Data Channel 2B). If your computer is compatible with DDC, turn the projector on according to the following procedures. <ol style="list-style-type: none"> 1 Connect the projector to the computer. 2 Turn the projector on. 3 Start the computer. • Input selection is incorrect. → Select the input source correctly using the INPUT key (see page 17). • The picture is muted. → Press the PIC MUTING key to release the picture muting (see page 12). • The computer signal is not set to output to an external monitor or set to output both to an external monitor and a LCD monitor of a computer. → Set the computer signal to output only to an external monitor (see page 15). |
| The picture is noisy. | <p>Noise may appear on the background depending on the combination of the number of dots input from the computer and the numbers of pixels on the LCD panel. → Change the desktop pattern on the connected computer.</p> |
| The picture from the INPUT A connector is colored strangely. | <p>The setting of "Input-A Signal Sel." on the SET SETTING menu is incorrect. → Select "Computer," "Video GBR" or "Component" correctly according to the input signal (see page 29).</p> |

Others

FixYourDLP.com
 Sponsored by  Discount-Merchant.com (800) 281-8860
THE TRUSTED SOURCE FOR PROJECTOR LAMPS AND ACCESSORIES

| Symptom | Cause and Remedy |
|---|--|
| “Please check Input-A Signal Sel.” appears in spite of inputting the correct signal from INPUT A. | The setting of “Input-A Signal Sel.” on the SET SETTING menu is incorrect. → Select “Computer,” “Video GBR” or “Component” correctly according to the input signal (see page 29). |
| On-screen display does not appear. | “Status” on the MENU SETTING menu has been set to “Off.” → Set “Status” on the MENU SETTING menu to “On” (see page 32). |
| Color balance is incorrect. | <ul style="list-style-type: none"> • The picture has not been adjusted properly. → Adjust the picture (see page 26). • The projector is set to the wrong color system. → Set “Color System” on the SET SETTING menu to match the color system being input (see page 29). |
| The picture is too dark. | <ul style="list-style-type: none"> • Contrast or brightness has not been adjusted properly. → Adjust the contrast or brightness on the “Adjust Picture...” menu properly (see page 26). • The lamp has burnt out or is dim. → Replace the lamp with a new one (see page 36). |
| The picture is not clear. | <ul style="list-style-type: none"> • The picture is out of focus. → Adjust the focus (see page 18). • Condensation has accumulated on the lens. → Leave the projector for about two hours with the power on. |
| The image extends beyond the screen. | The APA key has been pressed even though there are black edges around the image. → Display the full image on the screen and press the APA key. → Adjust “Shift” on the INPUT SETTING menu properly (see page 28). |
| The picture flickers. | “Dot Phase” on the INPUT SETTING menu has not been adjusted properly. → Adjust “Dot Phase” on the INPUT SETTING menu properly (see page 27). |

Sound

| Symptom | Cause and Remedy |
|-----------|--|
| No sound. | <ul style="list-style-type: none"> • A cable is disconnected or the connections are wrong. → Check that the proper connections have been made (see page 15). • The audio connecting cable used is incorrect. → Use a no-resistance stereo audio cable (see page 15). • The sound is muted. → Press the AUDIO MUTING key to release audio muting (see page 13). • The sound is not adjusted properly. → Adjust the sound with the VOLUME +/- key on the Remote Commander or adjust "Volume" on the PICTURE SETTING menu (see page 26). • "Speaker" is set to "Off." → Set "Speaker" in the SET SETTING menu to "On" (see page 29). |

Remote Commander/Presentation tool

| Symptom | Cause and Remedy |
|-------------------------------------|---|
| The Remote Commander does not work. | <ul style="list-style-type: none"> • The Remote Commander batteries are dead. → Replace them with new batteries (see page 13). |

Others

| Symptom | Cause and Remedy |
|---|---|
| The control panel keys do not function. | <ul style="list-style-type: none"> • The control panel keys are locked. → Unlock the control panel keys (see page 30). |

Indicators

| Symptom | Cause and Remedy |
|-------------------------------------|--|
| The LAMP/COVER indicator flashes. | <ul style="list-style-type: none"> • The lamp cover or the air filter cover is detached. → Attach the cover securely (see pages 37 and 38). • The electrical system may have broken down. → Consult with qualified Sony personnel. |
| The LAMP/COVER indicator lights up. | <ul style="list-style-type: none"> • The lamp has reached the end of its life. → Replace the lamp (see page 36). • The lamp has reached a high temperature. → Wait for 60 seconds to cool the lamp and then turn on the power again. • If the LAMP/COVER indicator still lights even after you have replaced the lamp, the electrical system may break down. → Consult with qualified Sony personnel. |
| The TEMP/FAN indicator flashes. | <ul style="list-style-type: none"> • The fan is broken. → Consult with qualified Sony personnel. |



Others

| Symptom | Cause and Remedy |
|---|--|
| The TEMP/FAN indicator lights up. | <ul style="list-style-type: none"> • The internal temperature is unusually high. <ul style="list-style-type: none"> → Check to see that nothing is blocking the ventilation holes. • The projector is being used at a high altitude. <ul style="list-style-type: none"> → Ensure that “High Altitude Mode” on the INSTALL SETTING menu is set to “On.” |
| Both the LAMP/COVER and TEMP/FAN indicators light up. | <p>The electrical system has broken down.</p> <ul style="list-style-type: none"> → Consult with qualified Sony personnel. |

Messages List

Warning Messages

Use the list below to check the meaning of the messages displayed on the screen.

| Message | Meaning and Remedy |
|--|--|
| High temp.! Probably use in high altitude. Switch to high altitude mode on? Yes ↑ No ↓ | <p>Internal temperature is too high.</p> <ul style="list-style-type: none"> → When using the projector at an altitude of 1,500 m or higher, set “High Altitude Mode” on the INSTALL SETTING menu to “On” (see page 32). → If this message appears on the screen when using the projector at normal altitudes, check to see if anything is blocking the ventilation holes (exhaust). |
| High temp.! Lamp off in 1 min. | <p>The internal temperature is too high.</p> <ul style="list-style-type: none"> → Turn off the power. → Check to see that nothing is blocking the ventilation holes. |
| Frequency is out of range! | <ul style="list-style-type: none"> • This input signal cannot be projected as the frequency is out of the acceptable range of the projector. <ul style="list-style-type: none"> → Input a signal that is within the range of the frequency. • The resolution setting of the output signal of the computer is too high. <ul style="list-style-type: none"> → Set the output setting to XGA (see page 15). |
| Please check Input-A Signal Sel. | <p>You have input an RGB signal from the computer when “Input-A Signal Sel.” on the SET SETTING menu is set to “Component.”</p> <ul style="list-style-type: none"> → Set “Input-A Signal Sel.” correctly (see page 29). |
| Please replace the Lamp. | <ul style="list-style-type: none"> • It is time to replace the lamp. <ul style="list-style-type: none"> → Replace the lamp (see page 36). → To erase a message, press any key on the control panel of the projector or on the remote commander. • If this message appears again after you replace the lamp, the lamp replacement process is not complete. <ul style="list-style-type: none"> → Perform the operations in step 8 and 9 on page 37. |
| Please clean the filter. | <ul style="list-style-type: none"> • It is time to clean the filter. <ul style="list-style-type: none"> → Clean the filter (see page 38). → To erase a message, press any key on the control panel of the projector or on the remote commander. |

Caution Messages

Use the list below to check the meaning of the messages displayed on the screen.

| Message | Meaning and Remedy |
|----------------------------|--|
| Not applicable! | You have pressed the wrong key. → Press the appropriate key. |
| The panel keys are locked! | “Panel Key Lock” on the SET SETTING menu is set to “On.” → All the keys on the control panel of the projector are locked. Operate the projector with the keys on the Remote Commander (see page 30). |



Specifications

Optical characteristics

| | |
|---|--|
| Projection system | 3 LCD panels, 1 lens, 3 primary color shutter system |
| LCD panel | 0.79-inch XGA panel, about 2,359,296 pixels (786,432 pixels × 3) |
| Lens | 1.2 times zoom lens (powered) f=23.5 to 28.2 mm/F1.6 to 1.78 |
| Lamp | 190 W Ultra high pressure lamp |
| Projected picture size | 40 to 300 inches (measured diagonally) |
| Light output | 3000 ANSI lumen (VPL-CX63) 2500 ANSI lumen (VPL-CX61) (When the Lamp Mode is set to "High.") |
| Throwing distance (When placed on the floor.) | When an XGA signal is input 40-inch: 1.2 to 1.4 m (3.9 to 4.6 feet) 60-inch: 1.8 to 2.0 m (5.9 to 6.6 feet) 80-inch: 2.4 to 2.7 m (7.9 to 8.9 feet) 100-inch: 3.0 to 3.4 m (9.8 to 11.2 feet) 120-inch: 3.6 to 4.1 m (11.8 to 13.5 feet) 150-inch: 4.5 to 5.2 m (14.8 to 17.1 feet) 180-inch: 5.4 to 6.2 m (17.7 to 20.3 feet) 200-inch: 6.0 to 6.9 m (19.7 to 22.6 feet) 250-inch: 7.5 to 8.7 m (24.6 to 28.5 feet) 300-inch: 9.0 to 10.4 m (29.5 to 34.1 feet) |

There may be a slight difference between the actual value and the design value shown above.

Electrical characteristics

| | |
|--------------|---|
| Color system | NTSC _{3.58} /PAL/SECAM/ NTSC _{4.43} /PAL-M/PAL-N/ PAL60 system, switched automatically/manually (NTSC _{4.43} is the color system used when playing back a video recorded in NTSC on a NTSC _{4.43} system VCR.) |
| Resolution | 750 horizontal TV lines (Video input) 1,024 × 768 dots (RGB input) |

Acceptable computer signals²⁾

fH: 19 to 92 kHz

fV: 48 to 92 Hz

(Maximum input signal resolution:

SXGA+ 1400 × 1050

fV: 60 Hz)

²⁾ Set the resolution and the frequency of the signal of the connected computer within the range of acceptable preset signals of the projector.

Applicable video signals

15 k RGB 50/60 Hz, Progressive
component 50/60 Hz, DTV
(480/60i, 575/50i, 480/60p,
575/50p, 540/60p, 720/60p,
720/50p, 1080/60i, 1080/50i),
Composite video, Y/C video

Speaker Monaural speaker system, 40 × 20
mm (1 5/8 × 13/16 inches)

Speaker output
1 W (max.)

Input/Output

| | |
|-------------|---|
| Video input | VIDEO: phono type Composite video: 1 Vp-p ±2 dB sync negative (75 ohms terminated) S VIDEO: Y/C mini DIN 4-pin type Y (luminance): 1 Vp-p ±2 dB sync negative (75 ohms terminated) C (chrominance): burst 0.286 Vp-p ±2 dB (NTSC) (75 ohms terminated), burst 0.3 Vp-p ±2 dB (PAL) (75 ohms terminated) AUDIO: stereo minijack 500 mVrms, impedance more than 47 kilohms |
| INPUT A | HD D-sub 15-pin (female) Analog RGB/component: R/R-Y: 0.7 Vp-p ±2 dB (75 ohms terminated) G: 0.7 Vp-p ±2 dB (75 ohms terminated) G with sync/Y: 1 Vp-p ±2 dB sync negative (75 ohms terminated) B/B-Y: 0.7 Vp-p ±2 dB (75 ohms terminated) SYNC/HD: Composite sync input: 1-5 Vp-p high impedance, positive/ negative Horizontal sync input: 1-5 Vp-p high impedance, positive/ negative |

VD:
Vertical sync input: 1-5 Vp-p
high impedance, positive/
negative

AUDIO: Stereo minijack
(Common INPUT A/B), rated
input 500 mVrms, input
impedance 47 kilohms

INPUT B Analog RGB: HD D-sub 15-pin
(female)
R: 0.7 Vp-p ±2 dB (75 ohms
terminated)
G: 0.7 Vp-p ±2 dB (75 ohms
terminated)
G with sync: 1 Vp-p ±2 dB sync
negative (75 ohms terminated)
B: 0.7 Vp-p ±2 dB (75 ohms
terminated)
SYNC HD: Composite sync
input: 1 - 5 Vp-p high
impedance, positive/negative
Horizontal sync input: 1 - 5
Vp-p high impedance, positive/
negative
VD: Vertical sync input: 1 - 5
Vp-p high impedance, positive/
negative

OUTPUT MONITOR OUT: HD D-sub 15-
pin (female)
R, G, B: Gain Unity: 75 ohms
SYNC/HD, VD: 4 Vp-p (open),
1 Vp-p (75 ohms)
AUDIO OUT (variable out):
Stereo minijack
1 Vrms (When the volume is
maximum and an input signal is
500 mVrms), output impedance
5 kilohms

REMOTE RS-232C: D-sub 9 pin
Safety regulations
UL60950, cUL (CSA No. 60950),
FCC Class B, IC Class B,
DEMKO (EN60950), CE
(LVD, EMC), C-Tick

General

Dimensions 328 × 92.6 × 283.8 mm (13 × 3 3/4
× 11 1/4 inches) (w/h/d)
(without the projection parts)

Mass Approx. 3.7 kg (8 lb 3 oz)

Power requirements
AC 100 to 240 V, 2.8 to 1.2 A,
50/60 Hz

Power consumption
Max. 280 W
(in standby (standard): 5W
in standby (low): 0.5 W)

Heat dissipation
921.3 BTU

Operating temperature
0°C to 35°C (32°F to 95°F)

Operating humidity
35% to 85% (no condensation)

Storage temperature
-20°C to +60°C (-4°F to +140°F)

Storage humidity
10% to 90%

Supplied accessories
Remote Commander (1)
Lithium battery CR2025 (1)
HD D-sub 15 pin cable (2 m) (1)
(1-791-992-xx)
Lens cap (1)
AC power cord (1)
Air filter (for replacement) (1)
Operating Instructions (CD-ROM)
(1)
Quick Reference Manual (1)
Safety Regulations (1)
Security Label (1)

Design and specifications are subject to change
without notice.

Optional accessories

Projector Lamp
LMP-C190 (for replacement)

*Some of the items may not be available in
some areas. For details, please consult your
nearest Sony dealer.*

Pin assignment

**INPUT A connector (HD D-sub 15-pin,
female)**

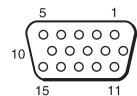

| | | | |
|---|---------|----|-----------|
| 1 | R/R-Y | 9 | N.C. |
| 2 | G/Y | 10 | GND |
| 3 | B/B-Y | 11 | GND |
| 4 | GND | 12 | DDC/SDA |
| 5 | GND | 13 | HD/C.Sync |
| 6 | GND (R) | 14 | VD |
| 7 | GND (G) | 15 | DDC/SCL |
| 8 | GND (B) | | |

Others

**INPUT B connector (HD D-sub 15-pin,
female)**

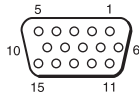

| | | | |
|---|---------|----|-----------|
| 1 | R | 9 | N.C. |
| 2 | G | 10 | GND |
| 3 | B | 11 | GND |
| 4 | GND | 12 | DDC/SDA |
| 5 | GND | 13 | HD/C.Sync |
| 6 | GND (R) | 14 | VD |
| 7 | GND (G) | 15 | DDC/SCL |
| 8 | GND (B) | | |

**RS-232C connector (D-sub 9 pin,
female)**

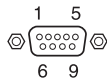

| | | | |
|---|------|---|-----|
| 1 | DCD | 6 | DSR |
| 2 | RXDA | 7 | RTS |
| 3 | TXDA | 8 | CTS |
| 4 | DTR | 9 | RI |
| 5 | GND | | |

Preset signals

| Memory No. | Preset signal | | fH (kHz) | fV (Hz) | Sync | SIZE |
|------------------|---------------|--------------------|----------|---------|----------------------------|------|
| 1 | Video 60 Hz | 60 Hz | 15.734 | 59.940 | | |
| 2 | Video 50 Hz | 50 Hz | 15.625 | 50.000 | | |
| 3 | 480/60i | 480/60i | 15.734 | 59.940 | S on G/Y or Composite Sync | |
| 4 | 575/50i | 575/50i | 15.625 | 50.000 | S on G/Y or Composite Sync | |
| 5 | 1080/60i | 1035/60i, 1080/60i | 33.750 | 60.000 | S on G/Y | |
| 6 | 640 × 350 | VGA mode 1 | 31.469 | 70.086 | H-pos, V-neg | 800 |
| 7 | | VGA VESA 85 Hz | 37.861 | 85.080 | H-pos, V-neg | 832 |
| 8 | 640 × 400 | PC-9801 Normal | 24.823 | 56.416 | H-neg, V-neg | 848 |
| 9 | | VGA mode 2 | 31.469 | 70.086 | H-neg, V-pos | 800 |
| 10 | | VGA VESA 85 Hz | 37.861 | 85.080 | H-neg, V-pos | 832 |
| 11 | 640 × 480 | VGA mode 3 | 31.469 | 59.940 | H-neg, V-neg | 800 |
| 12 | | Macintosh 13" | 35.000 | 66.667 | H-neg, V-neg | 864 |
| 13 | | VGA VESA 72 Hz | 37.861 | 72.809 | H-neg, V-neg | 832 |
| 14 | | VGA VESA 75 Hz | 37.500 | 75.000 | H-neg V-neg | 840 |
| 15 | | VGA VESA 85 Hz | 43.269 | 85.008 | H-neg V-neg | 832 |
| 16 | 800 × 600 | SVGA VESA 56 Hz | 35.156 | 56.250 | H-pos, V-pos | 1024 |
| 17 | | SVGA VESA 60 Hz | 37.879 | 60.317 | H-pos, V-pos | 1056 |
| 18 | | SVGA VESA 72 Hz | 48.077 | 72.188 | H-pos, V-pos | 1040 |
| 19 | | SVGA VESA 75 Hz | 46.875 | 75.000 | H-pos, V-pos | 1056 |
| 20 | | SVGA VESA 85 Hz | 53.674 | 85.061 | H-pos, V-pos | 1048 |
| 21 | 832 × 624 | Macintosh 16" | 49.724 | 74.550 | H-neg, V-neg | 1152 |
| 22 ^{*1} | 1024 × 768 | XGA VESA 43 Hz | 35.524 | 86.958 | H-pos, V-pos | 1264 |
| 23 | | XGA VESA 60 Hz | 48.363 | 60.004 | H-neg V-neg | 1344 |
| 24 | | XGA VESA 70 Hz | 56.476 | 69.955 | H-neg V-neg | 1328 |
| 25 | | XGA VESA 75 Hz | 60.023 | 75.029 | H-pos, V-pos | 1312 |
| 26 | | XGA VESA 85 Hz | 68.677 | 84.997 | H-pos, V-pos | 1376 |
| 27 | 1152 × 864 | SXGA VESA 70 Hz | 63.995 | 70.019 | H-pos, V-pos | 1472 |
| 28 | | SXGA VESA 75 Hz | 67.500 | 75.000 | H-pos, V-pos | 1600 |
| 29 | | SXGA VESA 85 Hz | 77.487 | 85.057 | H-pos, V-pos | 1568 |
| 30 | 1152 × 900 | Sunmicro LO | 61.795 | 65.960 | H-neg, V-neg | 1504 |
| 31 | | Sunmicro HI | 71.713 | 76.047 | Composite Sync | 1472 |

Others

| Memory No. | Preset signal | | fH (kHz) | fV (Hz) | Sync | SIZE |
|------------------|---------------|------------------------------------|------------------------------------|---------|--------------|----------|
| 32 | 1280 × 960 | SXGA VESA 60 Hz | 60.000 | 60.000 | H-pos, V-pos | 1800 |
| 33 | | SXGA VESA 75 Hz | 75.000 | 75.000 | H-pos, V-pos | 1728 |
| 34 ^{*1} | 1280 × 1024 | SXGA VESA 43 Hz | 46.433 | 86.872 | H-pos, V-pos | 1696 |
| 35 | | SXI-5 | 53.316 | 50.062 | S on G | 1680 |
| 36 | | SXGA VESA 60 Hz | 63.974 | 60.013 | H-pos, V-pos | 1696 |
| 37 | | SXGA VESA 75 Hz | 79.976 | 75.025 | H-pos, V-pos | 1688 |
| 38 ^{*2} | | SXGA VESA 85 Hz | 91.146 | 85.024 | H-pos, V-pos | 1476 |
| 43 | | 480/60p | 480/60p (Progressive component) | 31.470 | 60.000 | S on G/Y |
| 44 | 575/50p | 575/50p (Progressive component) | 31.250 | 50.000 | S on G/Y | |
| 45 | 1080/50i | 1080/50i | 28.130 | 50.000 | S on G/Y | |
| 47 | 720/60p | 720/60p | 45.000 | 60.000 | S on G/Y | |
| 48 | 720/50p | 720/50p | 37.500 | 50.000 | S on G/Y | |
| 50 | 540/60p | 540/60p | 33.750 | 60.000 | S on G/Y | |
| 52 | 1400 × 1050 | SXGA+ 60 Hz | 63.981 | 60.020 | H-pos, V-pos | 1688 |

Notes

- When a signal other than the preset signals shown above is input, the picture may not be displayed properly.
- Memory No. 22^{*1} and 34^{*1} show the interlace signal.
- For the Memory No. 38^{*2}, the smart APA function and the APA key of the remote commander do not activate. Make adjustments for the input signals using the Adjust Signal... on the INPUT SETTING menu.
- When an SXGA+ signal is input, the image may extend beyond the edges of the screen. In this case, input a signal with no black edges around the image, and disconnect and reconnect the cable or select the input signal by pressing the INPUT key.

Warning on power connection

Use the supplied power cord when you use the projector in your country/region. Otherwise, use a proper power cord meeting the following specifications.

| | The United States, Canada | | Continental Europe | | UK, Ireland, Australia, New Zealand | Japan |
|----------------------------|--|----------|--------------------|----------|---|---------|
| Plug type | VM0233 | 290B | YP-12A | COX-07 | — ¹⁾ | YP332 |
| Female end | VM0089 | 386A | YC-13B | COX-02 | VM0310B | YC-13 |
| Cord type | SJT | SJT | H05VV-F | H05VV-F | N13237/CO-228 | VCTF |
| Rated Voltage & Current | 10A/125V | 10A/125V | 10A/250V | 10A/250V | 10A/250V | 7A/125V |
| Safety approval | UL/CSA | UL/CSA | VDE | VDE | VDE | DENAN |
| Cord length (max.) | 4.5 m (177 ¹ / ₄ inches) | | — | | | |

¹⁾ Use the correct plug for your country/region.

Others

Installation Diagram

Floor Installation (Front Projection)

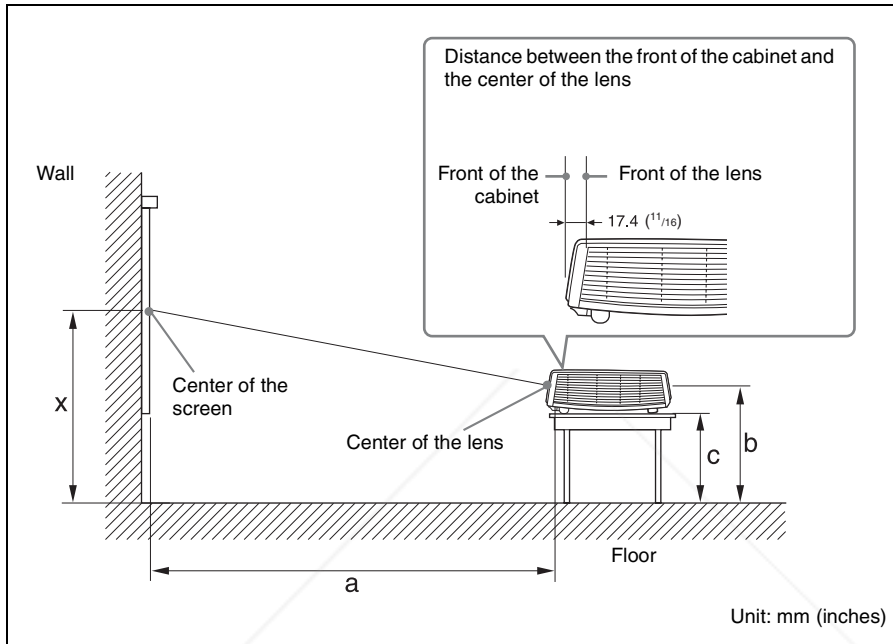

This section describes the examples of installing the projector on a desk, etc.

See the chart on page 51 concerning the installation measurements.

The alphabetical letters in the illustration indicate the distances below.

- a:** distance between the screen and the center of the lens
- b:** distance between the floor and the center of the lens
- c:** distance between the floor and the bottom of the adjusters of the projector
- x:** distance between the floor and the center of the screen (free)

Unit: mm (inches)

| SS | | 40 | 60 | 80 | 100 | 120 | 150 | 180 | 200 | 250 | 300 |
|----------|----------|---------------------|---------------------|---------------------|---------------------|---------------------|---------------------|----------------------|----------------------|----------------------|----------------------|
| a | N | 1160 (45 3/4) | 1760 (69 3/8) | 2360 (93) | 2970 (117) | 3570 (140 5/8) | 4470 (176 1/8) | 5380 (211 7/8) | 5980 (235 1/2) | 7490 (295) | 9000 (354 3/8) |
| | M | 1350 (53 1/4) | 2040 (80 3/8) | 2740 (108) | 3440 (135 1/2) | 4140 (163 1/8) | 5180 (204) | 6230 (245 3/8) | 6930 (272 7/8) | 8670 (341 1/2) | 10420 (410 3/8) |
| b | | x-237 (x-9 3/8) | x-356 (x-14) | x-474 (x-18 3/4) | x-593 (x-23 3/8) | x-711 (x-28) | x-889 (x-35) | x-1067 (x-42) | x-1185 (x-46 3/4) | x-1482 (x-58 3/8) | x-1778 (x-70 1/8) |
| c | | x-299 (x-11 7/8) | x-417 (x-16 1/2) | x-536 (x-21 1/8) | x-654 (x-25 7/8) | x-773 (x-30 1/2) | x-951 (x-37 1/2) | x-1129 (x-44 1/2) | x-1247 (x-49 1/8) | x-1543 (x-60 7/8) | x-1840 (x-72 1/2) |

$$a (N) = \{(SS \times 23.177/0.7874) - 50.4\} \times 1.025$$

$$a (M) = \{(SS \times 28.177/0.7874) - 50.4\} \times 0.975$$

$$b = x - (SS/0.7874 \times 4.667)$$

$$c = x - (SS/0.7874 \times 4.667 + 61.8)$$

The installation measurements and their calculation method for each lens are shown above.

The alphabetical letters in the charts and calculation methods indicate the following.

SS: screen size measured diagonally (inches)

a: distance between the screen and the center of the lens

b: distance between the floor and the center of the lens

c: distance between the floor and the adjusters of the projector

x: free

N: minimum

M: maximum



Ceiling Installation (Front Projection)

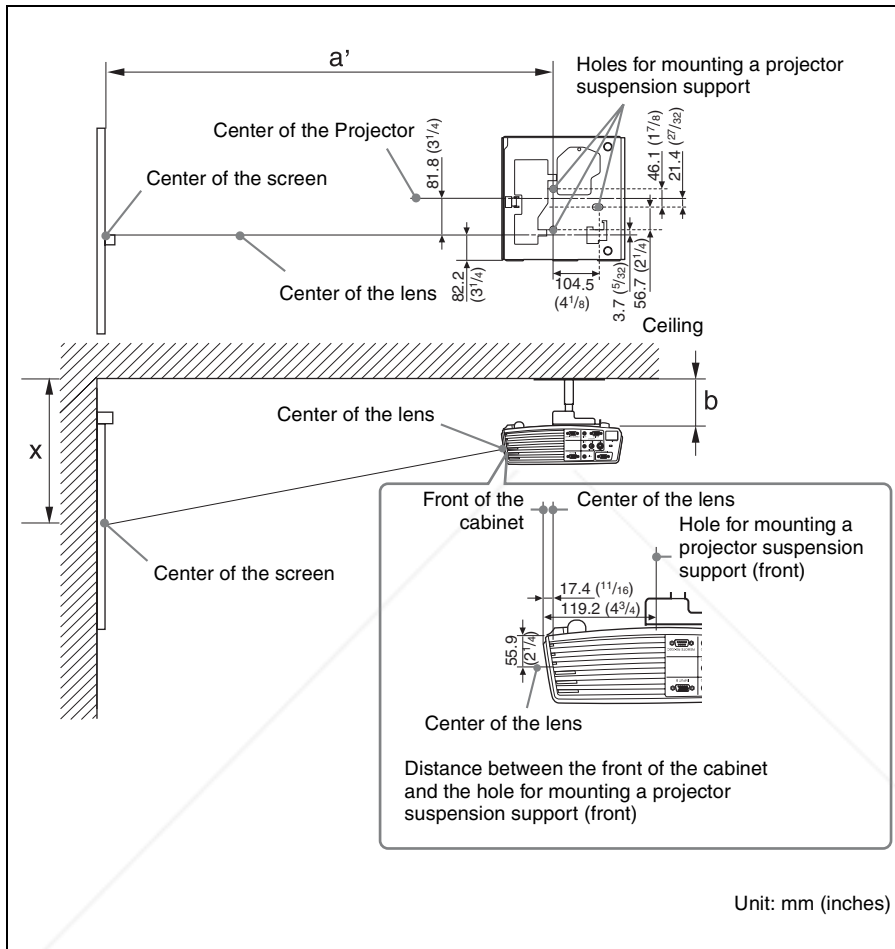

This section describes the examples for installing the projector on the ceiling. When installing the projector on the ceiling, use a Projector Suspension Support recommended by Sony.

For ceiling installation, ask for qualified Sony personnel. See the chart on page 53 concerning the installation measurements.

The alphabetical letters in the illustrations indicate the distances below.

a': distance between the hole (front) for mounting a projector suspension support on bottom surface of this projector and the center of the screen

b: distance between the hole (front) for mounting a projector suspension support on bottom surface of this projector and the ceiling

x: distance between the ceiling and the center of the screen

Unit: mm (inches)

| SS | | 40 | 60 | 80 | 100 | 120 | 150 | 180 | 200 | 250 | 300 |
|----|---|---------------------|---------------------|---------------------|---------------------|---------------------|---------------------|----------------------|----------------------|----------------------|----------------------|
| a' | N | 1260 (49 5/8) | 1860 (73 1/4) | 2470 (97 3/8) | 3070 (121) | 3670 (144 5/8) | 4580 (180 3/8) | 5480 (215 7/8) | 6090 (239 7/8) | 7600 (299 1/4) | 9100 (358 3/8) |
| | M | 1450 (57 1/8) | 2140 (84 3/8) | 2840 (111 7/8) | 3540 (139 1/2) | 4240 (167) | 5280 (208) | 6330 (249 1/4) | 7030 (276 13/16) | 8770 (345 3/8) | 10520 (414 1/4) |
| x | | b+293 (b+11 3/8) | b+411 (b+16 1/4) | b+530 (b+20 7/8) | b+649 (b+25 5/8) | b+767 (b+30 1/4) | b+945 (b+37 1/4) | b+1123 (b+44 1/4) | b+1241 (b+48 7/8) | b+1538 (b+60 5/8) | b+1834 (b+72 1/4) |
| b | | Free | | | | | | | | | |

$$a'(N) = \{(SS \times 23.177/0.7874)+51.4\} \times 1.025$$

$$a'(M) = \{(SS \times 28.177/0.7874)+51.4\} \times 0.975$$

$$x = b + (SS/0.7874 \times 4.667+55.8)$$

The installation measurements and their calculation method for each lens are shown above.

The alphabetical letters in the charts and calculation methods indicate the following.

SS: screen size measured diagonally (inches)

a': distance between the hole (front) for mounting a projector suspension support on bottom surface of this projector and the center of the screen

b: distance between the hole (front) for mounting a projector suspension support on bottom surface of this projector and the ceiling

x: distance between the center of the screen and the ceiling

N: minimum

M: maximum



Dimensions

Front

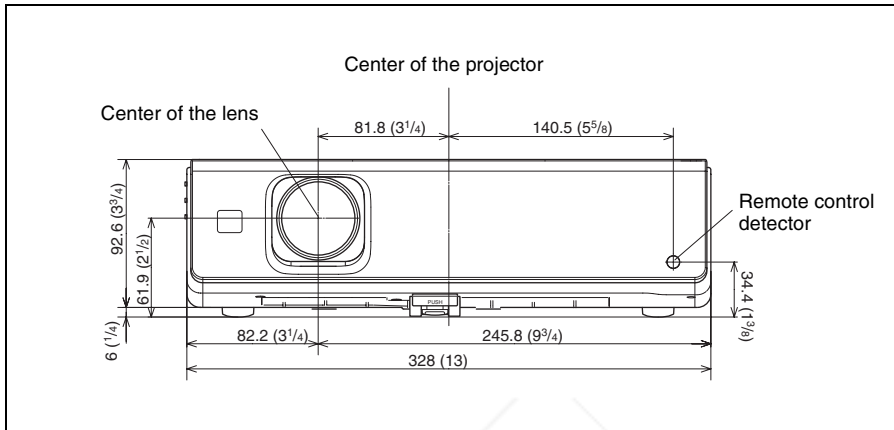

Right side

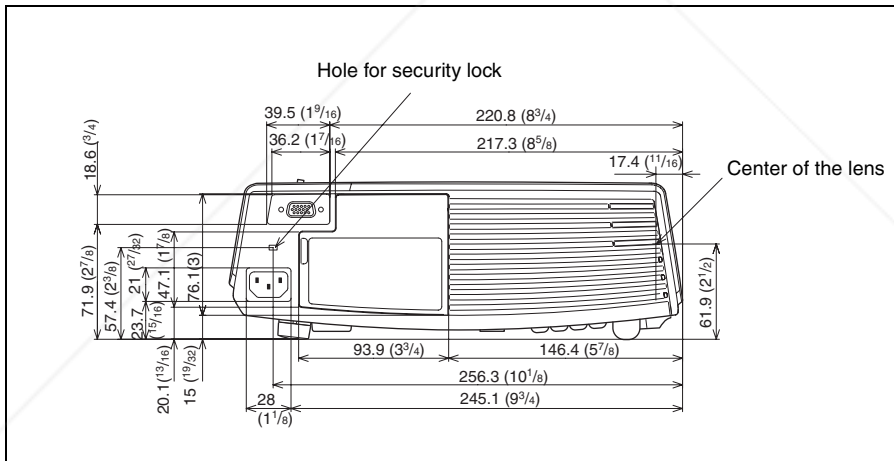

Unit: mm (inches)

Left side

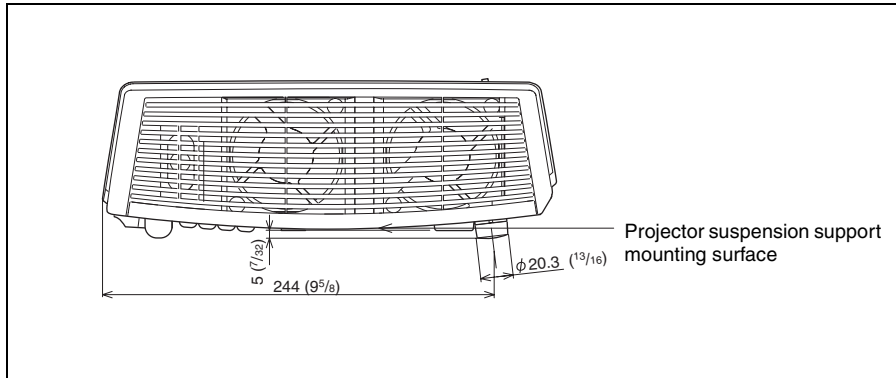

Bottom

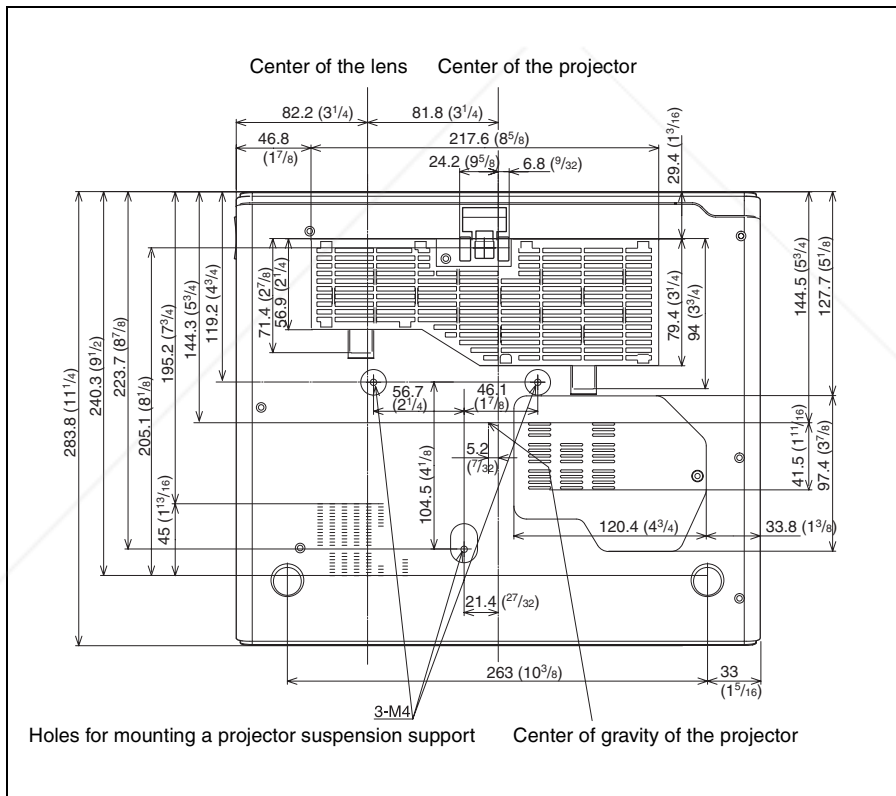

Unit: mm (inches)

Index

A

| | |
|------------------------------|--------|
| Adjuster | 18 |
| Adjusting | |
| memory of the settings | 25 |
| the picture | 26 |
| the picture size/shift | 27, 28 |
| Air filter | 38 |
| Auto Input Search | 29 |

B

| | |
|------------------|----|
| Background | 32 |
| Batteries | 13 |
| Brightness | 26 |

C

| | |
|-----------------------------|----|
| Color | 26 |
| Color System | 29 |
| Color Temp. | 26 |
| Connecting a computer | 15 |
| Connecting a VCR | 16 |
| Contrast | 26 |

D

| | |
|-----------------------------|--------|
| Digital Zoom function | 23 |
| Direct Power On | 32 |
| Dot Phase | 27, 28 |

F

| | |
|---------------------------------|----|
| fH (Horizontal Frequency) | 34 |
| fV (Vertical Frequency) | 34 |

G

| | |
|------------------|----|
| Gamma Mode | 26 |
|------------------|----|

H

| | |
|--------------------------|--------|
| H Size | 27, 28 |
| High Altitude Mode | 32, 33 |
| Hue | 26 |

I

| | |
|-----------------------------|----|
| Image Flip | 32 |
| Input-A Signal Sel. | 29 |
| Installation | 14 |
| notes | 6 |
| unsuitable conditions | 7 |

| | |
|-------------------------------|---|
| unsuitable installation | 6 |
|-------------------------------|---|

L

| | |
|-----------------------------------|----|
| Lamp Mode | 32 |
| Lamp replacement | 36 |
| Lamp Timer | 34 |
| Language | 31 |
| selecting the menu language | 20 |
| Lens Control | 32 |
| Location and function of controls | |
| connector panel | 11 |
| control panel | 10 |
| rear/right side/bottom | 9 |
| Remote Commander | 12 |
| top/front/left side | 9 |

M

| | |
|---------------------------------|----|
| Menu | |
| clearing the menu display | 25 |
| INFORMATION Menu | 34 |
| INPUT SETTING menu | 27 |
| INSTALL SETTING menu | 32 |
| MENU SETTING menu | 31 |
| PICTURE SETTING menu | 26 |
| SET SETTING menu | 29 |
| using the menu | 24 |
| Menu Color | 31 |
| Menu Position | 31 |
| Message List | |
| caution | 43 |
| warning | 42 |

O

| | |
|----------------------------|----|
| Off & Go function | 22 |
| Optional accessories | 45 |

P

| | |
|---|----|
| Panel Key Lock | 30 |
| Picture Mode | 26 |
| Pin assignment | 45 |
| Power | |
| turn on | 17 |
| Power consumption in standby mode | 30 |
| Power Saving | 30 |
| Projecting | 17 |

R

| | |
|---|----|
| Remote Commander | 12 |
| front remote control detector | 9 |
| location and function of controls | 12 |



FixYourDLP.com

Sponsored by



notes

Discount-Merchant.com (800) 281-8860

THE TRUSTED SOURCE FOR PROJECTOR LAMPS AND ACCESSORIES

rear remote control detector 10
Reset
 resettable items 25
 resetting an item 25

S

Scan Converter 28
Screen size 14, 44
Security Lock 33
Sharpness 26
Shift 28
Smart APA 29
Specifications 44
Status 31
Supplied accessories 45

T

Test Pattern 32
Troubleshooting 39

V

V Keystone 32
Volume 26

W

Wide Mode 27



Discount-Merchant.com (800) 281-8860
THE TRUSTED SOURCE FOR PROJECTOR LAMPS AND ACCESSORIES



Discount-Merchant.com (800) 281-8860
Sony Corporation <http://www.sony.net/>
THE TRUSTED SOURCE FOR PROJECTOR LAMPS AND ACCESSORIES

VPL-CX63/CX61
2-684-389-11 (1)



Disclaimer

This user manual is provided as a free service by FixYourDLP.com. FixYourDLP is in no way responsible for the content of this manual, nor do we guarantee its accuracy. FixYourDLP does not make any claim of copyright and all copyrights remain the property of their respective owners.

About FixYourDLP.com

FixYourDLP.com (<http://www.fixyourdlp.com>) is the World's #1 resource for media product news, reviews, do-it-yourself guides, and manuals.

Informational Blog: <http://www.fixyourdlp.com>

Video Guides: <http://www.fixyourdlp.com/guides>

User Forums: <http://www.fixyourdlp.com/forum>

FixYourDLP's Fight Against Counterfeit Lamps:

<http://www.fixyourdlp.com/counterfeits>

Sponsors:

RecycleYourLamp.org – Free lamp recycling services for used lamps:

<http://www.recycleyourlamp.org>

Lamp Research - The trusted 3rd party lamp research company:

<http://www.lampresearch.com>

Discount-Merchant.com – The worlds largest lamp distributor:

<http://www.discount-merchant.com>



FixYourDLP.com

Sponsored by 