



Disclaimer

This user manual is provided as a free service by FixYourDLP.com. FixYourDLP is in no way responsible for the content of this manual, nor do we guarantee its accuracy. FixYourDLP does not make any claim of copyright and all copyrights remain the property of their respective owners.

About FixYourDLP.com

FixYourDLP.com (<http://www.fixyourdpl.com>) is the World's #1 resource for media product news, reviews, do-it-yourself guides, and manuals.

Informational Blog: <http://www.fixyourdpl.com>

Video Guides: <http://www.fixyourdpl.com/guides>

User Forums: <http://www.fixyourdpl.com/forum>

FixYourDLP's Fight Against Counterfeit Lamps:

<http://www.fixyourdpl.com/counterfeits>

Sponsors:

RecycleYourLamp.org – Free lamp recycling services for used lamps:

<http://www.recycleyourlamp.org>

Lamp Research - The trusted 3rd party lamp research company:

<http://www.lampresearch.com>

Discount-Merchant.com – The worlds largest lamp distributor:

<http://www.discount-merchant.com>



FixYourDLP.com

Sponsored by 

proxima®

Own your audience.

Main Office: 9440Carroll Park Drive, San Diego, CA 92121-2298
(858)457-5500, FAX(858)457-9647, (800)447-7692 (U.S. and Canada)

European Office: K.G. Meldahlsvei 9, Postboks 1403
N-1602 Fredrikstad, Norway, +47 69 6401 55, FAX + 47 69 34 06 32
Technical support & service: Horsterweg 24, 6191 RX Beek, The Netherlands, +31 43 358 5210, FAX +31 43 358 5202



www.proxima.com

www.presentersuniversity.com

Discount-Merchant.com (800) 281-8860

User's Guide 710-00866

THE TRUSTED SOURCE FOR PROJECTOR LAMPS AND ACCESSORIES



710-00866

Part No.710-00866
ULTRALIGHT S520 User's Manual.qxd
Printed in Japan

QR47451

proxima®

UltraLight S520

USER'S MANUAL

Please read this user's manual thoroughly to ensure correct usage through understanding.

BEDIENUNGSANLEITUNG

Bitte lesen Sie diese Bedienungsanleitung zugunsten der korrekten Bedienung aufmerksam.

MANUEL D'UTILISATION

Nous vous recommandons de lire attentivement ce manuel pour bien assimiler le fonctionnement de l'appareil.

MANUAL D'ISTRUZIONI

Vi preghiamo voler leggere attentamente il manuale d'istruzioni in modo tale da poter comprendere quanto riportato ai fini di un corretto utilizzo del proiettore.

MANUAL DE USUARIO

Lea cuidadosamente este manual del usuario para poder utilizar correctamente el producto.

GEBRUIKSAANWIJZNG

Lees voor het gebruik alstublieft deze handleiding aandachtig door, om volledig profijt te hebben van de uitgebreide mogelijkheden.

BRUKERHÅNDBOK

Vennligst les denne bruksanvisningen grundig for å være garantert driftssikker bruk.

INSTRUÇÕES DO PROPRIETÁRIO

Para assegurar o uso correto do equipamento, por favor leia atentamente este manual do usuário.

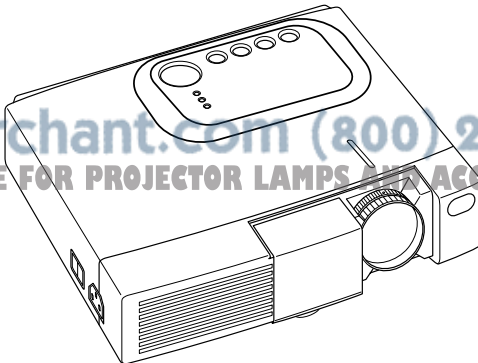

Discount-Merchant.com (800) 281-886
THE TRUSTED SOURCE FOR PROJECTOR LAMPS AND ACCESSORIES

ENGLISH

DEUTSCH

FRANÇAIS

ITALIANO

ESPAÑOL

NEDERLANDS

NORSK

PORTUGÊS

TECHNICAL

proxima® UltraLight S520

USER'S MANUAL

ENGLISH

Thank you for purchasing this PROXIMA liquid crystal projector.



Please read the "SAFETY INSTRUCTIONS" and this "USER'S MANUAL" thoroughly to ensure correct usage through understanding. After reading, store this instruction manual in a safe place for future reference.

NOTE:

- * The information in this manual is subject to change without notice.
- * The manufacturer assumes no responsibility for any errors that may appear in this manual
- * The reproduction, transmission or use of this documents or contents is not permitted without express written authority.

TRADEMARK ACKNOWLEDGMENT:

- * PS/2, VGA and XGA are registered trademark of International Business Machines Corporation.
- * Apple, Macintosh, Mac and ADB are registered trademarks of Apple Computer, Inc.
- * VESA and SVGA are trademarks of the Video Electronics Standard Association.
- * Windows is registered trademarks of Microsoft Corporation.
- * Carefully observe the trademarks and registered trademarks of all companies, even when not mentioned.

CONTENTS

FEATURESP.2

BEFORE USEP.2

| | |
|--------------------------|-----|
| Contents of Package..... | P.2 |
| Part Names..... | P.3 |
| Loading the Battery..... | P.4 |

INSTALLATIONP.5

| | |
|---|-----|
| Installation of the projector and Screen..... | P.5 |
| Angle Adjustment..... | P.5 |
| Cabling..... | P.6 |
| Power Connection..... | P.6 |
| Example of System Setup..... | P.7 |
| Plug & Play..... | P.7 |

OPERATIONS.....P.8

| | |
|---------------------------------------|------|
| Switching the Power Supply ON/OFF.... | P.8 |
| Basic Operation..... | P.9 |
| Setup Menu..... | P.11 |
| Input Menu..... | P.12 |
| Image Menu..... | P.13 |
| Options Menu..... | P.14 |
| No Signal Menu..... | P.15 |

MAINTENANCE.....P.16

| | |
|-----------------------------|------|
| Lamp..... | P.16 |
| Air Filter Maintenance..... | P.18 |
| Other Maintenance..... | P.18 |

TROUBLESHOOTING.....P.19

| | |
|-------------------------|------|
| OSD Message..... | P.19 |
| Indicators Message..... | P.20 |
| Symptom..... | P.21 |

SPECIFICATIONSP.22

WARRANTY AND AFTER-SERVICE...P.23

REGULATORY NOTICESP.24

Tables:

| | |
|--------------------------------------|------|
| Table 1. Installation Reference..... | P.5 |
| Table 2. Basic Operations..... | P.9 |
| Table 3. Setup Menu..... | P.11 |
| Table 4. Input Menu..... | P.12 |
| Table 5. Image Menu..... | P.13 |
| Table 6. Options Menu..... | P.14 |
| Table 7. No Signal Menu..... | P.15 |
| Table 8. OSD Message..... | P.19 |
| Table 9. Indicator Message..... | P.20 |
| Table 10. Symptom..... | P.21 |
| Table 11. Specifications..... | P.22 |

FEATURES

This liquid crystal projector is used to project various computer signals as well as NTSC / PAL / SECAM video signals onto a screen. Little space is required for installation and large images can easily be realized.

- **Outstanding brightness**

The UHB lamp and high-efficiency optical system assure a high level of brightness.

- **Partial magnification function**

Interesting parts of images can be magnified for closer viewing.

- **Distortion correction function**

Distortion-free images are quickly available.

BEFORE USE

Contents of package

Make sure all of the following items are included in the package. If anything is missing, please contact your dealer.

NOTE: Keep the original packing material for future reshipment.

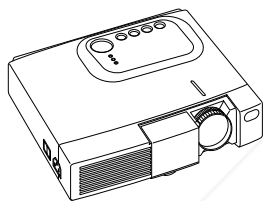

Projector

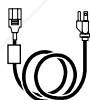

**Power Cord
US Type**



**Power Cord
Europe Type**

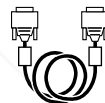

RGB Cable



**User's Manual
(this manual)**

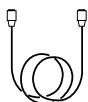

S-Video Cable

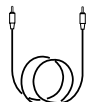

Video Cable

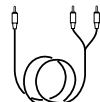

**Audio Cable
(RCA / Mini)**

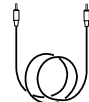

**Audio Cable
(Mini / Mini)**



Safety Instructions



Mac Adapter



Registration Card

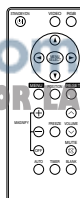

**Remote Controller
containing Battery**



Carrying Bag

Part Names

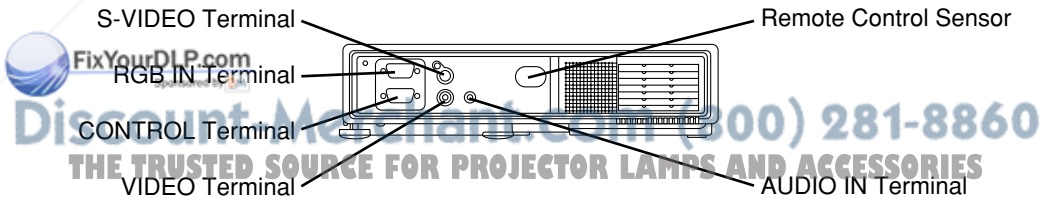
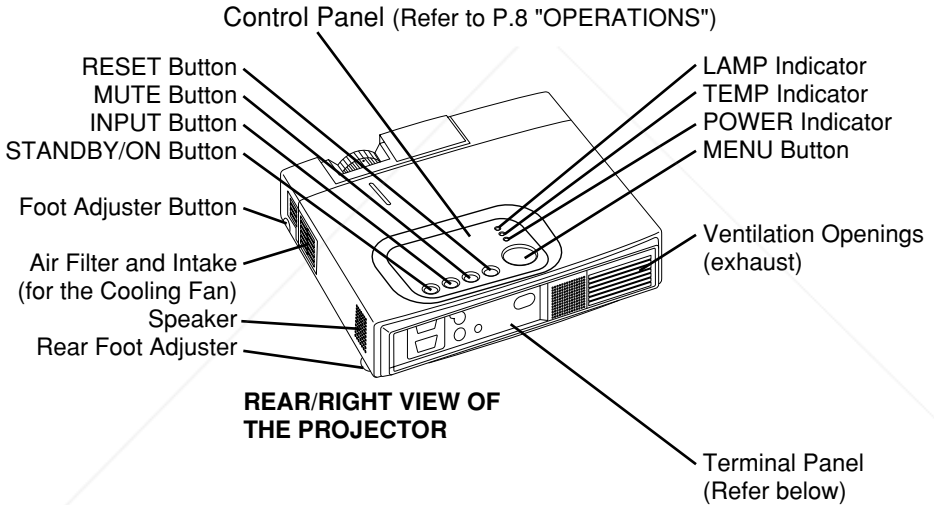
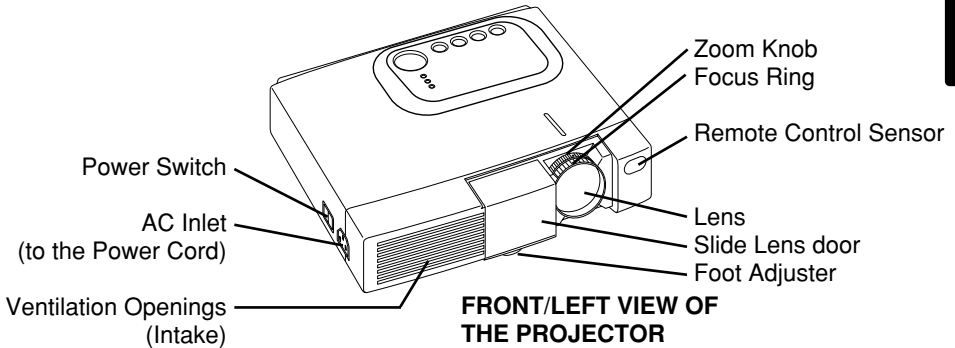

TERMINAL PANEL

BEFORE USE (continued)

Part Names (continued)

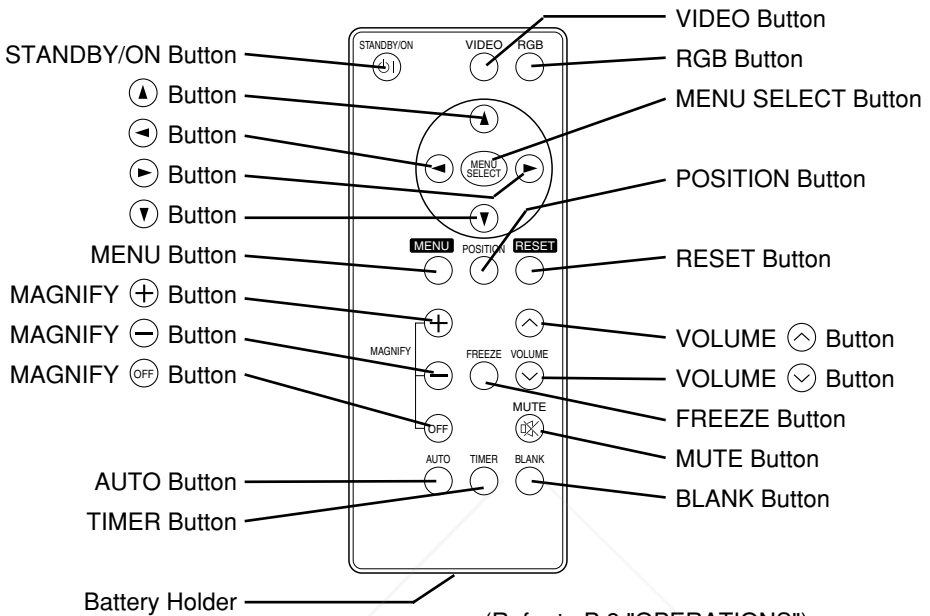

(Refer to P.8 "OPERATIONS")

REMOTE CONTROLLER

Loading the Battery

CAUTION

Danger of explosion if battery is incorrectly replaced.

Be careful in handling the battery according to instructions of the accompanying manual "SAFETY INSTRUCTIONS" and this manual.



Replace only with the same or equivalent type recommended by the manufacturer.

Use the 3V micro lithium battery type no. CR2025 only.

When you dispose the battery, you must obey the law in the relative area or country.

Keep the battery away from children and pets.

First Loading:

Remove the battery from the original packing, the battery is installed in the battery holder of the remote controller with protection film (the transparent film) some of which is inside the battery folder. Pull out the protection film to load the battery.

Replacing:

1. See the reverse side of the remote controller.
2. Pinch the groove and pull out battery holder as the drawing right.
3. Remove the worn battery.
4. Install the new battery with "+" side facing.
5. Push in and click the battery holder.

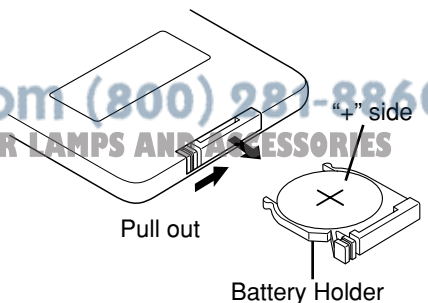

INSTALLATION

Installation of the Projector and Screen



Install the projector in a suitable environment according to instructions of the accompanying manual “SAFETY INSTRUCTIONS” and this manual.

Refer to the drawing and table below for determining of the screen size and projection distance.

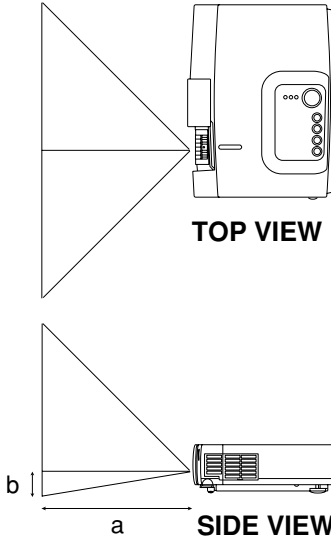

- a: Distance from the LCD projector to the screen.
The projection distance shown in the table below are for full size (800 x 600 dots).
- b: Distance from the lens center to the bottom of the screen (a, b: +/-10%)

Table 1. Installation Reference

| Screen size (inches) | a (inches) | | b (inches) |
|----------------------|------------|------|------------|
| | Min. | Max. | |
| 40 | 37 | 46 | 3 |
| 60 | 57 | 69 | 5 |
| 80 | 77 | 93 | 7 |
| 100 | 96 | 116 | 9 |
| 120 | 116 | 139 | 10 |
| 150 | 145 | 174 | 13 |
| 200 | 194 | 233 | 17 |

Installation of liquid crystal projector



Please basically use liquid crystal projector at the horizontal position.

If you use liquid crystal projector by the lens up position, the lens down position and the side up position, this may cause the heat inside to build up and become the cause of damage. Be especially careful not to install it with ventilation holes blocked.

Angle Adjustment

Use the foot adjuster on the bottom of the projector to adjust the projection angle. It is variable within 0° to 10° approximately.

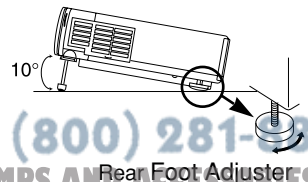
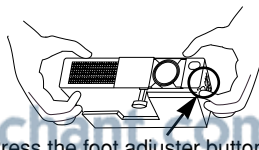
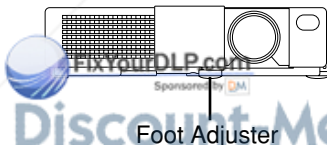

1. Lift up the front side of the projector, and pressing the foot adjuster button, adjust the projection angle.
2. Release the button to lock at the angle to be fixed.
3. Turn the rear foot adjuster to adjust the left-right slope.



Do not release the foot adjuster button unless the projector is being held; otherwise, the projector could overturn or the fingers could get caught and cause personal injury.

INSTALLATION (continued)

Cabling



* Incorrect connecting could result in fire or electrical shock. Please read this manual and the separate "SAFETY INSTRUCTIONS".

* Before connecting, turn off to all devices to be connected.



* Before connecting, read the instruction manuals of the devices to be connected, and make sure that the projector is compatible with the device.

* The cables (Power cord, RGB cable and other cables) may have to be used with the core set to the projector side. Use the cables which are included with the projector or specified.

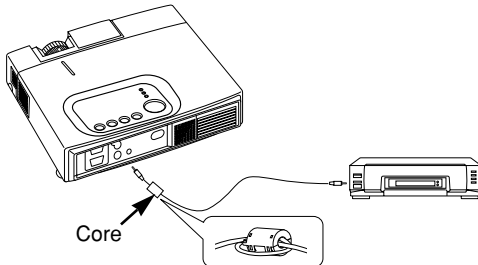

RGB Signal Input:

Connect the RGB IN terminal of the projector to the display signal output of the computer by the enclosed RGB cable. Secure the screws on the connector and tighten.

For some modes, the enclosed Mac adapter is necessary. Refer to P.22 "SPECIFICATION" and "Table 1. Example of Compatible Computer Signal" of the TECHNICAL section.

NOTE: Some computers may have multiple display screen modes. Use of some of these modes will not be possible with this projector.

Video Signal Input:

Connect the VIDEO terminal of the projector to the video signal output of the video tape recorder by the enclosed video cable except for S-Video signal.

For S-Video signal, use the S-VIDEO terminal of the projector and the optional cable for S-Video.

Audio Signal Input:

Connect the AUDIO IN terminal of the projector to the audio signal output by the enclosed audio cable.

RCA/Mini cable: to the video tape recorder

Mini/Mini cable: to the computer

RS-232C:

Connect the CONTROL terminal of the projector to the computer by the optional RS-232C cable. Refer to the manual of the RS-232C cable for the control command.

Power Connection

WARNING



Be careful in handling the power cord according to instructions of the accompanying manual "SAFETY INSTRUCTIONS" and this manual.

Connect the power cord firmly. Avoid using a loose, unsound outlet or contact failure.

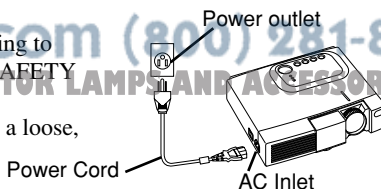

Use the correct one of the enclosed power cords depending on the power outlet to be used.

Connect the AC inlet of the projector to the power outlet firmly by the power cord.

Example of system setup

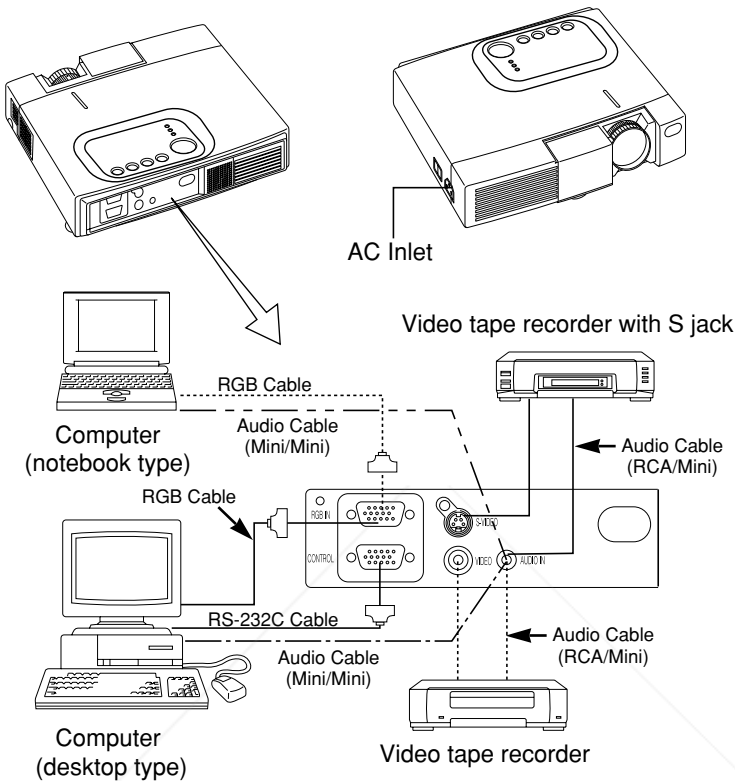

Connecting with notebook computer



When connecting with notebook computer, set to valid the RGB external image output (setting CRT display or simultaneous display of LCD and CRT).

Please read instruction manual of the notebook for more information.



Plug & Play

This projector is VESA DDC 1/2B compatible. Plug & play is possible by connecting to a computer that is VESA DDC (Display Data Channel) compatible.

(Plug & play is a system configured with peripheral equipment including a computer and display, and an operating system.)

NOTE: Use the RGB cable included with this projector when using plug & play. With other cables, pins (12) (14) (15) are sometimes not connected.

OPERATIONS



Please read this manual, and the separate “SAFETY INSTRUCTIONS” thoroughly before using the equipment. Always ensure that the equipment is used safely.

Switching the Power Supply ON/OFF

Switching Power ON

1. Check that the power cord is connected correctly.
2. Set the power switch to [I]. The standby mode is selected, and the Power indicator is turned to orange.
3. Press the STANDBY/ON  button on the control panel or the remote. Warm-up begins and the Power indicator blinks in green.
4. The Power indicator ceases blinking and turns to green when power is ON. Open the lens door.
5. Adjust picture size using the projection lens Zoom Knob.
6. Adjust focus using the projection lens Focus Ring.

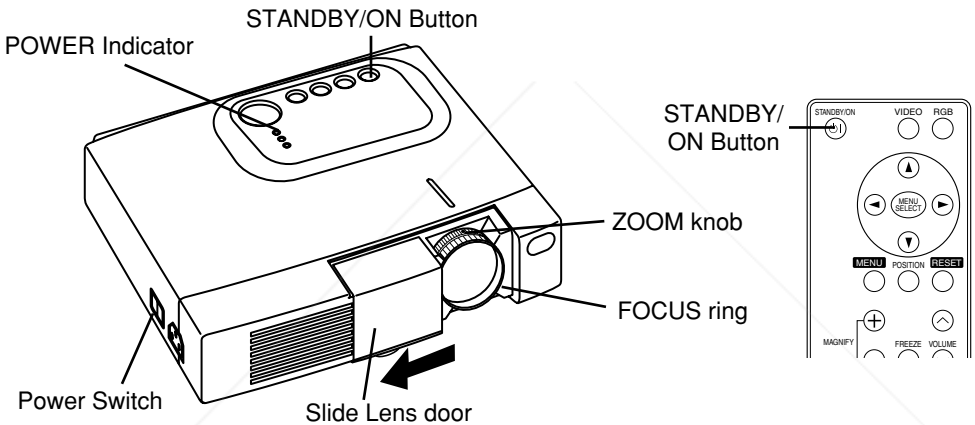

Switching Power OFF

1. Press the STANDBY/ON button on the control panel or the remote for approximately two seconds. The projector lamp is extinguished and lamp cooling begins. The Power indicator blinks orange during lamp cooling. Pressing the STANDBY/ON  button has no effect while the Power indicator is blinking.
2. The system assumes the Standby mode when cooling is complete, and the Power indicator ceases blinking and changes to orange. Check that the indicator is orange and set the Power switch to [O].
3. The Power indicator is extinguished when power is OFF. Do not forget to close the lens door.



Except in emergencies, do not switch power OFF unless the Power indicator is orange as it will reduce the life of the projector lamp.

OPERATIONS (continued)

Basic Operation

The Basic operation shown in Table 2 is performed from the projector control panel or the supplied remote. (items indicated by * may be used from the control panel)



Use the remote controller at a distance of approximately 3m from the sensor on the front of the projector, and within a range of 30° left-right. Strong light and obstacles will interfere with operation of the remote.

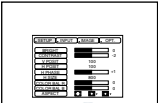

Table 2 . Basic Operation

| Item | Description |
|--------------|--|
| INPUT SELECT | Changes in input signal in sequence: Press INPUT button.* RGB → VIDEO → S-VIDEO (→ RGB) Select RGB input: Press RGB button. VIDEO/S-VIDEO → RGB Select VIDEO/S-VIDEO input: Press VIDEO button. RGB → VIDEO/S-VIDEO S-VIDEO ↔ VIDEO * The selected signal name is displayed for approximately three seconds when the input signal is changed. |
| POSITION | Set/Clear position adjustment mode: Press POSITION button. The icon is displayed in the POSITION mode. Image position adjustment: Press the , , and buttons in the position adjustment mode. * Valid only in the MAGNIFY mode with VIDEO/S-VIDEO input. * The icon is extinguished, and the position adjustment mode cleared automatically, after approximately ten seconds of inactivity. |
| RESET * | Initialise menu items: Select an item and press the RESET button. Initialise position adjustment: Press the RESET button and the POSITION mode. Valid only when RGB signal is input. * Valid except for VOLUME, LANGUAGE and H PHASE. |
| MAGNIFY | Set MAGNIFY mode: Press the MAGNIFY button. Move magnified area: Run Position Adjustment in MAGNIFY mode. Adjust magnification: Press MAGNIFY / in MAGNIFY mode. Clear MAGNIFY mode: Press MAGNIFY button. * MAGNIFY is cleared by running or setting AUTO, ASPECT, INPUT SELECT or VIDEO, or by changing the input signal. |
| FREEZE | Set/Clear FREEZE mode: Press FREEZE button. The icon is displayed, and the image frozen, in the FREEZE mode. * FREEZE is cleared by running or setting POSITION, VOLUME, MUTE, Auto Adjust, BLANK ON/OFF, or MENU ON/OFF, or by changing the input signal. * Do not forget to clear frozen static images. |

(It continue the next page.)

OPERATIONS (continued)

Table 2. Basic Operation (continued)

| Item | Description |
|---------------|---|
| VOLUME | Volume adjustment : Reduce VOLUME ☹ ↔ Increase VOLUME ☺ |
| MUTE * | Set/Clear Mute mode: Press the MUTE ☹ button. No sound is heard in the MUTE mode. |
| AUTO | Automatic adjustment at RGB input: Press the AUTO button. Horizontal position(H.POSIT), vertical position (V.POSIT),clock phase (H.PHASE), and horizontal size(H.SIZE) are automatically adjusted. Use with the window at maximum size in the application display. Automatic adjustment at VIDEO/S-VIDEO input: Press the AUTO button. A signal type appropriate for the input signal is selected automatically. Valid only when AUTO is set for VIDEO on the menu. * This operation requires approximately ten seconds. It may not function correctly with some input signals. |
| TIMER ON/OFF | Timer start/stop: Press the TIMER button. Count-down and display by the minute from the initial value (1~99) set in TIMER on the Options menu to 0. * The timer is not displayed in the BLANK MODE or FREEZE MODE. |
| BLANK ON/OFF | Set/Clear Blank mode: Press the BLANK button. No image is displayed in the Blank mode. The screen color is as set in BLANK on the Image menu. |
| MENU ON/OFF * | Menu display start/stop: Press the MENU button. * The menu display is terminated automatically after approximately ten seconds of inactivity. |
| MENU SELECT | Select menu type: Press the MENU SELECT button. Allows the user to select the normal menu or the single menu. Only the selected item is displayed on the single menu, and other items are displayed with the ⬆ and ⬇ buttons as with the normal menu. * Valid only when the Setup menu is used. Push the MENU SELECT button after selecting items such as "BRIGHTNESS". <div style="display: flex; justify-content: space-around; align-items: center;"> <div style="text-align: center;"> <p>Normal menu</p>  </div> <div style="text-align: center;"> <p>(MENU SELECT)</p>  </div> <div style="text-align: center;"> <p>Single menu</p>  </div> </div> |



Discount-Merchant.com (800) 281-8860

THE TRUSTED SOURCE FOR PROJECTOR LAMPS AND ACCESSORIES

OPERATIONS (continued)

Setup Menu

The following adjustments and settings are possible when SETUP is selected at the top of the menu. Part of the Setup menu differs between RGB input and VIDEO/S-VIDEO input. Select an item with the \blacktriangle and \blacktriangledown buttons, and start operation. Use the Single menu to reduce menu size (see Table 2 MENU SELECT).

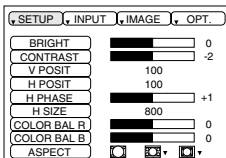

RGB

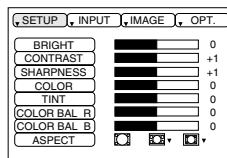

VIDEO/S-VIDEO

ENGLISH

Table 3. Setup Menu

| Item | Description | RGB | VIDEO S-VIDEO |
|-------------|---|-----|---------------|
| BRIGHT | Adjustment: Dark \blacktriangle \leftrightarrow Light \blacktriangledown | ✓ | ✓ |
| CONTRAST | Adjustment: Weak \blacktriangle \leftrightarrow Strong \blacktriangledown | ✓ | ✓ |
| V POSIT | Adjustment: Down \blacktriangle \leftrightarrow Up \blacktriangledown | ✓ | - |
| H POSIT | Adjustment: Left \blacktriangle \leftrightarrow Right \blacktriangledown | ✓ | - |
| H PHASE | Adjustment: Left \blacktriangle \leftrightarrow Right \blacktriangledown * Adjust to eliminate flicker. | ✓ | - |
| H SIZE | Adjustment: Small \blacktriangle \leftrightarrow Large \blacktriangledown * The image may not displayed correctly if the horizontal size is excessive. In such cases, press the RESET \square button, and initialise the horizontal size. | ✓ | - |
| SHARPNESS | Adjustment: Soft \blacktriangle \leftrightarrow Clear \blacktriangledown | - | ✓ |
| COLOR | Adjustment: Light \blacktriangle \leftrightarrow Dark \blacktriangledown | - | ✓ |
| TINT | Adjustment: Red \blacktriangle \leftrightarrow Green \blacktriangledown * Valid only when NTSC or NTSC 4.43 signals is received. | - | ✓ |
| COLOR BAL R | Adjustment: Light \blacktriangle \leftrightarrow Dark \blacktriangledown | ✓ | ✓ |
| COLOR BAL B | Adjustment: Light \blacktriangle \leftrightarrow Dark \blacktriangledown | ✓ | ✓ |
| ASPECT | Select image aspect ratio: 4:3 \square \leftrightarrow 16:9 \square \leftrightarrow 4:3 small \square Select position of 16:9 \square / 4:3 small \square image: Press \blacktriangledown button while 16:9 \square / 4:3 small \square is selected. Center \rightarrow \blacktriangledown Down \rightarrow \blacktriangledown Up \rightarrow Center \blacktriangledown * 4:3small may not be displayed correctly with some input signals. | ✓ | ✓ |



FixYourDLP.com

Sponsored by

DiscountMechanics.com (800) 281-8860

THE TRUSTED SOURCE FOR PROJECTOR PARTS AND ACCESSORIES

OPERATIONS (continued)

Input Menu

The following functions are available when INPUT is selected on the menu. Select an item with the \uparrow and \downarrow buttons, and start or stop operation with the \leftarrow and \rightarrow buttons.

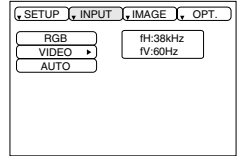

Table 4. Input Menu

| Item | Description |
|-------|--|
| RGB | <p>Displays RGB input frequency: Displays the horizontal and vertical sync signal frequency for RGB input.</p> <p>* Valid only at RGB input.</p> |
| VIDEO | <p>Select video signal type: Select the signal type with the \uparrow and \downarrow buttons. Select NTSC, PAL SECAM, NTSC4.43, M-PAL, or N-PAL as appropriate for the input signal. Auto Adjust is valid at VIDEO/S-VIDEO input when AUTO is selected, and is then used for automatic selection of the signal type.</p> <p>* Use this function when the image becomes unstable (eg. the image becomes irregular, or lacks color).</p> <p>* Auto Adjust requires approximately ten seconds. It may not function correctly with some input signals. Pressing the AUTO button in this case may correct this problem.</p> |
| AUTO | <p>Automatic adjustment at RGB input: Select EXECUTE with the \rightarrow button. Horizontal position, vertical position, clock phase, and horizontal size are automatically adjusted when EXECUTE is selected. Use with the window at maximum size in the application display.</p> <p>Automatic adjustment at VIDEO/S-VIDEO input: Select EXECUTE with the \rightarrow button. A signal type appropriate for the input signal is selected automatically when EXECUTE is selected. Valid only if AUTO is selected in VIDEO (see above).</p> <p>* This operation requires approximately ten seconds. It may not function correctly with some input signals. Pressing the AUTO button in this case may correct this problem.</p> <p>* This function is the same as for Auto Adjust in Basic operation.</p> |



Discount-Merchant.com (800) 281-8860
THE TRUSTED SOURCE FOR PROJECTOR LAMPS AND ACCESSORIES

OPERATIONS (continued)

Image Menu

The following adjustments and settings are available when IMAGE is selected on the menu. Select an item with the ▲ and ▼ buttons, and start operation.

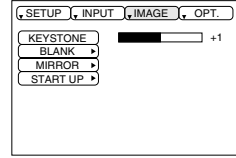

ENGLISH

Table 5. Image Menu

| Item | Description |
|----------|---|
| KEYSTONE | Adjustment: Reduce size of bottom of image ◀ ↔ Reduce size of top of image ▶ |
| BLANK | Select blank screen color: Select color with the ◀ and ▶ buttons. * The image is cleared when the BLANK mode is set with BLANK ON, or when there is no signal, and the entire screen is displayed in the selected color. Note that if TURN OFF is selected on the START UP the blank screen is displayed in blue when there is no signal. |
| MIRROR | Operation start/stop: Press the ▶ or ◀ button. Select Mirror status: Select mirror status with ▲ and ▼ buttons. |
| START UP | Operation start/stop: Press the ▶ or ◀ button. Setup initial screen display: Select TURN ON with the ▲ button. Clear initial screen display: Select TURN OFF with the ▼ button. * Note that if TURN OFF is selected the blank screen is displayed in blue when there is no signal. |



Discount-Merchant.com (800) 281-8860
THE TRUSTED SOURCE FOR PROJECTOR LAMPS AND ACCESSORIES

OPERATIONS (continued)

Options Menu

The following adjustments and settings are available when OPT. is selected on the menu. Select an item with the ▲ and ▼ buttons, and start operation.

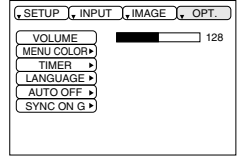

Table 6. Options Menu

| Item | Description |
|------------|--|
| VOLUME | Volume adjustment: Reduce VOLUME ◀ ↔ Increase VOLUME ▶ |
| MENU COLOR | Select menu background color: Select with the ▶ and ◀ buttons. |
| TIMER | Operation start/stop: Press the ▶ or ◀ button. Setup initial timer value: Set 1~99 minutes with the ▲ and ▼ buttons. |
| LANGUAGE | Operation start/stop: Press the ▶ or ◀ button. Select menu display language: Select with the ▲ and ▼ buttons. |
| AUTO OFF | Operation start/stop: Press the ▶ or ◀ button. Set AUTO OFF: Set 1~99 minutes with the ▲ and ▼ buttons. The system automatically enters the standby mode when a signal is not received for the set time. Clear AUTO OFF: Select STOP (0 min.) with the ▼ button. Wind Stop is selected the system does not enter the standby mode even if no signal is received. |
| SYNC ON G | Operation start/stop: Press the ▶ or ◀ button. SYNC ON G valid: Select TURN ON with the ▲ button. SYNC ON G invalid: Select TURN OFF with the ▼ button. * May not be displayed correctly with some input signals when SYNC ON G is valid. In such cases, remove the signal connector so that knows signal is received, set SYNC ON G to invalid, and reconnect the signal. |



Discount-Merchant.com (800) 281-8860
THE TRUSTED SOURCE FOR PROJECTOR LAMPS AND ACCESSORIES

OPERATIONS (continued)

No Signal Menu

The same adjustments and settings are available as with the Image and Options menus when the MENU button is pressed during display of the “NO INPUT IS DETECTED ON ***” or “SYNC IS OUT OF RANGE ON ***” message while no signal is received.

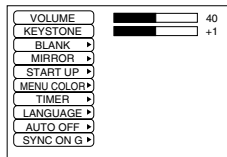

Table 7. No Signal Menu

| Item | Description |
|------------|--|
| VOLUME | Volume adjustment: Reduce VOLUME ◀ ↔ Increase VOLUME ▶ |
| KEYSTONE | Adjustment: Reduce size of bottom of image ◀ ↔ Reduce size of top of image ▶ |
| BLANK | Select blank screen color: Select color with the ◀ and ▶ buttons. * When the blank mode is set with BLANK ON, by absence of a signal, or by input of a non-standard signal, the image is cleared and the complete screen is displayed in the selected colour. Note that if No Display is selected in Initial Screen the blank screen is displayed in blue when no signal is received. |
| MIRROR | Operation start/stop: Press the ▶ or ◀ button. Select Mirror status: Select mirror status with ▲ and ▼ buttons. |
| START UP | Operation start/stop: Press the ▶ or ◀ button. Setup initial screen display: Select TURN ON with the ▲ button. Clear initial screen display: Select TURN OFF with the ▼ button. * Note that if TURN OFF is selected the blank screen is displayed in blue when there is no signal. |
| MENU COLOR | Select menu background color: Select with the ▶ and ◀ buttons. |
| TIMER | Operation start/stop: Press the ▶ or ◀ button. Setup initial timer value: Set 1~99 minutes with the ▲ and ▼ buttons. |
| LANGUAGE | Operation start/stop: Press the ▶ or ◀ button. Select menu display language: Select with the ▲ and ▼ buttons. |
| AUTO OFF | Operation start/stop: Press the ▶ or ◀ button. Set AUTO OFF: Set 1~99 minutes with the ▲ and ▼ buttons. The system automatically enters the standby mode when a signal is not received for the set time. Clear AUTO OFF: Select STOP (0 min.) with the ▼ button. When STOP is selected the system does not enter the standby mode even if no signal is received. |
| SYNC ON G | Operation start/stop: Press the ▶ or ◀ button. SYNC ON G valid: Select TURN ON with the ▲ button. SYNC ON G invalid: Select TURN OFF with the ▼ button. * May not be displayed correctly with some input signals when SYNC ON G is valid. In such cases, remove the signal connector so that knows signal is received, set SYNC ON G to invalid, and reconnect the signal. |

FixYourDLP.com
Sponsored by
Discount-Accessories.com (800) 281-8860
THE TRUSTED SOURCE FOR DLP AND ACCESSORIES

MAINTENANCE

Lamp



**HIGH VOLTAGE
HIGH TEMPERATURE
HIGH PRESSURE**

Contact your dealer before replacing the lamp.

(Option lamp: DT00301)

Before replacing the lamp, switch power OFF, remove the power cord from the power outlet, and wait approximately 45 minutes until the lamp has cooled. The lamp may explode if handled at high temperatures.

* For disposal of used lamp, treat according to the instruction of community authorities.

* Since the lamp is made of glass, do not apply shock to it and do not scratch it.

* Also, do not use old lamp. This could also cause explosion of the lamp.

* If it is probable that the lamp has exploded (explosive sound is heard), disconnect the power plug from the power outlet and ask your dealer to replace lamp.

The lamp is covered by front glass, but, in rare cases, the reflector and the inside of the projector may be damaged by scattered broken pieces of glass, and broken pieces could cause injury when being handled.

* Do not use the projector with the lamp cover removed.

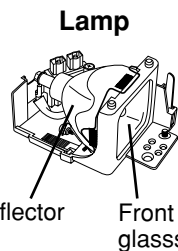

Lamp Life

Projector lamps have a finite life. The image will become darker, and hues will become weaker, after a lamp has been used for a long period of time.

Replace the lamp if the LAMP indicator is red, or the CHANGE THE LAMP message (see P.19 Table 8) appears when the projector is switched ON.



The LAMP is also red when the lamp unit reaches high temperature. Before replacing the lamp, switch power OFF, wait approximately 20 minutes, and switch power ON again. If the LAMP indicator is still red, replace the lamp.



Discount-Merchant.com (800) 281-8860
THE TRUSTED SOURCE FOR PROJECTOR LAMPS AND ACCESSORIES

Replacing the Lamp

1. Switch the projector OFF, remove the power cord from the power outlet, and wait at least 45 minutes for the unit to cool.
2. Prepare a new lamp.
3. Check that the projector has cooled sufficiently, and gently turn it upside down.
4. Loosen the two screws as shown in the diagram, and remove the lamp cover.
5. Loosen the one screw, and gently remove the lamp while holding the grips. Touching the inside of the lamp case may result in uneven coloring.
6. Install the new lamp and tighten the one screw firmly. Also steadily push the opposite side of the screwed lamp into the unit.
7. Replace the lamp cover in position and tighten the two screws firmly.
8. Gently turn the projector right-side up.

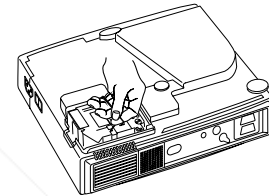
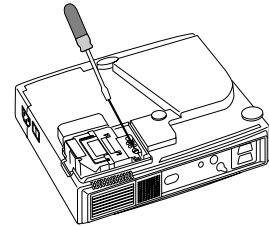
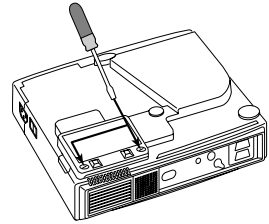





* Ensure that screws are tightened properly. Screws not tightened fully may result in injury or accidents.

* Do not use the projector with the lamp cover removed.

Resetting the Lamp Timer

Reset the lamp timer after replacing the lamp. When the lamp has been replaced after the LAMP indicator is red, or the CHANGE THE LAMP message is displayed, complete the following operation within ten minutes of switching power ON. The power will be turned off automatically in over 10 minutes.

1. Switch power ON, and press the TIMER button on the remote controller, or the RESET  button on the control panel, for approximately three seconds. The 'LAMP xxxx hr' message will appear on the lamp timer on the bottom of the screen.
2. Press the MENU button on the remote controller, or the RESET button on the control panel, while the lamp timer is displayed. The 'LAMP xxxx  → 0  CANCEL' message will then appear.
3. Press the  and select 0, and wait until the timer display is cleared.

FixYourDLP.com

Sponsored by 



Do not reset the lamp timer without replacing the lamp. Reset the lamp timer always when replace the lamp. The message functions will not operate properly if the lamp timer is not reset correctly.

MAINTENANCE (continued)

Air Filter Maintenance



Switch power OFF and remove the power cord from the power outlet before beginning maintenance work. Please read the separate “SAFETY INSTRUCTIONS” thoroughly to ensure that maintenance is performed correctly.

The air filter should be cleaned as described below at intervals of approximately 100 hours.

1. Switch the projector power supply OFF, and remove the power cord from the power outlet.
2. Clean the air filter with a vacuum cleaner.



- * Replace the air filter if contamination cannot be removed, or if it is damaged. Contact your dealer in such case.(Option Air filter : MU01291)
- * Do not use the equipment with the air filter removed.
- * When the air filter is clogged with dust etc. the CHECK AIR FLOW message appears on the screen and the power supply is switched OFF automatically to prevent the temperature rising inside the projector.

Other Maintenance



Switch power OFF and remove the power cord from the power outlet before beginning maintenance work. Please read the separate “SAFETY INSTRUCTIONS” thoroughly to ensure that maintenance is performed correctly.

Maintenance Inside the Equipment

For safety reasons, ensure that the equipment is cleaned and checked by the dealer once every two years. Maintaining the equipment by yourself is dangerous.

Cleaning the Lens

Gently wipe the lens with lens cleaning paper. Do not touch the lens with your hands.

Cleaning the Cabinet and Remote Controller

Gently wipe with a soft cloth. If dirt and stained etc. are not easily removed, use a soft cloth dampened with water, or water and a neutral detergent, and wipe dry with a soft, dry cloth.

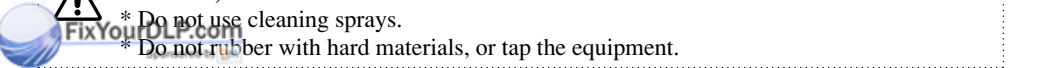

- * Do not use detergents or chemicals other than those noted above (e.g. benzene or thinners).
- * Do not use cleaning sprays.
- * Do not rub with hard materials, or tap the equipment.

 Discount-Merchant.com (800) 281-8860
THE TRUSTED SOURCE FOR PROJECTOR LAMPS AND ACCESSORIES

TROUBLESHOOTING

OSD Message

The messages as described below may appear on the screen at power ON. Take the appropriate measures when such a message appears.

Table 8. OSD Messages

| Message | Contents |
|--|--|
| CHANGE THE LAMP AFTER REPLACING LAMP, RESET THE LAMP TIME. *1) | The message shown at left appears after the lamp has been used for more than 1700 hours. The lamp is approaching the end of its life. Power is switched OFF automatically when the lamp reaches the end of its life. Prepare a new lamp for installation. Always reset the lamp timer after replacing the lamp. |
| CHANGE THE LAMP AFTER REPLACING LAMP, RESET THE LAMP TIME. THE POWER WILL TURN OFF AFTER ** hr. *1) | The lamp will reach the end of its life in ** hours. Power will be switched OFF automatically in ** hours. Replace the lamp as shown in P.16 "Lamp". Always reset the lamp timer after replacing the lamp. |
| CHANGE THE LAMP AFTER REPLACING LAMP, RESET THE LAMP TIME. THE POWER WILL TURN OFF AFTER 0 hr. | The lamp has reached the end of its life. Power will be switched OFF in a few moments. Switch power OFF immediately and replace the lamp as shown in P.16 "Lamp". Always reset the lamp timer after replacing the lamp. |
| NO INPUT IS DETECTED ON *** | No input signal found. Check signal input connections and signal sources. |
| SYNC IS OUT OF RANGE ON *** | The horizontal or vertical frequency of the input signal is not within the specified range. Check the specifications of the equipment and the signal source. |
| CHECK THE AIR FLOW FixYourDLP.com Sponsored by DMI | The internal temperature has risen. Switch power OFF, and wait 20 minutes until the equipment cools. Check the following and Switch power ON again. * Are the ventilation openings blocked. * Is the air filter dirty. * Is the ambient temperature in excess of 35°C. |



*1) This message is cleared automatically after approximately three minutes, and appears every time power is switched ON.

TROUBLESHOOTING (continued)

Indicators Message

The POWER indicator, LAMP indicator, and TEMP indicator are lit and blank as follows. Take the appropriate measures.

Table 9. Indicators Message

| POWER indicator | LAMP indicator | TEMP indicator | Contents |
|-----------------|----------------|----------------|--|
| Lights orange | Turns off | Turns off | The Standby mode has been set. |
| Blinks green | Turns off | Turns off | Warming up. Please wait. |
| Lights green | Turns off | Turns off | ON. Normal operation possible. |
| Blinks orange | Turns off | Turns off | Cooling. Please wait. |
| Lights red | Lights red | Turns off | Lamp is not lit. The interior of the equipment may be too hot. Switch power OFF, wait 20 minutes until the equipment cools, and Switch power ON again. Replace the lamp if the same problem occurs. |
| Lights red | Blinks red | Turns off | No lamp or lamp cover is found, or hasn't been fitted in correctly. Switch power OFF, and wait for 45 minutes until the equipment cools. Check fitting of the lamp and lamp cover, and switch power ON again. Contact your dealer if the same problem occurs again. |
| Lights red | Turns off | Blinks red | The cooling fan is not operating. Switch power OFF, and wait for 20 minutes until the equipment cools. Check for foreign matters in the fan, and switch power ON again. Contact your dealer if the same problem occurs again. |
| Lights red | Turns off | Lights red | The interior of the equipment is too hot. *1) Switch power OFF, and wait for 20 minutes until the equipment cools. Check whether the ventilation openings are blocked, whether the air filter is dirty, or whether the ambient temperature exceeds 35 °C. Then switch power ON again. Contact your dealer if the same problem occurs again. |





*1) When the internal temperature becomes excessive power is switched OFF automatically for safety reasons, and the indicator is extinguished. Set the power switch to [O] and wait for 20 minutes until the equipment has cooled sufficiently.

TROUBLESHOOTING (continued)

Symptom

Before requesting repair, check in accordance with the following chart. If the situation cannot be corrected, then contact your dealer.

Table 10. Symptom

| Symptom | Possible cause | Remedy | Page |
|---|--|--|-------|
| The power is not turned on. | The main power switch is not turned on. | Turn on the main power switch. | 6,8 |
| | The power cord is disconnected. | Plug the power cord into an AC power outlet. | |
| No video or audio. | The input is not correctly set. | Use the projector or remote control to set. | 9 |
| | No signal input. | Connect correctly. | 6,7 |
| Video is present but no audio. | The projector is not correctly connected. | Connect correctly. | 6,7 |
| | The volume is set to minimum. | Press VOLUME  on the remote control or display the menu screen and adjust the volume. | 10,14 |
| | Mute is turned on. | Press the MUTE  button. | 10 |
| Audio is present but no video. | The projector is not correctly connected. | Connect correctly. | 6,7 |
| | The brightness adjustment knob is rotated fully clockwise. | Select BRIGHT with the MENU button and then press the  button. | 11 |
| | The slide lens door is still closed. | Open the slide lens door. | 8 |
| Colors are pale and color matching is poor. | Color density and color matching are not correctly adjusted. | Adjust the video. | 11 |
| Images are dark. | Brightness and contrast are not correctly adjusted. | Adjust the video. | 11 |
| | The lamp is nearing the end of its service life. | Replace with a new lamp. | 16 |
| Video is blurred. | Focus or H PHASE is out of adjustment. | Adjust the focus or H PHASE. | 11 |





This product is supplied with a written warranty. Please read it thoroughly, enter the required details, and store in a safe place.

SPECIFICATIONS

NOTE : This specifications are subject to change without notice.

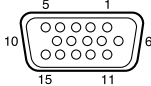
Table 11. Specifications

| Item | | Specification |
|----------------------|---------------------|--|
| Product name | | Liquid crystal projector |
| Model | | ULTRALIGHT S520 |
| Liquid crystal panel | Panel size | 1.8 cm (0.7 type) |
| | Drive system | TFT active matrix |
| | Pixels | 480,000 pixels (800 horizontal x 600 vertical) |
| Lens | | Zoom lens F=2.0 ~ 2.3 f=18 ~ 21 mm |
| Lamp | | 130 W UHB |
| Speaker | | 1.0 W |
| Power supply | | AC100 ~ 120V, 2.0A / AC220 ~ 240V, 0.9A |
| Power consumption | | 200 W |
| Temperature range | | 0 ~ 35°C (Operating) |
| Size | | 289 (W) x 76 (H) x 210 (D) mm |
| Weight (mass) | | 2.4 kg or less |
| INPUT signal | RGB | Video: Analog 0.7Vp-p, 75Ω terminator (positive) H/V. sync.: TTL level (positive/negative) Compound sync.: TTL level D-sub 15-pin shrink jack |
| | |  |
| | | 7 Ground Green |
| | | 8 Ground Blue |
| | | 9 - |
| | | 10 Ground |
| | | 11 - |
| | 1 Video input Red | 12 DDC jack |
| | 2 Video input Green | 13 H. sync./ Compound sync. |
| | 3 Video input Blue | 14 Vertical sync |
| 4 - | 15 DDC jack | |
| | VIDEO | 1.0Vp-p, 75Ω terminator, RCA jack |
| | S-VIDEO | Mini DIN 4-pin jack |
| | |  |
| | AUDIO | 200mVrms, 47 kΩ or less (max. 3.0Vp-p) Stereo mini jack (Speaker output is L/R mixed.) |
| CONTROL signal | | D-sub 15-pin shrink jack |

SPECIFICATIONS (continued)

Dimension Diagram

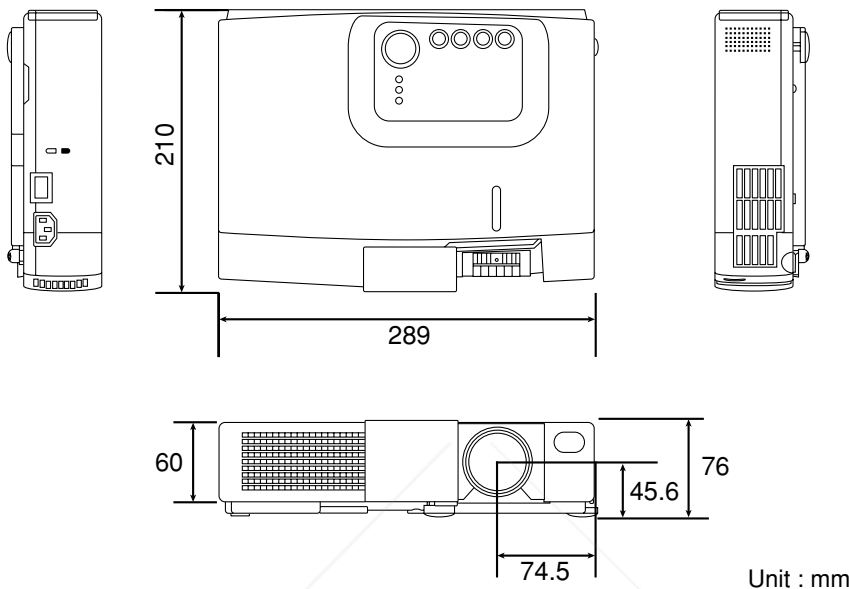

ENGLISH

WARRANTY AND AFTER-SERVICE



This product is supplied with a written warranty. Please read it thoroughly, enter the required details, and storage in a safe place.

* If a problem occurs with the equipment, first refer to the P.19 “TROUBLESHOOTING” section and run through the suggested checks. If this does not resolve the problem contact your dealer or service company. If repairs are possible, and desirable, they will be charged.



Discount-Merchant.com (800) 281-8860
THE TRUSTED SOURCE FOR PROJECTOR LAMPS AND ACCESSORIES

REGULATORY NOTICES

FCC Statement Warning

WARNING: This equipment has been tested and found to comply with the limits for a Class B digital device, pursuant to Part 15 of the FCC Rules. These limits are designed to provide reasonable protection against harmful interference in a residential installation. This equipment generates, uses, and can radiate radio frequency energy and, if not installed and used in accordance with the instructions, may cause harmful interference to radio communications. However, there is no guarantee that interference will not occur in a particular installation. If this equipment does cause harmful interference to radio or television reception, which can be determined by turning the equipment off and on, the user is encouraged to try to correct the interference by one or more of the following measures:

- Reorient or relocate the receiving antenna.
- Increase the separation between the equipment and receiver.
- Connect the equipment into an outlet on a circuit different from that to which the receiver is connected.
- Consult the dealer or an experienced radio/TV technician for help.

INSTRUCTIONS TO USERS: This equipment complies with the requirements of FCC (Federal Communication Commission) equipments provided that following conditions are met.

The cables (Power cord, RGB cable and other cables) may have to be used with the core set to the projector side. Use the cables which are included with the projector or specified.

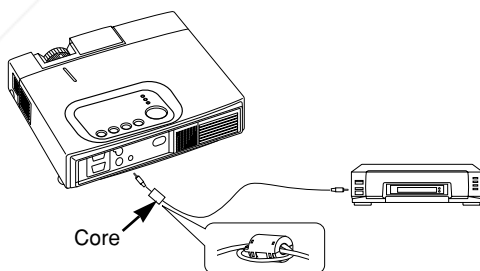

CAUTION: Changes or modifications not expressly approved by the party responsible for compliance could void the user's authority to operate the equipment.

For the Customers in CANADA

NOTICE: This Class B digital apparatus complies with Canadian ICES-003.

Table 1. Example of computer signal

| Resolution H × V | fH (kHz) | fV (Hz) | Rating | Signal mode | Display mode | Note 1 |
|---------------------|----------|---------|--------|-------------|--------------|--------------------|
| 640 × 350 | 37.9 | 85.1 | VESA | VGA-1 | Zoom in | |
| 640 × 400 | 37.9 | 85.1 | VESA | VGA-2 | Zoom in | |
| 720 × 400 | 37.9 | 85.0 | VESA | TEXT | Zoom in | |
| 640 × 480 | 31.5 | 59.9 | VESA | VGA-3 | Zoom in | |
| 640 × 480 | 35.0 | 66.7 | | Mac13"mode | Zoom in | SW 1 ON SW 2 ON |
| 640 × 480 | 37.9 | 72.8 | VESA | VGA-3(72Hz) | Zoom in | |
| 640 × 480 | 37.5 | 75.0 | VESA | VGA-3(75Hz) | Zoom in | |
| 640 × 480 | 43.3 | 85.0 | VESA | VGA-3(85Hz) | Zoom in | |
| 800 × 600 | 35.2 | 56.3 | VESA | SVGA(56Hz) | | |
| 800 × 600 | 37.9 | 60.3 | VESA | SVGA(60Hz) | | |
| 800 × 600 | 48.1 | 72.2 | VESA | SVGA(72Hz) | | |
| 800 × 600 | 46.9 | 75.0 | VESA | SVGA(75Hz) | | |
| 800 × 600 | 53.7 | 85.1 | VESA | SVGA(85Hz) | | |
| 832 × 624 | 49.7 | 74.5 | | Mac16"mode | Zoom out | SW 2 ON SW 4 ON |
| 1024 × 768 | 48.4 | 60.0 | VESA | XGA(60Hz) | Zoom out | |
| 1024 × 768 | 56.5 | 70.1 | VESA | XGA(70Hz) | Zoom out | |
| 1024 × 768 | 60.0 | 75.0 | VESA | XGA(75Hz) | Zoom out | |

Note 1: Mac adapter is necessary to the resolution mode.
 Projector is compatible with 13 inch mode and 16 inch mode.
 Mac 13" mode=switch 1 and switch 2 are ON.
 Mac 16" mode=switch 2 and switch 4 are ON.

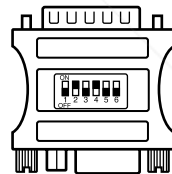

(Example 16 inch mode)

Caution • Some computers may have multiple display screen modes. Use of some of these modes will not be possible with this projector.
 • Be sure to check jack type, signal level, timing and resolution before connecting this projector to a computer.
 • Depending on the input signal, full-size display may not be possible in some cases. Refer to the number of display pixels above.

Table 2. Initial set signals

The following signals are used for the initial settings.

The signal timing of some computer models may be different. In such case, refer to adjust the V.POSIT and H.POSIT of the menu.

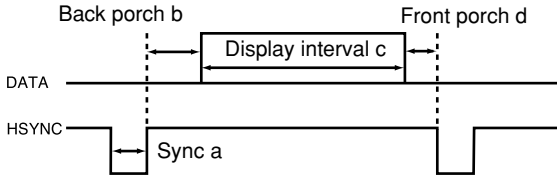

| Computer / Signal | Horizontal signal timing (µs) | | | |
|-------------------|-------------------------------|-----|------|-----|
| | a | b | c | d |
| VGA-1(85Hz) | 2.0 | 3.0 | 20.3 | 1.0 |
| VGA-2(85Hz) | 2.0 | 3.0 | 20.3 | 1.0 |
| TEXT | 2.0 | 3.0 | 20.3 | 1.0 |
| VGA-3 | 3.8 | 1.9 | 25.4 | 0.6 |
| Mac 13"mode | 2.1 | 3.2 | 21.2 | 2.1 |
| VGA-3(72Hz) | 1.3 | 3.8 | 20.3 | 1.0 |
| VGA-3(75Hz) | 2.0 | 3.8 | 20.3 | 0.5 |
| VGA-3(85Hz) | 1.6 | 2.2 | 17.8 | 1.6 |

| Computer / Signal | Horizontal signal timing (µs) | | | |
|-------------------|-------------------------------|-----|------|-----|
| | a | b | c | d |
| SVGA(56Hz) | 2.0 | 3.6 | 22.2 | 0.7 |
| SVGA(60Hz) | 3.2 | 2.2 | 20.0 | 1.0 |
| SVGA (72Hz) | 2.4 | 1.3 | 16.0 | 1.1 |
| SVGA (75Hz) | 1.6 | 3.2 | 16.2 | 0.3 |
| SVGA (85Hz) | 1.1 | 2.7 | 14.2 | 0.6 |
| Mac 16"mode | 1.1 | 3.9 | 14.5 | 0.6 |
| XGA (60Hz) | 2.1 | 2.5 | 15.8 | 0.4 |
| XGA (70Hz) | 1.8 | 1.9 | 13.7 | 0.3 |
| XGA (75Hz) | 1.2 | 2.2 | 13.0 | 0.2 |

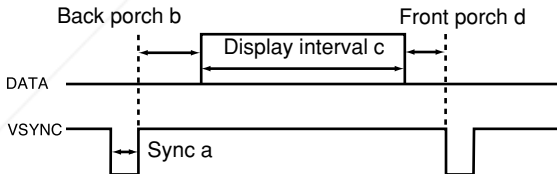

| Computer / Signal | Vertical signal timing (lines) | | | |
|-------------------|--------------------------------|----|-----|----|
| | a | b | c | d |
| VGA-1(85Hz) | 3 | 60 | 350 | 32 |
| VGA-2(85Hz) | 3 | 41 | 400 | 1 |
| TEXT | 3 | 42 | 480 | 1 |
| VGA-3 | 2 | 33 | 480 | 10 |
| Mac 13"mode | 3 | 39 | 480 | 3 |
| VGA-3(72Hz) | 3 | 28 | 480 | 9 |
| VGA-3(75Hz) | 3 | 16 | 480 | 1 |
| VGA-3(85Hz) | 3 | 25 | 480 | 1 |

| Computer / Signal | Vertical signal timing (lines) | | | |
|-------------------|--------------------------------|----|-----|----|
| | a | b | c | d |
| SVGA(56Hz) | 2 | 22 | 600 | 1 |
| SVGA(60Hz) | 4 | 23 | 600 | 1 |
| SVGA (72Hz) | 6 | 23 | 600 | 37 |
| SVGA (75Hz) | 3 | 21 | 600 | 1 |
| SVGA (85Hz) | 3 | 27 | 600 | 1 |
| Mac 16"mode | 3 | 39 | 624 | 1 |
| XGA (60Hz) | 6 | 29 | 768 | 3 |
| XGA (70Hz) | 6 | 29 | 768 | 3 |
| XGA (75Hz) | 3 | 28 | 768 | 1 |

Liquid Crystal Projector

SAFETY INSTRUCTIONS

USER'S MANUAL – Separate Volume

Before using this product, please read and understand the Safety Instructions thoroughly to ensure correct usage.

After reading, store the Safety Instructions together with the USER'S MANUAL.

SICHERHEITSVORSCHRIFTEN

BEDIENUNGSANLEITUNG – Andere Band

Bevor Sie dieses Produkt benutzen, sollten Sie die Sicherheitsvorschriften gründlich durchlesen und sich mit ihnen vertraut machen, um korrekten Gebrauch zu gewährleisten. Bewahren Sie die Sicherheitsvorschriften nach dem Durchlesen zusammen mit der BEDIENUNGSANLEITUNG auf.

CONSIGNES DE SÉCURITÉ

MANUEL D'UTILISATION – Volume Annexe

Avant d'utiliser ce produit, veuillez lire attentivement les consignes de sécurité afin d'utiliser l'appareil dans les meilleures conditions. Une fois que vous avez terminé, rangez les Consignes de sécurité avec le MANUEL D'UTILISATION.

ISTRUZIONI DI SICUREZZA

MANUAL D'ISTRUZIONI – Volume Separato

Prima di usare questo prodotto, leggere attentamente ed assimilare le istruzioni di sicurezza per garantire un corretto uso dello stesso. Dopo averle lette riporre le istruzioni di sicurezza con il MANUALE D'ISTRUZIONI.

INSTRUCCIONES DE SEURIDAD

MANUAL DE USUARIO – Volumen Separdo

Antes de usar este producto, se recomienda leer y comprender cabalmente todas las instrucciones de seguridad para poderlo utilizar correctamente. Después de leer las instrucciones de seguridad, guárdelas junto con el MANUAL DE USUARIO.

VEILIGHEIDSINSTRUCTIES

GEBRUIKSAANWIJZNG – Afzonder Band

Lees voor gebruik de Veiligheidsinstructies aandachtig door zodat u het apparaat op de juiste wijze behandelt. Bewaar de Veiligheidsinstructies samen met de GEBRUIKSAANWIJZNG voor het geval u deze in de toekomst nogmaals nodig hebt.

SIKKERHETSINSTRUKSJONER

BRUKERHÅNDBOK – Separate Håndbok

Før dette produktet tas i bruk, må "Sikkerhetsregler" til fulle leses og forstås for å sikre korrekt bruk. Etterpå må de oppbevares sammen med BRUKERHÅNDBOK.

INSTRUÇÕES DE SEGURANÇA

INSTRUÇÕES DO PROPRIETÁRIO – Folheto à Parte

Antes de usar este produto, leia atentamente as Instruções de Segurança para assegurar o uso correto do equipamento. Após a leitura, guarde as Instruções de Segurança juntamente com o INSTRUÇÕES DO PROPRIETÁRIO.

ENGLISH

DEUTSCH

FRANÇAIS

ITALIANO

ESPAÑOL

NEDERLANDS

NORASK

PORTGÊS



Dropin.com (800) 881-886

THE TRUSTED SOURCE FOR PROJECTOR LAMPS AND ACCESSORIES





Discount-Merchant.com (800) 281-8860
THE TRUSTED SOURCE FOR PROJECTOR LAMPS AND ACCESSORIES

BEFORE USING

About the Symbols

Various symbols are used in this manual, the user's manual and on the product itself to ensure correct usage, to prevent danger to the user and others, and to prevent property damage. The meanings of these symbols are described below. It is important that you read these descriptions thoroughly and fully understand the contents.

| | |
|--|--|
|  Warning | This symbol indicates information that, if ignored, could possibly result in personal injury or even death due to incorrect handling. |
|  Caution | This symbol indicates information that, if ignored, could result possibly in personal injury or physical damage due to incorrect handling. |

Typical Symbols



This symbol indicates an additional warning (including cautions). An illustration is provided to clarify the contents.



This symbol indicates a prohibited action. The contents will be clearly indicated in an illustration or nearby (the symbol to the left indicates that disassembly is prohibited).



This symbol indicates a compulsory action. The contents will be clearly indicated in an illustration or nearby (the symbol to the left indicates that the power plug should be disconnected from the power outlet).



Discount-Merchant.com (800) 281-8860
THE TRUSTED SOURCE FOR PROJECTOR LAMPS AND ACCESSORIES

SAFETY PRECAUTIONS

WARNING

Never use the projector if a problem should occur.

Abnormal operations such as smoke, strange odor, no image, no sound, excessive sound, damaged casing or elements or cables, penetration of liquids or foreign matter, etc. can cause a fire or electrical shock.

In such case, immediately turn off the power switch and then disconnect the power plug from the power outlet. After making sure that the smoke or odor has stopped, contact your dealer. Never attempt to make repairs yourself because this is dangerous this could be dangerous.

* The power outlet should be close to the projector and easily accessible.



Disconnect the plug from the power outlet.

Do not insert liquids or foreign object.

Penetration of liquids or foreign objects could result in fire or electrical shock.

Use special caution in households where children are present.

If liquids or foreign object should enter the projector, immediately turn off the power switch, disconnect the power plug from the power outlet and contact your dealer.

* Do not place the projector in a bathroom.

* Do not expose the projector to rain or moisture.

* Do not place flower vases, pots, cups, cosmetics, liquids such as water, etc on or around the projector.

* Do not place metals, combustibles, etc on or around the projector.



Never modify.

The projector contains high voltage components. Modification could result in fire or electrical shock.

* Never open the cabinet.

* Ask your dealer to repair and clean insides.



Do not disassemble.

Do not give the projector any shock or impact.

If the projector should be shocked and/or broken, it could result in an injury, and continued use could result in fire or electrical shock.

If the projector is shocked, immediately turn off the power switch, disconnect the power plug from the power outlet and contact your dealer.



Discount-Merchant.com (800) 281-8860
THE TRUSTED SOURCE FOR PROJECTOR LAMPS AND ACCESSORIES

SAFETY PRECAUTIONS (continued)

WARNING

Do not place the projector on an unstable surface.

If the projector should be dropped and/or broken, it could result in an injury, and continued use could result in fire or electrical shock.

- * Do not place the projector on an unstable, slant or vibrant surface such as a wobbly or inclined stand.
- * Use the caster brakes placing the projector on a stand with casters.
- * Do not place the projector in the side up position, the lens up position or the lens down position.



ENGLISH

Be cautious of High temperatures of the projector.

High temperatures are generated when the lamp is lit. It could result in fire or burn. Use special caution in households where children are present.

Do not touch about the lens, air fans and ventilation openings during use or immediately after use, to prevent a burn. Take care of ventilation.

- * Keep a space of 30 cm or more between the sides and other objects such as walls.
- * Do not place the projector on the metallic table.
- * Do not place anything about the lens, air fans and ventilation openings of the projector.
- * Never block the air fan and ventilation openings.
- * Do not use with the ventilation opening facing downwards.
- * Do not cover the projector with a tablecloth, etc.
- * Do not place the projector on a carpet or bedding.



Never look through the lens or openings when the lamp is on.

The powerful light could adversely affect vision. Use special caution in households where children are present.



Use only the correct power outlet.

Incorrect power supply could result in fire or electrical shock. Use only the correct power outlet depending on the indication on the projector and the safety standard.

- * The enclosed power cord must be used depending on the power outlet to be used.



Be cautious of the power cord connection.

Incorrect connection of the power cord could result in fire or electrical shock.

- * Do not touch the power cord with a wet hand.
- * Check that the connecting portion of the power cord is clean (with no dust), before using. Use a soft and dry cloth to clean the power plug.
- * Insert the power plug into a power outlet firmly. Avoid using a loose, unsound outlet or contact failure.



SAFETY PRECAUTIONS (continued)

WARNING

Be careful in handling the the light source lamp.

Incorrect handling the lamp could result in explosion.

- * Since the lamp is made of glass, do not apply shock to it and not scratch it.
- * When replacing lamp, turn off and remove AC cord, waite 45 minutes to let lamp cool. High-pressure lamp when hot, may explode if improperly handled.
- * The lamp has a service life. For details, read the user's manual. Please contact your dealer or service company for replacement. Do not use old use old lamp. This could also cause explosion of the lamp.



Be careful in handling the power cord and external connection cables.

If you keep using a damaged the power cord or cables, it can cause a fire or electrical shock. Do not apply too much heat, pressure or tension to the power cord and cables.

If the power cord or cables is damaged (exposed or broken core wires, etc.), contact your dealer.

- * Do not place the projector or heavy objects on the power cord and cables. Also, do not place a spread, cover, etc, over them because this could result in the inadvertent placing of heavy objects on the concealed power cord or cables.
- * Do not pull the power cord and cables. When connecting and disconnecting the power cord or cables, do it with your hand holding the plug or connector.
- * Do not place the cord near the heater.
- * Avoid bending the power cord sharply.
- * Do not attempt to work on the power cord.



Be careful in handling the battery of the remote controller.

Incorrect handling of the battery could result in fire or personal injury. The battery may explode if not handled properly.

- * Keep the battery away from children and pets. If swallowed consult a physician immediately for emergency treatment.
- * Do not allow the battery in a fire or water.
- * Avoid fire or high-temperature environment.
- * Do not hold the battery with the metallic tweezers.
- * Keep the battery in a dark, cool and dry play.
- * Do not short circuit the battery.
- * Do not recharge, disassemble or solder the battery.
- * Do not give the battery a physical impact.
- * Use only the battery specified in the user's manual.
- * Make sure the plus and minus terminals are correctly aligned when loading the battery.
- * If you observe a leakage of the battery, wipe out the flower and then replace the battery. If the flower adheres your body or clothes, rinse well with water.
- * Obey the local laws on disposing the battery.



SAFETY PRECAUTIONS (continued)

CAUTION

Be careful in moving the projector.

Neglect could result in an injury or damage.

- * Do not move the projector during use. Before moving, disconnect the power cord and all external connections, and close the slide lens door.
- * Avoid any impact or shock to the projector.
- * For carrying, use the enclosed carrying bag if provided, depending on the manual of the carrying bag.



ENGLISH

Do not put anything on top of the projector.

Placing anything on the projector could result in loss of balance or falling, and cause an injury or damage. Use special caution in households where children are present.



Avoid a humid or dusty place.

Placing the projector in a highly humid, dusty place, oily soot or corrosive gas could result in fire or electrical shock.

- * Do not place near the kitchen, a humidifier or other place where there is oily smoke or humidity.



Avoid a high temperature environment.

The heat could have adverse influence on the cabinet of the projector and other parts. Do not place the projector, the remote controller and other parts in direct sunlight or near a hot object such as heater, etc.



Remove the power cord for complete separation.

- * For safety purposes, disconnect the power cord if the projector is not to be used for prolonged periods of time.
- * Before cleaning, turn off and unplug the projector. Neglect could result in fire or electrical shock.



Disconnect the plug from the power outlet.

Ask your dealer to cleaning inside of the projector about every two years.

Accumulations of dust inside the projector cause result in fire or malfunction. Cleaning inside is more effective if performed before every humid periods such



rainy season.

Do not clean inside yourself because it is dangerous.

 Discount-Merchant.com (800) 281-8860
THE TRUSTED SOURCE FOR PROJECTOR LAMPS AND ACCESSORIES

SAFETY PRECAUTIONS (continued)

NOTE

Do not give the remote controller any physical impact.

A physical impact could cause damage or malfunction of the remote controller.

- * Take care not to drop the remote controller.
- * Do not place the projector or heavy objects on the remote controller.

Take care of the lens.

- * Close the slide lens door to prevent the lens surface being scratched when the projector is not used.
- * Do not touch the lens to prevent fog or dirt of the lens that cause deterioration of display quality.
- * Use commercially available lens tissue to clean the lens (used to clean cameras, eyeglasses, etc.). Be careful not to scratch the lens with hard objects.

Clean the air filter about every 100 hours.

When the air filter becomes clogged with dust, etc., the projector may display the message such as “CHECK THE AIR FLOW” or turn off the projector, to prevent the internal heat level rising. Take care of the air filter to normal ventilate.

- * Do not turn on the projector without air filter.
- * If the air filter is damaged or lost, order the air filter specified in the user’s manual to your dealer.

Take care of the cabinet and the remote controller.

Incorrect care could have adverse influence such as discoloration, peeling paint, etc.

- * Use a soft cloth to clean the cabinet and control panel of the projector and the remote controller. When excessively soiled dilute a neutral detergent in water, wet and wring out the soft cloth and afterward wipe with a dry soft cloth. Do not use undiluted detergent directly.
- * Do not use an aerosol sprays, solvents, volatile substances or abrasive cleaner.
- * Before using chemical wipes, be sure to read and observe the instructions.
- * Do not allow long-term close contact with rubber or vinyl.



Discount-Merchant.com (800) 281-8860
THE TRUSTED SOURCE FOR PROJECTOR LAMPS AND ACCESSORIES

SAFETY PRECAUTIONS (continued)

NOTE

Avoid strong rays.

Any strong ray (such as direct rays of the sun or room lighting) onto the remote control sensors could invalidate the remote control.

Avoid radio interference.

Any interfering radiation could cause disordered image or noises.

* Avoid radio generator such as a mobile telephone, transceiver, etc. around the projector.

About displaying characteristic.

The display condition of the projector (such as color, contrast, etc.) depends on characteristic of the screen, because the projector uses a liquid crystal display panel. The display condition can differ from the display of CRT.

* Do not use a polarized screen. It can cause red image.

Turn the power on/off in right order.

To prevent any trouble, turn on/off the projector in right order mentioned below unless specifying.

* Power on the projector before the computer or video tape recorder.

* Power off the projector after the computer or video tape recorder.

Take care not to fatigue your eyes.

Rest the eyes periodically.

Set the sound volume at a suitable level to avoid bothering other people.

* It is better to keep the volume level low and close the windows at night to protect the neighborhood environment.

Connecting with notebook computer



When connecting with notebook computer, set to valid the RGB external image output (setting CRT display or simultaneous display of LCD and CRT).

Please read instruction manual of the notebook for more information.

VOR DEM BETRIEB

Bedeutung der Symbole

Zugunsten der korrekten Bedienung des Geräts befinden sich in dieser Anleitung sowie auf dem Projektor selbst bestimmte Symbole, die auf Sicherheitsrisiken und entsprechende Vorsichtsmaßnahmen hinweisen, um Körperverletzungen und Sachschäden zu vermeiden. Die Bedeutung dieser Symbole ist nachfolgend erklärt. Es ist wichtig, daß Sie die folgenden Sicherheitshinweise aufmerksam durchlesen und verstehen.

| | | |
|---|-----------------|--|
|  | WARNUNG | Dieses Symbol weist auf Vorsichtsmaßnahmen hin, deren Mißachtung bei falscher Bedienung zu körperlichen Verletzungen mit möglicher Todesfolge führen können. |
|  | VORSICHT | Dieses Symbol weist auf Vorsichtsmaßnahmen hin, deren Mißachtung bei falscher Bedienung zu Personenverletzungen oder Sachschäden führen können. |

Typische Symbole



Dieses Symbol weist auf eine zusätzliche Warnung (einschließlich Vorsichtsmaßnahmen) hin, wobei eine Abbildung den Textinhalt verdeutlicht.



Dieses Symbol weist auf eine unzulässige Handlung hin, wobei eine Abbildung den Textinhalt verdeutlicht. (Das linksstehende Symbol bedeutet, daß das Gerät oder eine bestimmte Baugruppe nicht zerlegt werden darf.)



Dieses Symbol weist auf eine Pflichthandlung hin, wobei eine Abbildung den Textinhalt verdeutlicht. (Das linksstehende Symbol bedeutet, daß der Netzstecker aus der Steckdose zu ziehen ist.)



Discount-Merchant.com (800) 281-8860
THE TRUSTED SOURCE FOR PROJECTOR LAMPS AND ACCESSORIES

SICHERHEITSVORKEHRUNGEN

WARNUNG

Im Falle einer Störung den Projektor niemals weiterbenutzen.

Anormale Erscheinungen, wie Rauch, seltsamer Geruch, kein Bild, kein Ton, zu lauter Ton, Beschädigung von Gehäuse, Elementen oder Kabeln, Eindringen von Flüssigkeiten oder Fremdkörpern usw., können einen Brand oder elektrischen Schlag verursachen.

In solchen Fällen sofort den Netzschalter ausschalten, und dann den Netzstecker von der Netzsteckdose abziehen. Wenden Sie sich an Ihren Händler, nachdem Sie sich vergewissert haben, dass die Rauch- oder Gerucherzeugung aufgehört hat. Versuchen Sie niemals, Reparaturen selbst durchzuführen, weil das gefährlich sein kann.

* Die Netzsteckdose sollte sich in der Nähe des Projektors befinden und leicht zugänglich sein.



Den Netzstecker aus der Steckdose ziehen.

DEUTSCH

Das Eindringen von Flüssigkeiten oder Fremdkörper in den Projektor verhüten.

Das Eindringen von Flüssigkeiten oder Fremdkörpern kann einen Brand oder elektrischen Schlag verursachen.

Lassen Sie in Haushalten mit Kindern besondere Vorsicht walten.

Falls Flüssigkeiten oder Fremdkörper in den Projektor eindringen, schalten Sie sofort den Netzschalter aus, ziehen Sie den Netzstecker von der Netzsteckdose ab, und kontaktieren Sie Ihren Händler.

* Den Projektor nicht in ein Badezimmer stellen.

* Den Projektor weder Regen noch Feuchtigkeit aussetzen.

* Keine Blumenvasen, Töpfe, Tassen, Kosmetika oder Flüssigkeiten, wie z.B. Wasser usw., auf oder neben den Projektor stellen.

* Keine metallischen oder brennbaren Gegenstände usw. auf oder neben den Projektor stellen.



Keine Veränderungen vornehmen.

Der Projektor enthält unter Hochspannung stehende Teile. Eine Veränderung könnte zu einem Brand oder elektrischen Schlag führen.

* Niemals das Gehäuse öffnen.

* Lassen Sie Reparaturen und Reinigung der Innenteile nur von Ihrem Händler ausführen.



Nicht zerlegen.

 FixYourDLP.com

Den Projektor vor Stößen oder Erschütterungen schützen.

Falls der Projektor erschüttert und/oder beschädigt wird, kann es zu einer Verletzung kommen, und fortgesetzter Gebrauch kann einen Brand oder elektrischen Schlag zur Folge haben.

Falls der Projektor erschüttert wird, schalten Sie sofort den Netzschalter aus, ziehen Sie den Netzstecker von der Netzsteckdose ab, und kontaktieren Sie Ihren Händler.



WARNUNG

Stellen Sie den Projektor nicht auf eine instabile Fläche.

Falls der Projektor fallen gelassen und/oder beschädigt wird, kann es zu einer Verletzung kommen, und fortgesetzter Gebrauch kann einen Brand oder elektrischen Schlag zur Folge haben.

- * Stellen Sie den Projektor nicht auf eine instabile, schiefe oder vibrierende Fläche, wie z.B. einen wackligen oder geneigten Ständer.
- * Benutzen Sie die Laufrollenbremsen, wenn Sie den Projektor auf einen Ständer mit Laufrollen stellen.
- * Den Projektor nicht mit der Seite nach oben, dem Objektiv nach oben oder dem Objektiv nach unten hinstellen.



Beachten Sie hohe Temperaturen des Projektors.

Bei eingeschalteter Lampe werden hohe Temperaturen erzeugt. Diese können einen Brand oder Verbrennungen verursachen. Lassen Sie in Haushalten mit Kindern besondere Vorsicht walten.

Vermeiden Sie eine Berührung des Objektivs, der Lüfter und der Ventilationsöffnungen während oder unmittelbar nach dem Gebrauch, um eine Verbrennung zu verhüten. Achten Sie auf die Ventilation.

- * Einen Abstand von mindestens 30 cm zwischen dem Projektor und anderen Objekten, wie z.B. Wänden, einhalten.
- * Den Projektor nicht auf einen Metalltisch stellen.
- * Keine Gegenstände in der Nähe des Objektivs, der Lüfter und der Ventilationsöffnungen des Projektors abstellen.
- * Niemals die Lüfter und die Ventilationsöffnungen blockieren.
- * Nicht mit der Ventilationsöffnung nach unten verwenden.
- * Den Projektor nicht mit einer Tischdecke usw. abdecken.
- * Den Projektor nicht auf einen Teppich oder Bettzeug stellen.



Bei eingeschalteter Lampe niemals in das Objektiv oder die Öffnungen blicken.

Das starke Licht kann die Sehkraft beeinträchtigen. Lassen Sie in Haushalten mit Kindern besondere Vorsicht walten.



Nur eine vorschriftsmäßige Netzsteckdose verwenden.

Eine falsche Stromversorgung kann einen Brand oder elektrischen Schlag verursachen. Verwenden Sie eine korrekte Netzsteckdose gemäß den Angaben am Projektor und in den Sicherheitsvorschriften.

Das mitgelieferte Netzkabel muss in Übereinstimmung mit der vorhandenen Netzsteckdose verwendet werden.



Beim Umgang mit dem Netzkabel Vorsicht walten lassen.

Falscher Anschluss des Netzkabels kann einen Brand oder elektrischen Schlag verursachen.

- * Das Netzkabel nicht mit nassen Händen berühren.
- * Vergewissern Sie sich vor dem Anschließen, dass der Stecker des Netzkabels sauber ist (kein Staub). Verwenden Sie ein weiches und trockenes Tuch zum Reinigen des Netzsteckers.
- * Den Netzstecker bis zum Anschlag in die Netzsteckdose einführen. Eine lockere, nicht intakte Netzsteckdose oder Wackelkontakt vermeiden.



WARNUNG

Die Lichtquellenlampe vorsichtig handhaben.

Falsche Handhabung der Lampe kann zu Explosion führen.

- * Da die Lampe aus Glas ist, müssen Stöße und Kratzer vermieden werden.
- * Zum Auswechseln der Lampe den Projektor ausschalten, das Netzkabel abtrennen, und 45 Minuten zum Abkühlen der Lampe warten. Die Lampe erreicht beim Betrieb einen hohen Druck und kann bei falscher Handhabung explodieren.
- * Die Lampe hat eine begrenzte Verwendungsdauer. Beziehen Sie sich für Einzelheiten auf die Bedienungsanleitung. Bitte wenden Sie sich für Auswechseln der Lampe an Ihren Händler oder an eine Wartungsfirma. Verwenden Sie nicht eine alte Lampe. Dies kann auch eine Explosion der Lampe verursachen.



DEUTSCH

Netzkabel und externe Anschlusskabel sorgfältig behandeln.

Fortgesetzter Gebrauch eines beschädigten Netzkabels oder beschädigter Anschlusskabel kann einen Brand oder elektrischen Schlag verursachen. Netzkabel und Anschlusskabel vor übermäßiger Hitze, Druck oder Spannung schützen. Falls das Netzkabel oder die Anschlusskabel beschädigt sind (freiliegende oder gerissene Kernadern usw.), kontaktieren Sie Ihren Händler.

- * Stellen Sie nicht den Projektor oder andere schwere Gegenstände auf das Netzkabel und die Anschlusskabel. Decken Sie die Kabel auch nicht mit einem Tuch oder einer Decke usw. ab, weil sonst versehentlich schwere Gegenstände auf die verdeckten Kabel gestellt werden können.
- * Nicht am Netzkabel und den Anschlusskabeln ziehen. Halten Sie beim Anschließen und Abziehen des Netzkabels oder der Anschlusskabel stets den Kabelstecker mit der Hand.
- * Die Kabel nicht in der Nähe eines Heizkörpers verlegen.
- * Starkes Knicken des Netzkabels vermeiden.
- * Unterlassen Sie jede Abänderung des Netzkabels.



Die Batterie der Fernbedienung sorgfältig behandeln.

Falsche Behandlung der Batterie kann einen Brand oder Verletzungen zur Folge haben. Bei unsachgemäßer Behandlung kann die Batterie explodieren.

- * Die Batterie von Kindern und Haustieren fernhalten. Falls die Batterie verschluckt wird, wenden Sie sich zwecks einer Notbehandlung sofort an einen Arzt.
- * Die Batterie nicht in Feuer oder Wasser werfen.
- * Feuer oder heiße Umgebungen vermeiden.
- * Die Batterie nicht mit einer Metallpinzette halten.
- * Die Batterie an einem dunklen, kühlen und trockenen Ort aufbewahren.
- * Die Batterie nicht kurzschließen.
- * Die Batterie nicht aufladen, zerlegen oder löten.
- * Die Batterie vor Erschütterungen schützen.
- * Nur die im Bedienungsanleitung angegebene Batterie verwenden.
- * Achten Sie beim Einlegen der Batterie darauf, dass Plus- und Minuspol der Batterie korrekt ausgerichtet sind.
- * Falls Sie Auslaufen der Batterie feststellen, wischen Sie erst das Batteriefach aus und dann die Batterie ab.
Falls Elektrolyt mit irgendwelchen Körperteilen oder Kleidung in Berührung kommt, waschen Sie ihn mit Wasser gut ab.
- * Entsorgen Sie die Batterie gemäß den örtlichen Gesetzen.



VORSICHT

Beim Transportieren des Projektors Sorgfalt walten lassen.

Missachtung kann zu Verletzungen oder Beschädigung führen.

- * Den Projektor nicht während des Betriebs bewegen. Ziehen Sie das Netzkabel und alle Anschlusskabel ab, und schließen Sie den Objektivschieber, bevor Sie den Projektor bewegen.
- * Den Projektor vor Stößen oder Erschütterungen schützen.
- * Benutzen Sie zum Transportieren die mitgelieferte Tragetasche, falls vorhanden, gemäß der Gebrauchsanweisung der Tragetasche.



Keine Gegenstände auf den Projektor stellen.

Das Ablegen von Gegenständen auf dem Projektor kann zu Gleichgewichtsverlust oder Umkippen führen und Verletzungen oder Beschädigung zur Folge haben. Lassen Sie in Haushalten mit Kindern besondere Vorsicht walten.



Feuchte oder staubige Orte vermeiden.

Wird der Projektor einer sehr feuchten oder staubigen Umgebung mit öligem Ruß oder korrosiven Gasen ausgesetzt, kann es zu einem Brand oder elektrischen Schlag kommen.

- * Den Projektor nicht in der Nähe einer Küche, eines Luftbefeuchters oder an einem anderen Ort mit ölhaltigem Rauch oder hoher Luftfeuchtigkeit abstellen.



Heiße Umgebungen vermeiden.

Die Hitze könnte sich schädlich auf das Gehäuse und andere Teile des Projektors auswirken. Setzen Sie den Projektor, die Fernbedienung und andere Teile nicht direktem Sonnenlicht oder der Hitze eines Heizkörpers usw. aus.



Das Netzkabel zur Aufbewahrung abziehen.

- * Aus Sicherheitsgründen ist das Netzkabel abzuziehen, wenn der Projektor längere Zeit nicht benutzt wird.
- * Vor der Reinigung den Projektor ausschalten und vom Stromnetz trennen. Eine Missachtung kann zu einem Brand oder elektrischen Schlag führen.



Den Netzstecker aus der Steckdose ziehen.

Lassen Sie die Innenteile des Projektors etwa alle zwei Jahre von Ihrem Händler reinigen.

Staubansammlung im Inneren des Projektors kann zu einem Brand oder Funktionsstörungen führen.

Die Reinigung der Innenteile ist wirksamer, wenn sie vor Beginn von feuchten Jahreszeiten, z.B. vor der Regenzeit, durchgeführt wird.

- * Versuchen Sie nicht, die Innenteile selbst zu reinigen, weil dies gefährlich ist.



THE TRUSTED SOURCE FOR PROJECTOR LAMPS AND ACCESSORIES

HINWEIS

Setzen Sie die Fernbedienung keinen Erschütterungen aus.

Erschütterungen können eine Beschädigung oder Funktionsstörung der Fernbedienung verursachen.

- * Lassen Sie die Fernbedienung nicht fallen.
- * Stellen Sie nicht den Projektor oder andere schwere Gegenstände auf die Fernbedienung.

Behandeln Sie das Objektiv mit Sorgfalt.

- * Wenn der Projektor nicht benutzt wird, schließen Sie den Objektivschieber, um die Linsenoberfläche vor Kratzern zu schützen.
- * Unterlassen Sie das Berühren des Objektivs, um Verschlechterung der Bildqualität durch Beschlagen oder Verschmutzen des Objektivs zu vermeiden.
- * Verwenden Sie zum Reinigen des Objektivs im Fachhandel erhältliches Objektivpapier (zur Reinigung von Kameras, Brillen usw.). Achten Sie darauf, dass Sie das Objektiv nicht mit harten Gegenständen verkratzen.

Reinigen Sie den Luftfilter etwa alle 100 Betriebsstunden.

Wenn der Luftfilter mit Staub usw. zugesetzt wird, zeigt der Projektor eine Meldung wie "ANS. LUFTSTROM UBERPR." an. Schalten Sie in diesem Fall den Projektor aus, um einen Anstieg des internen Wärmepegels zu verhüten. Reinigen Sie den Luftfilter, um den Kühlluftstrom wieder zu normalisieren.

- * Schalten Sie den Projektor nicht ohne Luftfilter ein.
- * Falls der Luftfilter beschädigt wird oder verloren geht, bestellen Sie den im Bedienungsanleitung angegebenen Luftfilter bei Ihrem Händler.

Pflege des Gehäuses und der Fernbedienung.

Unsachgemäße Pflege kann negative Auswirkungen wie Verfärbung, Lackablösung usw. zur Folge haben.

- * Verwenden Sie ein weiches Tuch zur Reinigung des Gehäuses und der Bedienungstafel des Projektors sowie der Fernbedienung. Bei starker Verschmutzung ein neutrales Reinigungsmittel mit Wasser verdünnen, ein weiches Tuch durchtränken und auswringen, und anschließend mit einem trockenen, weichen Tuch nachwischen. Kein unverdünntes Reinigungsmittel direkt auftragen.
- * Keine Aerosol-Sprays, Lösungsmittel, leichtflüchtige Substanzen oder Scheuermittel verwenden.

Wenn Sie chemisch behandelte Tücher verwenden, sollten Sie die Gebrauchsanweisung lesen und befolgen.

- * Vermeiden Sie engen Kontakt mit Gummi oder Vinyl über längere Zeit.

HINWEIS

Starke Lichtstrahlen vermeiden.

Starker Lichteinfall (wie direktes Sonnenlicht oder Zimmerbeleuchtung) auf den Fernbedienungssensor kann die Fernbedienung funktionsunfähig machen.

Funkfeldeinfluss vermeiden.

Jeder Funkfeldeinfluss kann Bildstörungen oder Rauschen verursachen.

- * Vermeiden Sie den Einsatz von Hochfrequenz erzeugenden Geräten (z.B. Mobiltelefone, Funkgeräte usw.) in der Nähe des Projektors.

Hinweise zur Projektionsqualität.

Die Projektionsqualität des Projektors (z.B. Farbe, Kontrast usw.) hängt von der Beschaffenheit der Leinwand ab, weil der Projektor ein Flüssigkristallfeld verwendet. Die Projektionsqualität kann von der Anzeige einer Kathodenstrahlröhre abweichen.

- * Verwenden Sie keine polarisierte Leinwand. Diese kann ein rotes Bild verursachen.

Die Stromversorgung in der richtigen Reihenfolge ein- und ausschalten.

Um Störungen zu vermeiden, sollte der Projektor in der unten angegebenen Reihenfolge ein- und ausgeschaltet werden, wenn nicht anders angegeben.

- * Den Projektor vor dem Computer oder Videorecorder einschalten.
- * Den Projektor nach dem Computer oder Videorecorder ausschalten.

Die Augen vor Ermüdung schützen.

Geben Sie Ihren Augen regelmäßige Erholungspausen.

Die Lautstärke nicht zu hoch einstellen, um Nachbarn nicht zu stören.

- * Wenn Sie den Projektor zu später Stunde benutzen, sollten Sie die Lautstärke verringern und die Fenster schließen, um die Nachbarn nicht zu stören.

Anschluß an einen Notebook-Computer

Sorgen Sie beim Anschluß an einen Notebook-Computer dafür, daß der externe RGB-Bildausgang wirksam ist (stellen Sie auf CRT-Anzeige oder auf gleichzeitige LCD- und CRT-Anzeige). Bitte beziehen Sie sich für weitere Informationen auf die Bedienungsanleitung für das Notebook.



Discount-Merchant.com (800) 281-8860
THE TRUSTED SOURCE FOR PROJECTOR LAMPS AND ACCESSORIES

AVANT L'UTILISATION

Explication des symboles

Différents symboles sont utilisés dans le manuel de fonctionnement et sur le produit lui-même pour garantir une utilisation correcte de l'appareil, protéger l'utilisateur et le public contre les dangers éventuels ou contre les dommages matériels. Lisez attentivement la description qui en est donnée ci-après afin d'en assimiler la signification et le contenu.



AVERTISSEMENT

Risques de blessure corporelle grave ou mortelle en cas de mauvaise manipulation consécutive à un manquement aux recommandations indiqués sous ce symbole.



ATTENTION

Risques de blessure corporelle ou de dommage matériel en cas de mauvaise manipulation consécutive à un manquement aux recommandations indiquées sous ce symbole.

FRANÇAIS

Symboles types



Ce symbole indique un avertissement supplémentaire (y compris des précautions). Il est accompagné d'une illustration qui précise la nature du danger.



Ce symbole indique une opération interdite. Les détails sont précisés à l'intérieur de l'illustration ou à côté (celui de gauche indique qu'il est interdit de démonter l'appareil).



Ce symbole indique une opération obligatoire. Les détails sont précisés à l'intérieur de l'illustration ou à côté (celui de gauche indique qu'il faut débrancher le fil électrique de la prise de courant murale).



Discount-Merchant.com (800) 281-8860
THE TRUSTED SOURCE FOR PROJECTOR LAMPS AND ACCESSORIES

CONSIGNES DE SÉCURITÉ

AVERTISSEMENT

Ne jamais utiliser le projecteur si vous détectez un problème quelconque.

Tout fonctionnement anormal, se manifestant par de la fumée, une odeur suspecte, pas d'image, pas de son, trop de son, un boîtier, des éléments ou des câbles défectueux, la pénétration de liquides ou de corps étrangers etc., peut provoquer un incendie ou un choc électrique.

Dans ce cas, mettez immédiatement l'appareil hors tension, puis débranchez la fiche de la prise électrique. Une fois que vous êtes sûr que la fumée ou l'odeur a disparu, contactez votre revendeur. N'essayez jamais d'effectuer les réparations vous-même car cela peut être dangereux.

* La prise électrique doit se trouver à proximité du projecteur et être facilement accessible.



Débranchez
la prise
murale

Ne jamais introduire de liquides ou de corps étrangers.

L'introduction de liquides ou de corps étrangers peut occasionner un incendie ou un choc électrique. Soyez particulièrement vigilant si vous avez des enfants à la maison.

En cas de pénétration de liquides ou de corps étrangers dans le projecteur, mettez immédiatement l'appareil hors tension, débranchez la fiche de la prise électrique et contactez votre revendeur.

* Ne placez pas le projecteur dans la salle de bains

* N'exposez pas le projecteur à la pluie ou à l'humidité.

* Ne placez pas de fleurs, de vases, de pots, de tasses, de produits de beauté, ni de liquides tels que de l'eau, etc. sur ou à proximité du projecteur.

* Ne placez pas de métaux, de combustibles, etc. sur ou à proximité du projecteur.



N'effectuez jamais de modifications vous-même.

Le projecteur contient des composants haute tension. Toute modification risque de provoquer un incendie ou un choc électrique.

* N'ouvrez jamais le boîtier.

* Pour toute réparation ou nettoyage de l'intérieur de l'appareil, contactez votre revendeur.



Ne pas
démonter

Le projecteur ne doit subir aucun choc ou impact.

Si le projecteur subit un choc et/ou qu'il se casse, vous risquez de vous blesser.

Par ailleurs, si vous continuez à l'utiliser, vous risquez de provoquer un incendie ou un choc électrique.

Si le projecteur subit un choc, mettez immédiatement l'appareil hors tension, débranchez la fiche de la prise électrique et contactez votre revendeur.



CONSIGNES DE SÉCURITÉ (Suite)

AVERTISSEMENT

Ne placez pas le projecteur sur une surface instable.

Si le projecteur tombe ou se casse, vous risquez de vous blesser et de recevoir un choc électrique ou de provoquer un incendie si vous continuez à l'utiliser.

- * Ne placez pas le projecteur sur une surface instable, inclinée ou vibrante telle qu'un support branlant ou incliné.
- * Utilisez les freins pour roulettes en plaçant le projecteur sur un support à roulettes.
- * Ne placez pas le projecteur sur le côté, avec l'objectif dirigé vers le haut ou vers le bas.



Faites attention, le projecteur peut atteindre des températures élevées.

Lorsque la lampe est allumée, elle génère des températures élevées. Celles-ci peuvent provoquer un incendie ou des brûlures. Soyez particulièrement vigilant si vous avez des enfants à la maison.

Ne touchez pas l'objectif, les ventilateurs ni les fentes de ventilation pendant que vous utilisez l'appareil ou juste après son utilisation, afin d'éviter de vous brûler. Contrôlez la ventilation.

- * Laissez un espace de 30 cm ou plus entre les côtés du projecteur et d'autres objets, comme par exemple des murs.
- * Ne placez pas le projecteur sur une table en métal.
- * Ne placez aucun objet à proximité de l'objectif, des ventilateurs et des fentes de ventilation du projecteur.
- * Ne bloquez jamais le ventilateur ni les fentes de ventilation.
- * N'utilisez pas l'appareil avec les trous de ventilation dirigés vers le bas.
- * Ne couvrez pas le projecteur avec une nappe, etc.
- * Ne placez pas le projecteur sur un tapis ou sur un dessus-de-lit.



Ne regardez jamais au travers de l'objectif ou des fentes lorsque la lampe est allumée.

Le puissant faisceau lumineux risque de gravement affecter votre vue. Soyez particulièrement prudent si vous avez des enfants à la maison.



Utilisez uniquement la prise électrique appropriée.

Un courant électrique incorrect risque de provoquer un incendie ou un choc électrique. Utilisez seulement la prise électrique appropriée en fonction des indications précisées sur le projecteur et des normes de sécurité.

Le cordon électrique fourni avec le projecteur ne doit être utilisé qu'en fonction de la prise électrique que vous allez utiliser.



Faites attention au branchement du cordon électrique.

Tout branchement incorrect du cordon électrique risque de provoquer un incendie ou un choc électrique.

Ne touchez pas au cordon électrique lorsque vous avez les mains mouillées.

- * Veillez à ce que la partie du cordon électrique qui se branche dans la prise soit propre (sans poussière) avant de l'utiliser. Utilisez un chiffon sec et doux pour nettoyer la fiche d'alimentation.
- * Insérez à fond la fiche d'alimentation dans la prise électrique. Évitez d'utiliser une prise électrique mal fixée, non reliée à la terre ou avec un faux contact.



CONSIGNES DE SÉCURITÉ (Suite)

AVERTISSEMENT

Faites attention lors de la manipulation de la lampe source de lumière.

Une manipulation incorrecte de la lampe peut entraîner son explosion.

- * La lampe est faite de verre. Ne la soumettez pas à des chocs ni ne la rayez.
- * Lors du remplacement de la lampe, mettez l'appareil hors tension, retirez le cordon d'alimentation et attendez 45 minutes pour que la lampe refroidisse. À haute pression, quand la lampe n'a pas encore refroidi, une mauvaise manipulation peut la faire exploser.
- * La lampe a une durée de vie déterminée. Pour plus de détails, lisez le mode d'emploi. Veuillez contacter votre revendeur ou un service d'assistance pour son remplacement. N'utilisez pas une vieille lampe. Cela pourrait aussi causer son explosion.



Soyez prudent lorsque vous manipulez le cordon électrique et les câbles de connexion externes.

Si vous continuez à utiliser un cordon électrique ou des câbles endommagés, vous risquez de provoquer un incendie ou un choc électrique. Évitez d'exposer le cordon électrique et les câbles à une chaleur, une pression ou une tension trop élevée.

Si le cordon électrique ou les câbles sont endommagés (si les fils sont dénudés ou cassés), contactez votre revendeur.

- * Ne placez pas le projecteur ou des objets lourds sur le cordon électrique ou sur les câbles. Évitez aussi de les recouvrir de quoi que ce soit qui pourrait les dissimuler et risquer que des objets lourds soient placés dessus par inadvertance.
- * Ne tirez pas sur le cordon électrique ou sur les câbles. Pour brancher ou débrancher le cordon électrique ou sur les câbles, faites-le en tenant la prise ou le connecteur d'une main, pendant que vous branchez ou débranchez le cordon électrique ou les câbles de l'autre.
- * Ne placez pas le cordon près du chauffage.
- * Évitez de trop courber le cordon électrique.
- * N'essayez pas de réparer le cordon électrique.



Manipulez la pile de la télécommande avec précaution.

Toute manipulation incorrecte de la télécommande risque de provoquer un incendie ou d'entraîner des dommages corporels. La pile peut exploser si elle n'est pas manipulée de façon appropriée.

- * Conservez la pile hors de la portée des enfants et des animaux domestiques. En cas d'ingestion, consultez immédiatement un médecin afin qu'il prescrive un traitement d'urgence.
- * Ne laissez pas la pile au contact du feu ou de l'eau.
- * Évitez tout environnement avec présence de flammes ou de températures élevées.
- * Ne tenez pas la pile par les bornes métalliques.
- * Conservez la pile dans un endroit frais et sec, à l'abri de la lumière.
- * Évitez de court-circuiter la pile.
- * Évitez de recharger, de démonter ou de souder la pile.
- * Évitez que la pile subisse un choc physique.
- * Utilisez uniquement la pile spécifiée dans le manuel de l'utilisateur.
- * Veillez à ce que les bornes plus et moins soient correctement alignées lors du chargement de la pile.
- * Si la pile fuit, essuyez le liquide et remplacez la pile. Si vous avez du liquide sur le corps ou sur vos vêtements, rincez le tout abondamment à l'eau.
- * Respectez la législation locale en matière d'élimination des piles de batterie.



CONSIGNES DE SÉCURITÉ (Suite)

ATTENTION

Soyez prudent lorsque vous déplacez le projecteur.

Toute négligence de votre part risque de provoquer des dommages corporels ou matériels.

- * Ne déplacez pas le projecteur pendant que vous l'utilisez. Avant de le déplacer, débranchez le cordon électrique et toutes les connexions externes, et fermez la porte coulissante de l'objectif. 
- * Évitez tout impact ou choc sur le projecteur.
- * Pour le transporter, utilisez le sac de transport joint si nécessaire, en suivant les instructions du manuel du sac de transport.

Ne placez aucun objet sur le projecteur.

Tout objet placé sur le projecteur risque de perdre l'équilibre ou de tomber et de provoquer des dommages corporels ou matériels. Soyez particulièrement prudent si vous avez des enfants à la maison. 

Évitez d'exposer le projecteur à l'humidité ou à la poussière.

Toute exposition du projecteur à une forte humidité, à la poussière, à de la suie ou à un gaz corrosif risque de provoquer un incendie ou un choc électrique. 

- * Ne placez pas le projecteur à proximité de la cuisine, d'un humidificateur ou d'autres endroits humides ou chargés de fumées grasses.

Évitez d'exposer le projecteur à des températures élevées.

La chaleur peut avoir des effets nocifs sur le boîtier du projecteur ainsi que sur d'autres composants. Évitez d'exposer le projecteur, la télécommande et d'autres composants à la lumière directe du soleil ou à proximité d'objets chauds tels que le chauffage, etc. 

Pour une déconnexion totale, retirez le cordon électrique.

- * Pour des raisons de sécurité, débranchez le cordon électrique si vous ne comptez pas utiliser le projecteur pendant de longues périodes. 
- * Avant de nettoyer l'appareil, mettez-le hors tension et débranchez-le de l'alimentation électrique. Toute négligence de votre part, risque de provoquer un incendie ou un choc électrique.

Débranchez la prise murale

Demandez à votre revendeur de nettoyer l'intérieur du projecteur environ tous les deux ans.

Une poussière accumulée à l'intérieur du projecteur risque de provoquer un incendie ou un mauvais fonctionnement de l'appareil. 

Le nettoyage interne sera plus efficace s'il est effectué par temps sec.

- * Évitez de nettoyer l'intérieur de l'appareil vous-même, afin d'éviter tout danger.

REMARQUE

Évitez tout impact physique sur la télécommande.

Tout impact physique risque d'endommager ou d'entraîner un mauvais fonctionnement de la télécommande.

- * Veillez à ne pas laisser tomber la télécommande par terre.
- * Ne placez pas le projecteur ou des objets lourds sur la télécommande.

Prenez soin de l'objectif.

- * Fermez la porte coulissante de l'objectif afin d'éviter de rayer la surface de l'objectif lorsque vous n'utilisez pas le projecteur.
- * Ne touchez pas l'objectif afin d'éviter que de la buée ou de la poussière ne détériore la qualité de l'affichage.
- * Pour nettoyer l'objectif, utilisez les chiffons spéciaux vendus dans le commerce (ceux qui sont utilisés pour nettoyer les appareils photos, les lunettes de vue, etc.). Veillez à ne pas rayer l'objectif avec des objets durs.

Nettoyez le filtre à air environ toutes les 100 heures.

Lorsque le filtre à air est plein de poussière, etc. il se peut que le projecteur affiche un message du type "VÉR. DÉBIT AIR". Vous pouvez aussi mettre le projecteur hors tension afin d'éviter toute hausse de la température interne. Rétablissez la ventilation normale par le filtre à air.

- * Évitez de mettre le projecteur sous tension sans le filtre à air.
- * Si le filtre à air est endommagé ou perdu, commandez à votre revendeur le filtre à air indiqué dans la manuel de l'utilisateur.

Prenez soin du boîtier et de la télécommande.

Toute négligence de votre part dans l'entretien de ces éléments peut entraîner la décoloration ou l'écaillage de la peinture, etc.

- * Utilisez un chiffon doux pour nettoyer le boîtier et le panneau de configuration du projecteur et de la télécommande. Si ces pièces sont très sales, diluez un produit détergent neutre dans un peu d'eau, trempez un chiffon doux dans cette solution et essorez-le, puis essuyez les parties sales avant de passer un chiffon doux et sec dessus. Évitez d'utiliser un produit détergent non dilué directement sur les parties à nettoyer.
- * Évitez d'utiliser des aérosols, des solvants, des matières volatiles ou des produits de nettoyage abrasifs.
- * Avant d'utiliser des nettoyants chimiques, lisez toujours attentivement la notice et respectez les instructions du mode d'emploi.
- * Évitez tout contact prolongé et permanent avec du caoutchouc ou du vinyle.

REMARQUE

Évitez toute exposition à de forts rayonnements.

Tout fort rayonnement (tels que les rayonnements directs du soleil ou la lumière artificielle) vers les capteurs de la télécommande peut rendre la télécommande inutilisable.

Éviter les interférences radio.

Toute interférence par radiation risque de déformer les images ou les bruits.

* Évitez l'utilisation de tout générateur radio tel qu'un téléphone mobile, un émetteur-récepteur etc. à proximité du projecteur.

À propos des caractéristiques d'affichage.

Le mode d'affichage du projecteur (tel que la couleur, le contraste, etc.) dépend des caractéristiques de l'écran, car le projecteur utilise un panneau avec affichage à cristaux liquides. Le mode d'affichage peut varier par rapport à celui d'un écran cathodique.

* Évitez l'utilisation d'un écran polarisant. Il risque d'engendrer des images rouges.

Protocole de mise sous/hors tension.

Afin d'éviter tout problème et sauf indication contraire, effectuez la mise sous/hors tension dans l'ordre mentionné ci-dessous :

* Mettez le projecteur sous tension avant de mettre l'ordinateur ou le magnétoscope sous tension.

* Mettez le projecteur hors tension avant de mettre l'ordinateur ou le magnétoscope hors tension.

Faites attention de ne pas vous fatiguer les yeux.

Reposez-vous les yeux régulièrement.

Réglez le volume sonore à un niveau correct, afin de ne pas déranger les autres.

* Il est préférable de baisser le volume et de fermer les fenêtres la nuit, afin de ne pas déranger le voisinage.

Connexion avec un ordinateur portable

Lors de la connexion avec un ordinateur portable, réglez pour valider la sortie vidéo RVB extérieure (réglage sur l'écran à tube cathodique ou simultanément sur l'écran LCD et à tube cathodique).

Consultez le manuel de l'utilisateur ou le mode d'emploi de l'ordinateur portable pour plus d'informations.

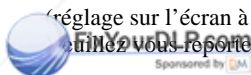

Discount-Merchant.com (800) 281-8860
THE TRUSTED SOURCE FOR PROJECTOR LAMPS AND ACCESSORIES

PRIMA DELL'USO

Simboli

Nel presente manuale di istruzioni e sui prodotti stessi sono utilizzati diversi simboli atti a garantire un corretto utilizzo, evitare rischi per l'utente e per le altre persone, nonché evitare danni alla proprietà. I significati di questi simboli sono qui di seguito riportati. E' importante che legiate attentamente le descrizioni e ne comprendiate totalmente il significato.



AVVERTENZA

Questo simbolo riporta un tipo di informazione da non ignorare per evitare rischi di lesioni personali o anche morte, per maneggiamento errato dell'apparecchio.



ATTENZIONE

Questo simbolo riporta un tipo di informazione da non ignorare per evitare eventuali rischi di lesioni personali o danni fisici per maneggiamento errato dell'apparecchio.

Simboli tipici



Questo simbolo indica un'avvertenza aggiuntiva (note di attenzione incluse). Viene riportata un'illustrazione atta a chiarirne il contenuto.



Questo simbolo indica un divieto. Il contenuto sarà chiaramente indicato nell'ambito di un'illustrazione o nelle sue vicinanze (il simbolo riportato sulla sinistra indica divieto di smontaggio).



Questo simbolo indica un obbligo. Il contenuto sarà chiaramente indicato nell'ambito di un'illustrazione o nelle sue vicinanze (il simbolo riportato sulla sinistra indica che la spina deve essere scollegata dalla presa di corrente).



Discount-Merchant.com (800) 281-8860
THE TRUSTED SOURCE FOR PROJECTOR LAMPS AND ACCESSORIES

PRECAUZIONI DI SICUREZZA

AVVERTENZA

Non usare mai il proiettore in caso di problemi.

Un funzionamento anormale quale emissione di fumo, odori strani, nessuna visualizzazione d'immagine, nessuna emissione di suono o suono troppo alto, parte esterna del proiettore o elementi o cavi danneggiati, penetrazione di liquidi o di corpi estranei, etc. può provocare incendi o scosse elettriche. In questo caso, disattivare immediatamente l'interruttore d'alimentazione e staccare la spina dalla presa. Controllare che non vi sia più emissione di fumo o d'odore, quindi rivolgersi al rivenditore. Non tentare mai di ripararlo personalmente perché potrebbe essere pericoloso.

* La presa deve essere vicina al proiettore e facilmente accessibile.



Scollegare la spina dalla presa di corrente

Non introdurre liquidi o corpi estranei.

La penetrazione di liquidi o di corpi estranei potrebbe provocare incendi o scosse elettriche.

Adottare le precauzioni necessarie nelle case dove vi sono bambini.

In caso di penetrazione di liquidi o di corpi estranei all'interno del proiettore, disattivare immediatamente l'interruttore d'alimentazione e staccare la spina dalla presa e rivolgersi al rivenditore.

* Non collocare il proiettore nel bagno.

* Non esporre il proiettore alla pioggia o all'umidità.

* Non collocare vasi di fiori, vasi, tazze, cosmetici, liquidi, quali acqua, etc. sopra o attorno al proiettore.

* Non collocare oggetti di metallo, combustibili, etc. sopra o attorno al proiettore.



ITALIANO

Non eseguire modifiche.

Il proiettore contiene componenti ad alta tensione. Eventuali modifiche potrebbero provocare incendi o scosse elettriche.

* Non aprire mai la parte esterna del proiettore.

* Chiedere al rivenditore di eseguire le riparazioni e la pulizia interna.



Non smontare.

Non urtare o far cadere il proiettore.

L'urto e/o la rottura del proiettore potrebbe provocare delle lesioni, mentre l'uso continuo in queste condizioni potrebbe provocare incendi o scosse elettriche.

In caso d'urto, disattivare immediatamente l'interruttore d'alimentazione, staccare la spina dalla presa e rivolgersi al rivenditore.



 Discount-Merchant.com (800) 281-8860
THE TRUSTED SOURCE FOR PROJECTOR LAMPS AND ACCESSORIES

AVVERTENZA

Non collocare il proiettore su una superficie instabile.

La caduta e/o la rottura del proiettore potrebbe provocare delle lesioni, mentre l'uso continuo in queste condizioni potrebbe provocare incendi o scosse elettriche.

- * Non collocare il proiettore su superfici instabili, inclinate o vibranti quali sostegni oscillanti o inclinati.
- * Bloccare le ruote con i relativi fermi se il proiettore è posato su un sostegno dotato di ruote.
- * Non collocare il proiettore in posizione capovolta o con l'obiettivo rivolto verso l'alto o verso il basso.



Controllare le temperature elevate del proiettore.

L'accensione della lampada genera alte temperature. Potrebbe essere fonte d'incendio o di bruciature. Adottare particolari precauzioni nelle case dove vi sono dei bambini.

Non toccare le lenti, i ventilatori e le aperture di ventilazione durante l'uso o subito dopo, per evitare bruciature. Controllare la ventilazione.

- * Mantenere uno spazio pari o uguale a 30 cm tra i lati ed altri oggetti, per esempio muri.
- * Non collocare il proiettore su un tavolo metallico.
- * Non collocare nulla sulle lenti, sui ventilatori e sulle aperture di ventilazione del proiettore.
- * Non bloccare mai i ventilatori né le aperture di ventilazione.
- * Non utilizzare con i fori di ventilazione rivolti verso il basso.
- * Non coprire il proiettore con tovaglie, etc.
- * Non collocare il proiettore su un tappeto o su un letto.



Non guardare mai attraverso le lenti o le aperture quando la lampada è accesa.

La luce potente può danneggiare la vista. Adottare particolari precauzioni nelle case dove vi sono dei bambini.



Usare solo la presa d'alimentazione corretta.

Un'alimentazione errata potrebbe provocare incendi o scosse elettriche. Usare solo la presa d'alimentazione corretta secondo le indicazioni che figurano sul proiettore e le norme di sicurezza.

- * Il cordone d'alimentazione incluso deve essere usato in base al tipo di presa usato.



Controllare il collegamento del cordone d'alimentazione.

Il collegamento errato del cordone d'alimentazione potrebbe provocare incendi o scosse elettriche.

- * Non toccare il cordone d'alimentazione con le mani bagnate.
- * Controllare che la parte di collegamento del cordone d'alimentazione sia pulita (priva di polvere), prima di usarlo. Usare un panno morbido e asciutto per pulire la spina del cordone.
- * Inserire la spina nella presa in modo fermo. Evitare di usare una presa allentata, insicura o un contatto difettoso.



AVVERTENZA

Fare attenzione nel maneggiare la lampada sorgente di luce.

Maneggiare la lampada in modo errato può essere causa di esplosione.

- * La lampada è di vetro e pertanto bisogna evitare di esporla a rischi d'urto o di graffiatura.
- * Prima di sostituire la lampada, spegnere e rimuovere il cavo di alimentazione in c.a., e attendere 45 minuti perché la lampada si raffreddi. La lampada calda può raggiungere una pressione molto alta e, se maneggiata impropriamente, può esplodere.
- * La lampada ha una durata di vita di servizio utile. Per i dettagli, leggere il manuale di istruzioni. Per la sostituzione, rivolgersi al rivenditore di fiducia o il centro di assistenza tecnica. Non sostituire con una lampada vecchia. Anche questo potrebbe essere causa di esplosione della lampada.



Usare cautela nel maneggiare il cordone d'alimentazione ed i cavi di collegamento esterni.

L'uso continuato di un cordone d'alimentazione o di cavi danneggiati può provocare incendi o scosse elettriche. Non riscaldare, premere o tendere in modo eccessivo il cordone d'alimentazione ed i cavi.

Se il cordone d'alimentazione o i cavi sono danneggiati (conduttori interni esposti o rotti, etc.) rivolgersi al rivenditore.

- * Non collocare il proiettore o oggetti pesanti sul cordone d'alimentazione e sui cavi. Non collocare inoltre coperture, etc. sugli stessi perché ciò potrebbe favorire l'appoggio accidentale di oggetti pesanti sul cordone d'alimentazione o sui cavi nascosti.
- * Non tirare il cordone d'alimentazione ed i cavi. Per collegare e scollegare il cordone d'alimentazione ed i cavi, tenere con la mano la spina o il connettore.
- * Non collocare il cordone vicino ad un riscaldatore.
- * Evitare di piegare il cordone d'alimentazione ad angolo retto.
- * Non tentare di eseguire interventi sul cordone d'alimentazione.



ITALIANO

Usare cautela nel maneggiare le pile del telecomando.

La manipolazione errata delle pile potrebbe provocare incendi o lesioni personali. Le pile possono esplodere se non sono maneggiate correttamente.

- * Tenere le pile lontane dalla portata di bambini e animali domestici. In caso d'ingestione rivolgersi immediatamente ad un medico per un soccorso tempestivo.
- * Non lasciare cadere le pile nel fuoco o nell'acqua.
- * Evitare ambienti a rischio d'incendio o di alte temperature.
- * Non prendere le pile con pinzette metalliche.
- * Conservare le pile in luogo scuro, fresco e asciutto.
- * Evitare di cortocircuitare le pile.
- * Non ricaricare, smontare, né saldare le pile.
- * Non far cadere le pile.
- * Usare solo le pile indicate nel manuale dell'utilizzatore.
- * Controllare che i morsetti positivo e negativo siano correttamente allineati quando si caricano le pile.
- * In caso di perdite dalle pile, pulire accuratamente il liquido fuoriuscito e sostituire le pile. Se il liquido fuoriuscito entra in contatto con la pelle o con i vestiti, sciacquare abbondantemente con acqua.
- * Rispettare le norme locali per lo smaltimento delle pile usate.



PRECAUZIONI DI SICUREZZA (continua)

ATTENZIONE

Usare cautela nello spostare il proiettore.

La negligenza può provocare lesioni o danni.

- * Non spostare il proiettore durante l'uso. Prima di spostarlo, scollegare il cordone d'alimentazione e tutti i collegamenti esterni e chiudere lo sportellino scorrevole delle lenti.
- * Evitate urti o colpi al proiettore.
- * Per trasportarlo, usare la borsa acclusa, se fornita, seguendo le istruzioni del manuale della borsa.



Non collocare nulla sulla parte superiore del proiettore.

Il deposito di oggetti sul proiettore può provocare squilibrio o cadute con conseguenti lesioni personali o danni. Adottare le precauzioni necessarie nelle case dove vi sono bambini.



Evitare luoghi polverosi e umidi.

Collocare il proiettore in un luogo umido, polveroso, dove siano presenti fuliggine o gas corrosivi potrebbe provocare incendi o scosse elettriche.

- * Non collocare vicino a cucine, umidificatori o altri luoghi dove siano presenti fumi oleosi o umidità.



Evitare ambienti con temperature elevate.

Il calore può influenzare in modo negativo la parte esterna del proiettore ed altre parti. Non esporre il proiettore, il telecomando ed altre parti alla luce diretta del sole o vicino ad un oggetto caldo, quale un riscaldatore, etc.



Togliere il cordone d'alimentazione per la disconnessione totale.

- * per motivi di sicurezza, scollegare il cordone d'alimentazione se il proiettore non sarà usato per periodi prolungati.
- * Prima di pulirlo disattivare e scollegare dalla presa il proiettore. Il non rispetto di quest'istruzione potrebbe provocare incendi o scosse elettriche.



Scollegare la spina dalla presa di corrente

Richiedere al rivenditore di pulire l'interno del proiettore ogni due anni circa.

L'accumulo di polvere all'interno del proiettore può provocare incendi o errato funzionamento.

La pulizia dell'interno del proiettore è più efficace se è eseguita prima dei periodi umidi, quali la stagione delle piogge.

- * Non pulire l'interno personalmente perché è pericoloso.



NOTA

Evitare ogni urto al telecomando.

Un urto può danneggiare o provocare un errato funzionamento del telecomando.

- * Prestare attenzione a non far cadere il telecomando.
- * Non appoggiare il proiettore o oggetti pesanti sul telecomando.

Avere cura delle lenti.

- * Chiudere lo sportellino scorrevole delle lenti per evitare graffi alla superficie delle lenti quando il proiettore non è in uso.
- * Non toccare le lenti per evitare di appannare o sporcare le lenti con conseguente deterioramento della qualità dell'immagine.
- * Usare tessuti specifici per lenti, disponibili in commercio, per pulire le lenti (per la pulizia delle macchine fotografiche, occhiali, etc.). Prestare attenzione a non graffiare le lenti con oggetti duri.

Pulire il filtro dell'aria ogni 100 ore circa.

Quando il filtro è intasato di polvere, etc. il proiettore può visualizzare un messaggio del tipo "CONTROLLO FLUSSO ARIA" o spegnere il proiettore per evitare che aumenti la temperatura all'interno dello stesso. Controllare il filtro dell'aria per garantire la ventilazione normale.

- * Non accendere il proiettore senza il filtro dell'aria.
- * Se il filtro dell'aria è danneggiato o manca, richiedere al rivenditore il filtro dell'aria specificato nel manuale dell'utilizzatore.

Avere cura della parte esterna del proiettore e del telecomando.

Un'errata cura può provocare danni quali scolorimento, distacco della vernice, etc.

- * Usare un panno morbido per pulire la parte esterna del proiettore, il quadro di comando ed il telecomando. Se molto sporchi, diluire un detergente neutro in acqua, bagnare e strizzare bene il panno morbido, pulire, quindi asciugare con un panno asciutto. Non usare nessun detergente senza diluirlo.
- * Non usare prodotti in spray, solventi, sostanze volatili o detersivi abrasivi.
- * Prima di usare sostanze chimiche, leggere e seguire scrupolosamente le istruzioni fornite.
- * Non lasciare per lungo tempo a contatto con gomma o vinile.



Discount-Merchant.com (800) 281-8860
THE TRUSTED SOURCE FOR PROJECTOR LAMPS AND ACCESSORIES

NOTA

Evitare raggi di luce molto forti.

Qualsiasi raggio di luce (quali raggi solari diretti o illuminazione di una stanza) diretto sul sensore del telecomando può danneggiarlo.

Evitare le interferenze radio.

Qualsiasi interferenza radio può dare origine ad immagini confuse o a rumore.

* Evitare di collocare generatori di onde radio, quali telefoni portatili, ricetrasmittitori, etc. vicino al proiettore.

Caratteristiche di visualizzazione.

Le condizioni di visualizzazione del proiettore (quali colori, contrasto, etc.) dipendono dalle caratteristiche dello schermo, perché il proiettore usa un display a cristalli liquidi. Le condizioni di visualizzazione possono essere diverse da quelle del CRT.

* Non usare schermi polarizzati. Possono dare origine a immagini rosse.

Accendere/Spegnere il proiettore nel modo corretto.

Per evitare problemi, accendere/spegnere il proiettore nel modo corretto secondo quando indicato nel seguito se non diversamente specificato.

* Accendere il proiettore prima del computer o del videoregistratore.

* Spegnere il proiettore dopo il computer o il videoregistratore.

Aver cura di non affaticare la vista.

Far riposare periodicamente gli occhi.

Impostare il volume su un livello adeguato onde evitare di disturbare altre persone.

* E' consigliabile mantenere il volume basso e chiudere le finestre di notte per non disturbare i vicini.

Collegamento con un computer di tipo notebook

Per collegare un computer di tipo notebook, abilitare l'uscita immagine esterna RGB (predisporre la visualizzazione CRT o la visualizzazione simultanea LCD e CRT).

Leggere il manuale d'istruzioni del computer notebook per maggiori informazioni.



Discount-Merchant.com (800) 281-8860
THE TRUSTED SOURCE FOR PROJECTOR LAMPS AND ACCESSORIES

ANTES DEL USO

Acerca de los símbolos

En este manual de instrucciones y en el producto propiamente dicho, se utilizan varios símbolos para asegurar un uso correcto y prevenir riesgos de lesiones personales o de daños materiales. Los significados de estos símbolos se explican a continuación. Es importante que usted lea y comprenda cabalmente todas estas medidas de seguridad.



ADVERTENCIA

Este símbolo estipula la existencia de riesgos de muerte o lesiones de gravedad, si el producto llega a operarse



PRECAUCIÓN

Este símbolo estipula la existencia de riesgos de lesiones, así también como la posibilidad de daños físicos, si el producto llega a operarse incorrectamente ignorándose esta indicación.

Símbolos típicos



Este símbolo indica una advertencia adicional (incluyendo precauciones). Para aclarar la advertencia, se provee una ilustración.



Este símbolo indica una acción que no se debe realizar. Las indicaciones que figuran dentro o cerca de este símbolo están específicamente prohibidas (el ejemplo de la izquierda indica que el desarmado está prohibido).



Este símbolo indica una acción que debe ser realizada. Las indicaciones que figuran dentro o cerca de este símbolo están específicamente instruidas para ser realizadas (el ejemplo de la izquierda indica que la clavija de alimentación debe ser desconectada del tomacorriente).

ESPAÑOL



Discount-Merchant.com (800) 281-8860
THE TRUSTED SOURCE FOR PROJECTOR LAMPS AND ACCESSORIES

PRECAUCIONES DE SEGURIDAD

ADVERTENCIA

No utilice nunca el proyector cuando haya algún problema.

La operación en condiciones anormales tales como emisión de humos, olores extraños, ausencia de imagen, ausencia de sonido, sonido excesivo, daños en la carcasa, cables o elementos, entrada de líquidos o cuerpos extraños, etc., puede ocasionar incendio o descargas eléctricas. Si se produce alguna anomalía, apague el proyector inmediatamente y desenchufe la clavija de alimentación del tomacorriente. Después de confirmar que ha dejado de salir humo u olores extraños, póngase en contacto con su distribuidor. No intente realizar la reparación por su cuenta, pues podría resultar peligroso.

* Procure que el tomacorriente esté cerca del proyector y que sea fácilmente accesible.



Desenchufar la clavija de alimentación del tomacorriente.

No introduzca líquidos ni cuerpos extraños.

La entrada de líquidos o cuerpos extraños puede ocasionar incendio o descargas eléctricas.

Preste especial atención cuando hayan niños en la casa.

Si llegara a entrar líquido o cuerpos extraños dentro del proyector, apáguelo inmediatamente, desenchufe la clavija de alimentación del tomacorriente y póngase en contacto con su distribuidor.

* No instale el proyector en un cuarto de baño.

* No exponga el proyector a la lluvia o la humedad.

* No coloque floreros, macetas, vasos, cosméticos, ni nada que contenga agua u otros líquidos cerca de este proyector.

* No ponga objetos de metal, sustancias combustibles, etc., sobre o alrededor del proyector.



No efectúe ninguna modificación.

El proyector alberga componentes de alto voltaje. La modificación puede ocasionar incendio o descargas eléctricas.

* No abra nunca la carcasa.

* Deje que su distribuidor realice las tareas de reparación y limpieza interior.



No desarmar.

No aplique golpes ni impactos al proyector.

Un proyector golpeado y/o dañado puede ocasionar lesiones, y el uso en tales condiciones puede ocasionar incendio o descargas eléctricas. Si llegara a aplicar algún golpe al proyector, apáguelo inmediatamente, desconecte la clavija de alimentación del tomacorriente y póngase en contacto con su distribuidor.



ADVERTENCIA

No coloque el proyector sobre una superficie inestable.

Si el proyector llegara a caerse y/o dañarse, podría ocasionar lesiones, y el uso en tales condiciones podría provocar incendio o descargas eléctricas.

- * No coloque este proyector sobre una superficie inestable, desnivelada o insegura como por ejemplo una mesa tambaleante o inclinada.
- * Cuando instale este proyector sobre una mesa con ruedecillas, asegúrese de utilizar los topes de freno de las ruedecillas.
- * No ponga el proyector con su lateral hacia arriba, o con el objetivo hacia arriba o hacia abajo.



Preste atención al aumento de la temperatura del proyector.

Se generan altas temperaturas cuando la lámpara está encendida. Esto puede producir incendio o quemaduras. Preste especial atención en presencia de niños. Para evitar quemaduras, no toque el objetivo, los ventiladores de aire o las rejillas de ventilación durante o inmediatamente después del uso. Preste atención a la ventilación.

- * Mantenga un espacio de 30 cm o más entre los laterales y otros objetos o las paredes.
- * No coloque el proyector sobre una mesa metálica.
- * No ponga nada cerca del objetivo, los ventiladores de aire y las rejillas de ventilación del proyector.
- * No bloquee nunca los ventiladores de enfriamiento ni las rejillas de ventilación.
- * Evite el uso con las rendijas de ventilación dirigidas hacia abajo.
- * No cubra el proyector con un mantel, etc.
- * No coloque el proyector sobre una alfombra o un colchón.



No mire nunca a través del objetivo o de las rejillas de ventilación cuando la lámpara está encendida.

La luz potente podría dañar la vista. Preste especial atención en presencia de niños.



Utilice únicamente el tomacorriente correcto.

El uso de una fuente de alimentación incorrecta puede producir incendio o descargas eléctricas. Utilice únicamente la fuente de alimentación indicada en el proyector y observe las normas de seguridad.

- * Utilice el cordón de alimentación adjunto dependiendo del tomacorriente que se va a utilizar.



Tenga cuidado con la conexión del cable de alimentación.

La conexión incorrecta del cordón de alimentación puede producir incendio o descargas eléctricas.

- * No toque el cordón de alimentación con las manos mojadas.
- * Antes del uso, verifique que no haya suciedad (ni polvo) en la parte de conexión del cordón de alimentación. Para limpiar la clavija de alimentación, utilice un paño suave y seco.
- * Inserte firmemente la clavija de alimentación en el tomacorriente. Evite las conexiones flojas, defectuosas o inseguras.



PRECAUCIONES DE SEGURIDAD (continuación)

ADVERTENCIA

Preste atención al manejo de la lámpara de luminosidad.

Un manejo incorrecto de la lámpara puede producir una explosión.

- * Puesto que la lámpara está hecha de vidrio, evite los golpes y las rayaduras.
- * Para reemplazar la lámpara, apague el proyector, extraiga el cable de CA, y espere 45 minutos hasta que la lámpara se enfríe. Cuando la lámpara de alta presión está caliente, puede explotar si se manipula indebidamente.
- * La lámpara tiene una duración de vida de servicio útil. Para mayor información, consulte el manual del usuario. Para el reemplazo, póngase en contacto con su distribuidor o con un establecimiento de servicio técnico. No utilice una lámpara usada. Esto también podrá producir la explosión de la lámpara.



Tenga cuidado con el manejo del cordón de alimentación y de los cables de conexión externos.

El uso de un cordón de alimentación o cables de conexión dañados puede provocar incendio o descargas eléctricas. No aplique demasiado calor, presión o tensión al cordón de alimentación y a los cables.

Póngase en contacto con su distribuidor cuando haya algún cable o cordón de alimentación dañado (deshilachado, hilos al descubierto, etc.).

- * No coloque el proyector u otros objetos pensados encima del cordón de alimentación o de los cables de conexión. Asimismo, no coloque ninguna colcha, cubierta, etc., encima del mismo pues alguien podría colocar inadvertidamente objetos pesados encima del cordón de alimentación y de los cables.
- * No tire del cordón de alimentación y de los cables. Para la conexión o desconexión, tire de la clavija o de los conectores.
- * No coloque el cordón cerca de un calefactor.
- * Evite doblar bruscamente el cordón de alimentación.
- * No intente modificar el cordón de alimentación.



Tenga cuidado con el manejo de pila del mando a distancia.

Un manejo incorrecto de la pila puede producir incendio o lesiones. Si no la maneja correctamente, la pila puede explotar.

- * Mantenga la pila alejada de los niños y animales. Si llegara a ser ingerida, consulte inmediatamente con un médico para un tratamiento de emergencia.
- * No arroje la pila al fuego o al agua.
- * Evite los lugares donde existan llamas abiertas o de altas temperaturas.
- * No sujete la pila con pinzas metálicas.
- * Guarde la pila en un sitio oscuro, fresco y seco.
- * No ponga la pila en cortocircuito.
- * No recargue, desarme ni suelde la pila.
- * No aplique golpes a la pila.
- * Utilice únicamente la pila indicada en el manual del usuario.
- * Al instalar la pila, asegúrese de que los terminales positivo y negativo estén correctamente alineados.
- * Si la pila se sulfata, limpie el líquido derramado y cambie la pila. Si llegara a adherirse líquido a su cuerpo o su vestimenta, lave con abundante cantidad de agua.
- * Respete las leyes locales sobre la disposición de las pilas usadas.



PRECAUCIONES DE SEGURIDAD (continuación)

PRECAUCIÓN

Tenga cuidado al mover el proyector.

Cualquier negligencia puede producir daños personales o materiales.

- * No mueva el proyector durante el uso. Antes de moverlo, desconecte el cordón de alimentación y todas las conexiones externas, y deslice la puerta deslizante del objetivo.
- * No aplique golpes ni impactos al proyectos.
- * Para trasladarlo, utilice la bolsa para el transporte, de proveerse, dependiendo del manual de la bolsa de transporte.



No coloque nada encima del proyector.

La colocación de objetos pesados podría provocar una pérdida de equilibrio y la caída del proyector, causando daños personales o materiales. Preste especial atención cuando hayan niños en la casa.



Evite los lugares húmedos o polvorientos.

No instale este proyector en un sitio húmedo, polvoriento o expuesto a humos grasos o gases corrosivos, pues podrá resultar en incendio o descargas eléctricas.

- * Evite la instalación cerca de la cocina, un deshumidificador o en cualquier otro sitio expuesto a humedad o humos grasos.



Evite los lugares de altas temperaturas.

El calor podría tener efectos adversos sobre la carcasa del proyector y otros elementos. No coloque el proyector, el mando a distancia y otros elementos a la luz directa del sol o cerca de objetos que emitan calor, como calefactor, etc.



Desenchufe el cordón de alimentación para una desconexión completa.

- * Para fines de seguridad, desconecte el cordón de alimentación cuando no vaya a utilizar el proyector por un tiempo prolongado.
- * Antes de la limpieza, apague el proyector y desenchúfelo. La negligencia puede resultar en incendio o descargas eléctricas.



Desenchufar la clavija de alimentación del tomacorriente.

Solicite a su distribuidor la limpieza del interior del proyector una vez cada dos años.

La acumulación de polvo en el interior del proyector puede provocar incendio o días de funcionamiento. Se obtendrán mejores resultados si la limpieza se realiza antes de cada época de alta humedad, como las épocas de lluvia, etc.

- * No intente realizar la limpieza por su cuenta debido a que puede resultar peligroso.



ESPAÑOL

PRECAUCIONES DE SEGURIDAD (continuación)

NOTA

Evite aplicar golpes al mando a distancia.

Los golpes pueden provocar daños o fallos de funcionamiento del mando a distancia.

- * Procure no dejar caer el mando a distancia.
- * No coloque el proyector u otros objetos pesados encima del mando a distancia.

Tenga cuidado con el objetivo.

- * Cuando no esté usando el proyector, cierre la puerta deslizante del objetivo para proteger su superficie contra los arañazos.
- * No toque el objetivo para evitar que las huellas o la suciedad del objetivo deterioren la calidad de la imagen.
- * Para limpiar el objetivo, utilice un papel para limpiar objetivos (utilizado para limpiar cámaras, anteojos, etc.) disponible en las tiendas del ramo. Tenga cuidado de no rayar el objetivo con materiales abrasivos.

Limpie el filtro de aire aprox. cada 100 horas.

Cuando el filtro de aire esté obstruido por el polvo, etc., el proyector podría visualizar el mensaje "CHEQUEAR FLUJO DE AIRE" o apagarse, con el fin de evitar el aumento de la temperatura interior. Para permitir una buena ventilación, mantenga el filtro de aire en buenas condiciones.

- * No encienda el proyector sin haber instalado el filtro de aire.
- * Si el filtro de aire está dañado o se ha extraviado, pida a su distribuidor el filtro de aire especificado en el manual del usuario de su distribuidor.

Tenga cuidado con la carcasa y el mando a distancia.

Un cuidado incorrecto puede tener efectos perjudiciales como pérdida de color, descascarillado de la pintura, etc.

- * Utilice un paño suave para limpiar la carcasa y el panel de control del proyector y del mando a distancia. Cuando haya mucha suciedad, utilice un paño limpio y humedecido con detergente neutro diluido en agua, y luego seque con un paño seco. No aplique directamente detergente sin diluir.
- * No utilice pulverizadores en aerosol, solventes, sustancias volátiles ni limpiadores abrasivos.
- * Antes de utilizar paños químicos, asegúrese de leer y de observar las instrucciones.
- * Evite el contacto prolongado con caucho o vinilo.



Discount-Merchant.com (800) 281-8860
THE TRUSTED SOURCE FOR PROJECTOR LAMPS AND ACCESSORIES

NOTA

Evite los rayos potentes.

Los rayos potentes (como los rayos directos del sol o de la luz ambiental) sobre los sensores del mando a distancia pueden hacer que el mando a distancia quede inoperante.

Evite las interferencias de radio.

Las radiointerferencias pueden causar la distorsión de imágenes o de sonido.

* Evite usar aparatos generadores de ondas radioeléctricas como teléfonos celulares, transceptores, etc., cerca del proyector.

Acerca de la característica de visualización.

Las condiciones de visualización del proyector (como color, contraste, etc.) dependen de las características de la pantalla, debido a que el proyector utiliza un panel de visualización de cristal líquido. Las condiciones de visualización pueden diferir de la visualización de CRT.

* No utilice una pantalla polarizada. Se pueden producir imágenes rojas.

Efectúe el encendido/apagado en el orden correcto.

Para evitar posibles averías, encienda/apague el proyector en el orden mencionado abajo, a menos que se especifique de otro modo.

* Encienda el proyector antes del ordenador o de la videograbadora.

* Apague el proyector después del ordenador o de la videograbadora.

Tenga cuidado con la fatiga visual.

Descanse sus ojos periódicamente.

Ajuste el volumen de sonido a un nivel adecuado para no molestar a los demás.

* De noche se recomienda mantener el volumen a un nivel bajo y cerrar las ventanas como consideración a sus vecinos.

Conexión con el ordenador notebook.



Cuando conecte con un ordenador notebook, ajuste la salida de la imagen exterior RGB a válida (ajuste de pantalla CRT o visualización simultánea de LCD y CRT).

Para mayor información, tenga a bien leer el manual de instrucciones del ordenador notebook.

ALVORENS GEBRUIK

Waarschuwingssymbolen

In deze gebruiksaanwijzing en op het apparaat zelf staan diverse symbolen vermeld, die u de juiste bediening tonen en u waarschuwen om schade en gevaar voor uzelf en anderen te voorkomen. De betekenis van deze symbolen wordt hieronder uitgelegd. Lees de beschrijving aandachtig door, om volledig kennis te nemen van de betekenis.

| | |
|--|--|
|  WAARSCHUWING | Dit symbool vergezelt aanwijzingen die u niet mag veronachtzamen, omdat onjuiste bediening hier gevaar voor verwonding of zelfs fatale ongelukken kan veroorzaken. |
|  LET OP | Dit symbool vergezelt aanwijzingen die u dient te volgen om gevaar voor schade of lichamelijk letsel te voorkomen. |

Toegepaste symbolen



Dit symbool vergezelt een aanvullende waarschuwing (of bedieningsaanwijzing). Hierbij geeft het teken in het midden de inhoud aan.



Dit symbool waarschuwt voor een handeling die verboden is. De inhoud wordt verduidelijkt door het teken in het midden (het voorbeeld links geeft aan dat demontage niet is toegestaan).



Dit symbool geeft een noodzakelijke handeling aan. De inhoud wordt verduidelijkt door het teken in het midden (het voorbeeld links geeft aan dat u de stekker uit het stopcontact moet trekken).



Discount-Merchant.com (800) 281-8860
THE TRUSTED SOURCE FOR PROJECTOR LAMPS AND ACCESSORIES

VEILIGHEIDSMATREGELLEN

WAARSCHUWING

Gebruik de projector nooit indien deze niet juist werkt.

Gebruik de projector niet als deze rook uitstoot, vreemd ruikt, als er geen beeld of geluid is of als het geluid te luid is, als de behuizing, kabels of andere onderdelen beschadigd zijn, of als er een vloeistof of voorwerp in het apparaat is terechtgekomen, want dit kan resulteren in brand of een elektrische schok. In zulke gevallen moet u de projector meteen uitschakelen en de stekker uit het stopcontact trekken. Controleer of de rook of geur stopt en neem dan contact op met uw dealer. Probeer het apparaat nooit zelf te repareren want dit kan bijzonder gevaarlijk zijn.

* Gebruik een stopcontact dat dicht bij de projector is en dat gemakkelijk bereikbaar is.



Trek de stekker uit het stopcontact.

Let op dat geen vloeistof of voorwerp in het inwendige terechtkomt.

Als vloeistoffen of voorwerpen in het inwendige terechtkomen, kan dit resulteren in brand of een elektrische schok. Wees vooral voorzichtig wanneer er kinderen in de buurt zijn.

Indien toch vloeistof of een voorwerp in de projector terechtkomt, moet u het apparaat meteen uitschakelen, de stekker uit het stopcontact trekken en contact opnemen met uw dealer.

- * Zet de projector niet in de badkamer.
- * Stel de projector niet aan regen of vocht bloot.
- * Zet geen bloemenvazen, planten, kopjes, make-up of vloeistoffen zoals water enz. op of dicht in de buurt van de projector.
- * Leg geen metalen of brandbare voorwerpen of andere gevaarlijke stoffen op of dicht in de buurt van de projector.



Breng geen wijzigingen in de projector aan.

In de projector zijn hoge spanningen aanwezig. Wijzigingen kunnen resulteren in brand of een elektrische schok.

- * Maak nooit de behuizing open.
- * Neem voor reparatie of reiniging van het inwendige van de projector contact op met uw dealer.



Niet demonteren.

Stel de projector niet aan stoten of schokken bloot.

Als de projector aan stoten of schokken wordt blootgesteld, kan deze beschadigd worden en eventueel letsel veroorzaken. Bovendien bestaat de kans op brand of een elektrische schok.

Als de projector gevallen is of iets dergelijks, moet u deze meteen uitschakelen, de stekker uit het stopcontact trekken en contact opnemen met uw dealer.



NERLANDS

WAARSCHUWING

Zet de projector niet op een onstabiele ondergrond.

Als de projector valt, kan deze beschadigd worden en eventueel letsel veroorzaken. Bovendien bestaat de kans op brand of een elektrische schok.

- * Zet de projector niet op een onstabiel, schuin of trillend oppervlak zoals een wankel of schuin aflopend tafeltje.
- * Vergrendel de zwenkwieltjes wanneer u de projector op een tafeltje met zwenkwieltjes plaatst.
- * Plaats de projector niet met de zijkant naar boven, de lens naar boven of de lens naar beneden.



Wees voorzichtig, de projector geeft veel hitte af.

Wanneer de lamp brandt, geeft de projector veel hitte af. Er bestaat kans op brand en u kunt zich verbranden. Wees vooral voorzichtig wanneer er kinderen in de buurt zijn.

Raak de lens, de ventilators en de ventilatieopeningen niet aan tijdens gebruik of meteen na gebruik, om verbranding te voorkomen. Zorg ervoor dat de ventilatie niet belemmerd wordt.

- * Houd ten minste 30 cm ruimte vrij tussen de zijkant van de projector en de muur e.d.
- * Zet de projector niet op een metalen tafeltje.
- * Plaats geen voorwerpen dicht bij de lens, de ventilators of de ventilatieopeningen van de projector.
- * Let op dat de ventilators en de ventilatieopeningen niet geblokkeerd worden.
- * Gebruik de projector niet met de ventilatieopeningen naar beneden gekeerd.
- * Leg geen tafelkleed e.d. over de projector.
- * Zet de projector niet op een vloerkleed of bed.



Kijk nooit in de lens of de openingen wanneer de lamp brandt.

Het sterke licht kan uw gezichtsvermogen beschadigen. Wees vooral voorzichtig wanneer er kinderen in de buurt zijn.



Gebruik de projector op de juiste stroomvoorziening.

Gebruik op de verkeerde stroomvoorziening kan resulteren in brand of een elektrische schok. De projector mag alleen worden aangesloten op een

stopcontact dat voldoet aan de stroomspecificaties die op het apparaat staan. Gebruik het juiste netsnoer voor het stopcontact waarop u de projector aansluit.



Sluit het netsnoer zorgvuldig aan.

Een verkeerde aansluiting van het netsnoer kan resulteren in brand of een elektrische schok.

- * Raak het netsnoer niet met natte handen aan.
- * Controleer of de stekker van het netsnoer schoon is (geen stof) voordat u deze aansluit. Gebruik een zacht, droog doekje om de stekker schoon te maken.
- * Steek de stekker stevig in het stopcontact. Gebruik een juist werkend, degelijk stopcontact.



WAARSCHUWING

Behandel de lichtbronlamp voorzichtig.

Bij een verkeerde behandeling van de lamp kan deze ontploffen.

- * Aangezien de lamp van glas is, mag u deze niet bekrassen of aan sterke schokken blootstellen.
- * Voordat u de lamp vervangt, schakelt u de projector uit en trekt dan het netsnoer uit het stopcontact. Wacht vervolgens 45 minuten om de lamp te laten afkoelen. Wanneer de lamp staat onder hoge druk heet is, kan deze bij verkeerde behandeling ontploffen.
- * De lamp heeft een beperkte levensduur. Zie de gebruiksaanwijzing voor nadere bijzonderheden. Neem contact op met uw dealer of servicecentrum voor een vervangingslamp. Gebruik de oude lamp niet opnieuw. De lamp zou kunnen ontploffen.



Behandel het netsnoer en de aansluitkabels voorzichtig.

Wanneer u een beschadigd netsnoer of een beschadigde aansluitkabel gebruikt, kan dit brand of een elektrische schok veroorzaken. Let erop dat het netsnoer en de aansluitkabels niet aan te grote hitte worden blootgesteld. Druk het snoer en de kabels niet klem en trek ze ook niet te strak.

Neem contact op met uw dealer als het netsnoer of de aansluitkabels beschadigd zijn (blootliggende of gebroken kerndraadjes e.d.).

- * Zet niet de projector of een ander zwaar voorwerp op het netsnoer of de aansluitkabels. Leg ook geen sprei, deken e.d. over het netsnoer of de kabels, want dan is het mogelijk dat u per ongeluk een zwaar voorwerp op het snoer of de kabels plaatst.
- * Trek niet aan het netsnoer of de aansluitkabels. Pak bij het aansluiten of losmaken van het netsnoer of de aansluitkabels altijd de stekker of plug met uw hand vast.
- * Leg het netsnoer niet in de buurt van een verwarming.
- * Zorg dat het netsnoer niet te sterk gebogen wordt.
- * Probeer nooit zelf reparaties aan het netsnoer uit te voeren.



Behandel de batterij van de afstandsbediening voorzichtig.

Een verkeerde behandeling van de batterij kan resulteren in brand of letsel. De batterij kan zelfs ontploffen indien deze niet juist wordt behandeld.

- * Houd de batterij uit de buurt van kinderen en huisdieren. Als de batterij wordt afgeslikt, moet u meteen de hulp van een arts inroepen voor spoedbehandeling.
- * Zorg dat de batterij niet in water of vuur terecht komt.
- * Vermijd omgevingen met een hoge temperatuur of open vuur.
- * Pak de batterij niet met een metalen pincet vast.
- * Bewaar de batterij op een donkere, koele en droge plaats.
- * Zorg dat u de batterij niet kortsluit.
- * Probeer de batterij niet op te laden, te demonteren of te solderen.
- * Stel de batterij niet aan harde schokken of stoten bloot.
- * Gebruik uitsluitend de batterij vermeld in de gebruiksaanwijzing.
- * Zorg er bij het aanbrengen van de batterij voor dat de plus en min in de juiste richting zijn gekeerd.
- * Als de batterij heeft gelekt, moet u de batterijhouder goed schoonmaken en de batterij vervangen. Als het poeder aan uw huid of kleding blijft hangen, moet u dit grondig met water afspoelen.
- * Volg de plaatselijke wetgeving voor het weggooien van gebruikte batterijen.



LET OP

Wees voorzichtig wanneer u de projector vervoert.

Wanneer u niet voorzichtig te werk gaat, kan letsel of beschadiging worden veroorzaakt.

- * Verplaats de projector niet tijdens gebruik. Alvorens u de projector verplaatst, maakt u het netsnoer en alle aansluitkabels los en schuift u het lenskapje dicht.
- * Let op dat u de projector niet aan een harde stoot of schok blootstelt.
- * Vervoer de projector in de draagtas, indien deze is bijgeleverd, overeenkomstig de aanwijzingen voor het gebruik van de draagtas.



Zet niets bovenop de projector.

Wanneer u iets bovenop de projector zet, kan de projector verschuiven of vallen met letsel of beschadiging tot gevolg. Wees vooral voorzichtig wanneer er kinderen in de buurt zijn.



Houd de projector uit de buurt van vochtige of stoffige plaatsen.

Wanneer u de projector in een vochtige of stoffige ruimte, of in een ruimte met vette rook e.d. zet, kan dit resulteren in brand of een elektrische schok.

- * Zet de projector niet in de keuken, bij een luchtbevochtigingsapparaat of op een andere plaats met hoge vochtigheid of vette rook.



Vermijd opstelling in een omgeving met hoge temperaturen.

De hitte kan een nadelige invloed hebben op de behuizing en de interne onderdelen van de projector. Stel de projector, de afstandsbediening en de andere onderdelen niet aan direct zonlicht bloot en houd ze uit de buurt van hittebronnen zoals een verwarmingsradiator e.d.



Trek de stekker uit het stopcontact wanneer de projector langere tijd niet wordt gebruikt.

- * Om veiligheidsredenen moet u de stekker uit het stopcontact trekken wanneer u de projector langere tijd niet denkt te gebruiken.
- * Voordat u de projector gaat schoonmaken, moet u deze uitschakelen en de stekker uit het stopcontact trekken. Dit om brand of een elektrische schok te voorkomen.



Trek de stekker uit het stopcontact.

Laat uw dealer iedere twee jaar het inwendige van de projector schoonmaken.

Opgehoopt stof in de projector kan resulteren in brand of een defect. U kunt het inwendige van de projector het beste laten schoonmaken iedere keer voordat een vochtig seizoen begint (bijv. de regentijd in tropische landen).

- * Maak het inwendige van de projector niet zelf schoon, want dit is gevaarlijk.



OPMERKINGEN

Stel de afstandsbediening niet aan schokken bloot.

Harde stoten of schokken kunnen resulteren in een defect of beschadiging van de afstandsbediening.

- * Laat de afstandsbediening niet vallen.
- * Zet niet de projector of een ander zwaar voorwerp op de afstandsbediening.

Verzorging van de lens.

- * Wanneer de projector niet gebruikt wordt, moet u het lenskapje dichtschuiven om krassen op de lens te voorkomen.
- * Raak de lens niet aan om vlekken of vuil op de lens te voorkomen, hetgeen resulteert in een minder goede beeldkwaliteit.
- * Gebruik een in de handel verkrijgbaar lensreinigingsdoekje om de lens schoon te maken (zoals een reinigingsdoekje voor cameralenzen, brillenglazen e.d.). Wees voorzichtig dat u geen krassen op de lens maakt.

Maak het luchtfilter na iedere 100 gebruiksuren schoon.

Wanneer het luchtfilter verstopt raakt met stof e.d., toont de projector de melding "CONTROLEER LUCHTSTROOM" of wordt de projector automatisch uitgeschakeld, om oververhitting van de inwendige onderdelen te voorkomen. In dat geval moet het luchtfilter worden schoongemaakt.

- * Schakel de projector niet in wanneer het luchtfilter niet is aangebracht.
- * Als het luchtfilter beschadigd is of kwijtgeraakt, moet u een nieuw luchtfilter bestellen. Zie gebruiksaanwijzing voor de gegevens van het vereiste filter.

Verzorging van de projector-behuizing en de afstandsbediening.

Bij een verkeerde behandeling kan verkleuren, afschilferen e.d. optreden.

- * Gebruik een zachte doek om de behuizing en het bedieningspaneel van de projector en de afstandsbediening schoon te maken. Voor het verwijderen van hardnekkig vuil kan een zachte doek bevochtigd met een mild reinigingsmiddel, verdund met water, worden gebruikt. Wring de doek goed uit voordat u begint en wrijf met een droge, zachte doek na. Gebruik geen onverdund reinigingsmiddel.
- * Gebruik geen aërosolsprays, oplosmiddelen, schuurmiddelen of andere bijtende reinigingsmiddelen.
- * Lees zorgvuldig de instructies op het reinigingsmiddel voordat u dit gebruikt.
- * Vermijd langdurig contact met rubber of vinyl.



Discount-Merchant.com (800) 281-8860
THE TRUSTED SOURCE FOR PROJECTOR LAMPS AND ACCESSORIES

OPMERKINGEN

Vermijd sterke lichtstralen.

Zorg dat geen sterke lichtstralen (zoals direct zonlicht of het licht van een sterke lamp) op de afstandsbedieningssensors vallen want dan zal de afstandsbediening niet werken.

Vermijd hoogfrequentstoringen.

Bij hoogfrequentstoringen kan het beeld of geluid worden aangetast.

* Vermijd het gebruik van een hoogfrequentgenerator zoals een mobiele telefoon, zendontvanger e.d. in de buurt van de projector.

Betreffende de weergavekwaliteit.

De weergavekwaliteit van de projector (zoals de kleur, het contrast enz.) wordt eveneens bepaald door de eigenschappen van het scherm, want de projector maakt gebruik van een LCD-paneel. Het weergavebeeld kan verschillen van het beeld voortgebracht door een beeldbuis.

*Gebruik geen gepolariseerd scherm, want dit kan een rood beeld geven.

Schakel de apparatuur in de juiste volgorde in en uit.

Om storingen te voorkomen, moet u de projector en de andere apparatuur in de onderstaande volgorde in- en uitschakelen, tenzij anders aangegeven.

* Schakel eerst de projector in en dan de computer of videorecorder.

* Schakel de projector pas uit nadat u de computer of videorecorder hebt uitgeschakeld.

Zorg dat u uw ogen niet te zeer belast.

Het verdient aanbeveling regelmatig een rustpauze in te lassen.

Stel de geluidsterkte niet te hoog in om overlast voor anderen te voorkomen.

*Stel de geluidsterkte zodanig in dat er geen overlast voor anderen wordt veroorzaakt.

Aansluiten op een notebook-computer

Bij het aansluiten op een notebook-computer moet de externe RGB beelduitgang worden ingeschakeld (instelling voor CRT display of gelijktijdig LCD en CRT display).

Zie de gebruiksaanwijzing van de notebook-computer voor verdere informatie.



Discount-Merchant.com (800) 281-8860
THE TRUSTED SOURCE FOR PROJECTOR LAMPS AND ACCESSORIES

FØR BRUK

Angående symbolene

Forskjellige symboler har blitt tatt i bruk i denne bruksanvisningen og på selve enheten for å sikre riktig bruk, og for å forhindre skade på brukeren, andre personer og eiendeler. Symbolenes betydninger beskrives i avsnittet nedenfor. Det er viktig å lese beskrivelsene av de forskjellige symbolenes betydning grundig og gjøre seg innforstått med deres betydning.



ADVARSEL

Dette symbolet indikerer informasjon som, dersom det ignoreres, kan resultere i skade på person eller i verste fall tap av menneskelig pga. uriktig håndtering.



FORSKING

Dette symbolet indikerer informasjon som, dersom det ignoreres, kan resultere i skade på person eller eiendeler pga. av uriktig håndtering.

Typiske symboler



Denne typen symbol indikerer en ytterligere advarsel (inklusive oppfordringer til varsomhet). En illustrasjon vises som forklaring på advarselens innhold.



Denne typen symbol indikerer en utilrådelig betjeningsmåte. Illustrasjonen i varselmerket viser betjeningsmåten som ikke må utføres (symbolet til venstre viser at enheten ikke må demonteres).



Denne typen symbol indikerer en bydende handling. Illustrasjonen i varselmerket viser betjeningsmåten som må utføres (symbolet til venstre viser at strømpluggen må frakoples stikkkontakten).



Discount-Merchant.com (800) 281-8860
THE TRUSTED SOURCE FOR PROJECTOR LAMPS AND ACCESSORIES

NORASK

SIKKERHETSREGLER

ADVARSEL

Bruk ikke prosjektøren hvis det oppstår problemer.

Unormale tilstander som f.eks. røyk, rar lukt, ikke noe bilde, ingen lyd, for mye lyd, ødelagt hus, elementer eller kabler, eller hvis væske eller andre fremmedlegemer har trengt inn i apparatet, etc., kan forårsake branntilløp eller elektrisk støt. Hvis noen av de ovennevnte tilstandene skulle forekomme, må apparatet slås av og støpslet trekkes ut av stikkkontakten. Når du er sikker på at det ikke lenger røyker eller lukter rart, må forhandleren kontaktes. Gjør aldri forsøk på å utføre reparasjoner selv, det medfører stor fare for liv.

* Stikkkontakten må være i nærheten av prosjektøren og lett tilgjengelig.



Frakople strømpluggen fra stikkkontakten.

Unngå at væske eller fremmedlegemer trenger inn i apparatet.

Hvis væske eller fremmedlegemer skulle trenge inn i apparatet, kan det forårsake branntilløp eller elektrisk støt.

Utvis stor varsomhet når barn er tilstede.

Hvis væske eller fremmedlegemer skulle trenge inn i prosjektøren, må strømmen slås av omgående, støpslet trekkes ut av stikkkontakten og forhandleren kontaktes.

* Prosjektøren må ikke plasseres i et badeværelse.

* Prosjektøren må ikke utsettes for regn eller fuktighet.

* Plasser ikke blomstervaser, potteplanter, kopper, kosmetikk, væske slik som vann, etc., oppå eller nær prosjektøren.

* Plasser ikke metall, brennbart materiale, etc., oppå eller nær prosjektøren.



Modifiser ikke prosjektøren.

Prosjektøren inneholder høyspenningskomponenter. Modifisering av apparatet kan resultere i branntilløp eller elektrisk støt.

* Åpne aldri kabinettet.

* Overlat eventuelle reparasjoner eller innvendig rengjøring til forhandleren.



Ikke demonter.

Utsett ikke prosjektøren for støt eller slag.

Hvis prosjektøren utsettes for slag og/eller ødelegges, kan det resultere i personskader, og fortsatt bruk kan føre til branntilløp eller elektrisk støt.

Skulle prosjektøren utsettes for slag, må strømmen slås av omgående, støpslet trekkes ut av stikkkontakten og forhandleren kontaktes.



Discount-Merchant.com (800) 281-8860
THE TRUSTED SOURCE FOR PROJECTOR LAMPS AND ACCESSORIES

ADVARSEL

Plasser ikke prosjektøren på et ustabil underlag.

Hvis prosjektøren skulle falle i gulvet og/eller ødelegges, kan det forårsake personskader og fortsatt bruk kan føre til branntilløp eller elektrisk støt.

- * Plasser ikke prosjektøren på et underlag som er ustabil, skjevt eller som vibrerer, f.eks. et vaklevorent eller skråstilt stativ.
- * Plasser prosjektøren på et stativ med trinser og sett bremsene på.
- * Ikke sett prosjektøren sidelengs, eller med linsen vendt oppover eller nedover.



Vær oppmerksom på prosjektørens høye temperatur.

Apparatet blir veldig varmt når lampen er tent. Det kan resultere i brann eller forbrenninger. Utvis stor varsomhet når det er barn tilstede.

Objektivet, viften og ventilasjonsåpninger må ikke berøres under eller like etter bruk, det kan forårsake forbrenninger. Sørg for god ventilasjon.

- * Se til at det er en klaring på minst 30 cm mellom prosjektøren og f.eks. vegger.
- * Plasser ikke prosjektøren på bord av metall.
- * Plasser ikke noe nær objektivet, viften og ventilasjonsåpningene.
- * Se til at ikke viften eller ventilasjonsåpningene blokkeres.
- * Må ikke brukes med ventilasjonsåpningen ned.
- * Dekk ikke til prosjektøren med en duk, e.l.
- * Plasser ikke prosjektøren på et gulvteppe eller sengetøy.



Se aldri gjennom objektivet eller åpninger når lampen er tent.

Det kraftige lyset er skadelig for øynene. Utvis spesielt stor varsomhet når det er barn tilstede.



Bruk korrekt voltspenning.

Feil voltspenning kan resultere i branntilløp eller elektrisk støt. Bruk bare den spenningen som er angitt prosjektøren og i sikkerhetsreglene.

- * Den vedlagte nettleddningen må brukes i samsvar med nettstrømmen som skal brukes.



Sørg for korrekt tilkøpling av nettleddningen.

Feilaktig tilkøpling kan resultere i branntilløp eller elektrisk støt.

- * Rør aldri nettleddningen med våte hender.

Kontroller at koplingsenden av ledningen er ren (støvfri), før bruk. Tørk støpslet med en myk og tørr klut.

- * Sett støpslet helt inn i stikkontakten. Unngå stikkontakter hvor fatningen er løs eller skadet på noen måte.



ADVARSEL

Behandle lyskildelampen forsiktig.

Uforsiktig behandling kan resultere i en eksplosjon.

- *Siden lampen er laget av glass, må den ikke utsettes for slag og riping.
- *Når lampen skal skiftes ut, slås apparatet av og nettledningen trekkes ut av stikkkontakten., vent 45 minutter til lampen er avkjølt. Lyspæren har høyt trykk når den er varm og kan eksplodere hvis den ikke håndteres korrekt.
- *Lampen har en viss levetid. Se brukerhåndboken for nærmere detaljer. Ta kontakt med forhandleren eller serviceverkstedet når lampen skal skiftes ut. Bruk ikke en gammel lampe, det kan også forårsake eksplosjon.



Behandle nettledningen og eventuelle eksterne koplingskabler varsomt.

Fortsatt bruk av en skadet nettledning eller kabler kan resultere i branntilløp eller elektrisk støt. Utsett ikke nettledningen eller kabler for sterk varme, trykk eller belastninger.

Hvis nettledningen eller kabler kommer til skade (viklingen blottlegges eller knekker, etc.), må forhandleren kontaktes.

- * Plasser ikke prosjektøren eller andre tunge gjenstander oppå nettledningen eller kablene. Legg heller ikke tepper, kluter, etc. oppå ledningen eller kablene da de kan bli vanskelig å få øye på og noen ved et uhell kan komme til å plassere tunge gjenstander oppå.
- * Dra ikke i nettledningen eller kablene for å få støpslet ut av stikkkontakten med trekk i selve støpslet.
- * Unngå at ledningen plasseres nær en varmekilde.
- * Unngå at nettledningen bøyes kraftig.
- * Demonter ikke nettledningen.



Behandle fjernkontrollens batteri varsomt.

Feilaktig behandling av batteriet kan resultere i branntilløp eller elektrisk støt. Batteriet kan eksplodere hvis det ikke behandles korrekt.

- * Hold barn og kjæledyr unna batteriet. Hvis batteriet skulle svelges, må lege kontaktes øyeblikkelig.
- * Batteriet må ikke utsettes for vann eller brennes.
- * Batteriet må ikke utsettes for flammer eller høye temperaturer.
- * Hold aldri batteriet ved hjelp av et metallpinsett.

Oppbevar batteriet på et kjølig, mørkt og tørt sted.

- * Kortslett ikke batteriet.
- * Batteriet må ikke gjenopplades, demonteres eller loddes.
- * Batteriet må ikke utsettes for slag.
- * Bruk bare det batteriet som er spesifisert i brukerhåndboken.
- * Se til at pluss- og minuspolene peker riktig vei ved innsetting av batteriet.
- * Hvis det oppdages batterilekkasje, må dette tørkes opp og batteriet skiftes ut. Ved søl av batterilekkasje på hud eller klær, skyll med rikelig med vann.
- * Følg gjeldende regelverk ved kassering av batteriet.



FORSKING

Utvis varsomhet ved flytting av prosjektøren.

Uforsvarlig håndtering kan resultere i en ulykke eller skader.

- * Flytt ikke prosjektøren under bruk. Før den eventuelt flyttes, må støpslet trekkes ut av stikkkontakten, alle kontakter koples fra og objektivhetten settes på.
- * Unngå at prosjektøren utsettes for slag eller støt.
- * Ved bæring, må eventuell vedlagt bæreseske brukes.



Sett ikke noe oppå prosjektøren.

Hvis det settes noe oppå prosjektøren, kan den komme til å velte og forårsake skader på personer og gjenstander. Vær spesielt forsiktig når det er barn tilstede.



Unngå fuktighet og støv.

Hvis prosjektøren plasseres på steder med høy fuktighet, mye støv, fettos eller korroderende gasser kan det resultere i branntilløp eller elektrisk støt.

- * Må ikke plasseres nær kjøkken, luftfukter eller andre steder hvor det fins fettos eller fuktighet.



Unngå omgivelser med høy temperatur.

Varme kan ha negativ innvirkning på prosjektørens kabinett og andre deler. Prosjektøren, fjernkontrollen eller andre deler må ikke utsettes for direkte sol eller andre varmekilder som f.eks. en varmeovn, etc.



Kople nettledningen fra hvis apparatet ikke skal brukes på en stund.

- * Av sikkerhetsmessige grunner, må nettledningen koples fra hvis prosjektøren ikke skal brukes på en lang stund.
- * Trekk støpslet ut av stikkkontakten før eventuell rengjøring. Hvis dette ikke gjøres kan det resultere i branntilløp eller elektrisk støt.



Frakople strømpluggen fra stikkkontakten.

Be forhandleren om å rengjøre prosjektøren innvendig hvert 2. år.

Hvis det samler seg støv og skitt inni prosjektøren kan det resultere i branntilløp eller funksjonssvikt. Innvendig rengjøring er mest effektiv hvis den utføres før årstid hvor det kan forventes mye regn eller fuktighet.

Rengjøringen må av sikkerhetsmessige årsaker ikke utføres av kunden selv.



NORASK

SIKKERHETSREGLER (forts.)

NB:

Utsett ikke fjernkontrollen for slag.

Hvis fjernkontrollen utsettes for slag kan det forårsake skader eller funksjonssvikt.

- * Se til at fjernkontrollen ikke faller i gulvet.
- * Plasser aldri prosjektøren eller andre gjenstander oppå fjernkontrollen.

Vedlikehold av objektivet.

- * Lukk objektivhetten så linsen ikke utsettes for riper når prosjektøren ikke er i bruk.
- * Ta ikke på selve linsen for å unngå at dugg og skitt reduserer visningskvaliteten.
- * Bruk en kommersielt tilgjengelig rensklut (til kameraer, briller, etc) til å rengjøre linsen med. Pass på at riper unngås.

Rens luftfilteret cirka hver 100. time.

Når luftfilteret stoppes til av støv og skitt, vil prosjektøren vise en melding som sier "SJEKK LUFTSTRØMMEN". Slå av prosjektøren for å unngå at den overopphetes. Sjekk deretter filteret ved å gå frem.

- * Slå ikke på prosjektøren uten at luftfilteret er påmonteret.
- * Hvis luftfilteret er skadet eller blitt borte, må nytt skaffes ved bestilling gjennom forhandleren. Se detaljer under brukerhåndboken.

Vedlikehold av kabinett og fjernkontroll.

Ved feilbehandling kan det forekomme misfarging, avskalling, etc.

- * Bruk en myk klut til å rengjøre prosjektørens kabinett og kontrollpanel og fjernkontrollen. Hvis delene er veldig skitne, tørkes de med en myk klut som er godt oppvridd i nøytralt rengjøringsmiddel. Bruk ikke ufortynnet rengjøringsmiddel direkte på prosjektøren eller andre deler.
- * Bruk ikke aerosolspray, løsemidler, flyktige væsker eller slipemidler.
- * Før eventuelt bruk av kjemiske rensmidler, må bruksanvisningen for slike midler leses nøye.
- * Unngå at gummi eller vinyl er i kontakt med utstyret over lenger tid.



Discount-Merchant.com (800) 281-8860
THE TRUSTED SOURCE FOR PROJECTOR LAMPS AND ACCESSORIES

SIKKERHETSREGLER (forts.)

NB:

Unngå sterke stråler.

All sterk bestråling som direkte sol eller rombelysning på fjernkontrollens sensor kan sette den ut av funksjon.

Unngå radiointerferens.

Enhver slags stråling kan forårsake interferens som forvrengte bilder og støy.

* Unngå generatorene som f.eks. mobiltelefoner, senderutstyr, etc., i nærheten av prosjektøren.

Litt om displayfunksjoner.

Prosjektørens displayfunksjoner (slik som farge, kontrast, etc) avhenger av skjermegenskapene siden prosjektøren benytter et LCD-panel. Displayforholdene er forskjellige fra CRT.

* Polariserte skjermer må ikke brukes, siden det kan forårsake at bildet blir rødlig.

Slå strømmen på/av i riktig rekkefølge.

For å unngå problemer må strømmen slås på i riktig rekkefølge med mindre annet er nevnt.

* Slå strømmen til prosjektøren på før PC'en eller videospilleren.

* Slå strømmen til prosjektøren av etter PC'en eller videospilleren.

Anstreng ikke øynene.

Hvil øynene med jevne mellomrom.

Still lyden inn på et nivå som ikke er til sjenanse for andre.

* Om kvelden bør lyden settes ned og vinduet lukkes så naboer ikke fortyrres.

Tilkopling med notisblokk datamaskin

Når det koples til med notisblokk datamaskin, still inn for å gjøre RGB eksternt bilde uttak gyldig (innstilling av CRT (bilderør) display, eller display til LCD (vindu av flytende krystall) og CRT samtidig.

Vennligst les instruksjonsheftet til notisblokken for mer informasjon.





Discount-Merchant.com (800) 281-8860
THE TRUSTED SOURCE FOR PROJECTOR LAMPS AND ACCESSORIES

NORASK

ANTES DE USAR

Sobre os símbolos

Vários símbolos são usados neste manual, no Manual do Usuário e no próprio produto para assegurar o uso correto, evitar riscos ao usuário e a outras pessoas, e prevenir danos a propriedades. Descreve-se abaixo o significado destes símbolos. É importante ler atentamente as descrições e compreender seu significado na íntegra.

| | |
|--|--|
|  ADVERTÊNCIA | Este símbolo indica informação que, se ignorada, acarreta risco de ferimentos ou até mesmo morte em consequência de manuseio inadequado. |
|  PRECAUÇÃO | Este símbolo indica informação que, se ignorada, acarreta risco de ferimentos ou danos materiais em consequência de manuseio inadequado. |

Símbolos comuns



Este símbolo indica advertência adicional (incluindo precauções). Uma ilustração é apresentada para facilitar a compreensão.



Este símbolo indica ação proibida. A ação estará claramente indicada por uma ilustração ou recurso similar (o símbolo à esquerda indica que é proibido desmontar o equipamento).



Este símbolo indica ação obrigatória. Os conteúdos serão indicados claramente em uma ilustração ou recurso similar (o símbolo à esquerda indica que o plugue de alimentação deve ser desconectado da tomada elétrica).



Discount-Merchant.com (800) 281-8860
THE TRUSTED SOURCE FOR PROJECTOR LAMPS AND ACCESSORIES

PRECAUÇÕES DE SEGURANÇA

ADVERTÊNCIA

Nunca use o projetor se ocorrer algum problema com o aparelho.

Há risco de incêndio ou choque elétrico se o aparelho for operado em condições anormais, como de emissão de fumaça ou odor estranho; de falta de imagem ou de som; de som excessivamente alto; ou quando sua superfície externa, componentes ou cabos estiverem danificados; quando líquidos ou matéria estranha tiverem penetrado no aparelho, etc.

Nestes casos, desligue imediatamente o aparelho através da chave liga-desliga e desconecte o plugue de alimentação da tomada elétrica. Depois de se certificar da inexistência de fumaça ou odor, entre em contato com o revendedor do aparelho. Nunca tente consertar o aparelho por conta própria, pois seria perigoso.

* A tomada elétrica deve estar próxima do projetor e facilmente acessível.



Desconecte o plugue da tomada elétrica.

Líquidos ou objetos estranhos não devem penetrar no aparelho.

A penetração de líquidos ou objetos estranhos no aparelho poderá resultar em incêndio ou choque elétrico.

Tome cuidado especial quando houver crianças no ambiente.

Se líquidos ou objetos estranhos penetrarem no projetor, desligue-o imediatamente através da chave liga-desliga, desconecte o plugue de alimentação da tomada elétrica e entre em contato com o revendedor do aparelho.

* Não coloque o projetor em banheiros.

* Não exponha o projetor à chuva ou a umidade.

* Não coloque vasos de flores, panelas, xícaras, cosméticos, água ou outros líquidos, etc. sobre o projetor ou próximo dele.

* Não coloque metais, combustíveis, etc. sobre o projetor ou próximo dele.



Nunca modifique o aparelho.

O projetor contém componentes de alta voltagem. Modificações poderão resultar em incêndio ou choque elétrico.

* Nunca abra o gabinete.

* Solicite consertos e limpeza interna ao revendedor do aparelho.



Não desmonte.

Não submeta o projetor a choque ou impacto.

Se o projetor for submetido a choque e/ou se quebrar, poderá causar ferimentos, seu uso continuado nesta condição poderá resultar em incêndio ou choque elétrico.

Se o projetor for submetido a choque, desligue-o imediatamente através da chave liga-desliga, desconecte o plugue de alimentação da tomada elétrica e entre em contato com o revendedor do aparelho.

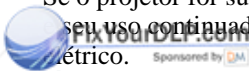

DISCOUNT WORLD TRADING COMPANY 011 281-886
THE TRUSTED SOURCE FOR PROJECTOR LAMPS AND ACCESSORIES

PORTGÊS

ADVERTÊNCIA

Não coloque o projetor em base instável.

Se o projetor cair ao chão e/ou se quebrar, poderá causar ferimentos, e seu uso continuado nesta condição poderá resultar em incêndio ou choque elétrico.

- * Não coloque o projetor em base instável, inclinada ou vibratória, como estante pouco firme ou inclinada.
- * Se colocar o projetor em uma estante com rodinhas, acione a trava das rodinhas.
- * Não posicione o projetor de cristal líquido com uma de suas laterais voltada para cima, com a lente voltada para cima ou com a lente voltada para baixo.



Cuidado com as temperaturas elevadas do projetor.

A lâmpada do projetor, quando acesa, gera temperaturas elevadas, capazes de dar origem a incêndio ou queimaduras. Tome cuidado especial quando houver crianças no ambiente.

Para evitar queimaduras, não toque na lente, ventiladores e aberturas de ventilação durante o uso ou imediatamente após o uso. Providencie ventilação adequada.

- * Deixe um espaço de 30 cm ou mais entre as laterais do aparelho e outros objetos ou paredes.
- * Não coloque o projetor em cima de mesas metálicas.
- * Não coloque nada próximo da lente, dos ventiladores e das aberturas de ventilação do projetor.
- * Nunca bloqueie o ventilador ou as aberturas de ventilação.
- * Não utilize o aparelho com a abertura de ventilação voltada para baixo.
- * Não cubra o projetor com toalha de mesa, etc.
- * Não coloque o projetor sobre tapete ou roupa de cama.



Nunca olhe através da lente ou das aberturas quando a lâmpada estiver ligada.

A potente iluminação pode afetar adversamente a visão. Tome cuidado especial quando houver crianças no ambiente.



Use sempre a tomada elétrica correta.

Uma alimentação elétrica inadequada poderá resultar em incêndio ou choque elétrico. Use sempre a tomada elétrica correta, de acordo com a indicação afixada no projetor e dentro do padrão de segurança.

- * O cabo de alimentação fornecido deve corresponder à tomada elétrica a ser utilizada.



Conecte adequadamente o cabo de alimentação.

Uma conexão incorreta do cabo de alimentação poderá resultar em incêndio ou choque elétrico.

- * Não toque no cabo de alimentação com a mão molhada.
- * Certifique-se de que a extremidade de conexão do cabo de alimentação esteja limpa (sem poeira) antes de sua utilização. Use um pano macio e seco para limpar o plugue de alimentação.
- * Introduza o plugue de alimentação com firmeza na tomada elétrica. Evite usar uma tomada frouxa, defeituosa, que possa gerar falha de contato.



ADVERTÊNCIA

Manuseie com cuidado a lâmpada de fonte luminosa.

Um manuseio inadequado da lâmpada pode dar origem a explosão.

- * Como a lâmpada é feita de vidro, não submeta-a a choque nem a arranhões.
- * Ao substituir a lâmpada, desligue e remova o cabo de alimentação de AC, e aguarde 45 minutos para deixar a lâmpada resfriar. Em alta pressão, quando aquecida, a lâmpada pode explodir se for manuseada indevidamente.
- * A lâmpada tem um período de duração limitado. Leia detalhes no manual do usuário. Entre em contato com o revendedor do aparelho ou com a companhia de assistência técnica para substituição da lâmpada. Não use lâmpadas velhas, pois há risco de explosão.



Tenha cuidado ao manusear os cabos de alimentação e conexão externa.

Se os cabos de alimentação e conexão estiverem danificados, seu uso continuado poderá dar origem a incêndio ou choque elétrico. Não aplique excessivos calor, pressão ou tensão aos cabos de alimentação e conexão.

Se os cabos de alimentação e conexão estiverem danificados (fios internos expostos ou quebrados, etc.), entre em contato com o revendedor do aparelho.

- * Não coloque o projetor ou outros objetos pesados em cima dos cabos de alimentação e conexão. Não coloque tampouco nenhuma cobertura, capa, etc. em cima dos cabos de alimentação e conexão, pois o encobrimento dos cabos poderá resultar na colocação inadvertida de objetos pesados sobre eles.
- * Não puxe os cabos de alimentação e conexão. Para conectar ou desconectar os cabos de alimentação e conexão, segure o plugue ou o conector dos cabos.
- * Não coloque os cabos perto de aquecedores.
- * Evite formar dobras acentuadas no cabo de alimentação.
- * Procure não trabalhar sobre o cabo de alimentação.



Manuseie cuidadosamente a pilha do controle remoto.

Um manuseio inadequado da pilha poderá resultar em incêndio ou ferimentos. A pilha poderá explodir se não for manuseada adequadamente.

- * Mantenha a pilha longe de crianças e de animais de estimação. Se ocorrer ingestão acidental da pilha, consulte imediatamente um médico para tratamento de emergência.
- * Não coloque a pilha no fogo ou água.
- * Evite o fogo ou ambientes com temperatura elevada.
- * Não segure a pilha com pinças metálicas.
- * Mantenha a pilha em local escuro, fresco e seco.
- * Não ponha a pilha em curto-circuito.
- * Não recarregue, desmonte nem solde a pilha.
- * Não submeta a pilha a impacto físico.
- * Use somente a pilha especificada na Manual do Usuário.
- * Certifique-se de que os pólos positivo e negativo estejam na posição correta ao instalar a pilha.
- * Se constatar vazamento da pilha, remova a oxidação e troque a pilha. Se a oxidação aderir a seu corpo ou roupas, remova bem com água.
- * Obedeça às leis locais sobre o descarte de pilhas.



Downloaded from www.projector-lamp.com (800) 281-8866
THE TRUSTED SOURCE FOR PROJECTOR LAMPS AND ACCESSORIES

PRECAUÇÕES DE SEGURANÇA (continuação)

PRECAUÇÃO

Tenha cuidado ao mover o projetor.

Deixar de tomar estas precauções poderá resultar em ferimentos ou danos.

Σ Não mova o projetor durante o uso. Antes de mover o aparelho, desconecte o cabo de alimentação e todas as conexões externas, e feche a porta deslizante da lente.

* Evite submeter o projetor a qualquer impacto ou choque.

* Para transportar o aparelho, use a bolsa de transporte, se fornecida, de acordo com o manual específico da bolsa de transporte.



Não coloque nada em cima do projetor.

A colocação de qualquer objeto em cima do projetor poderá resultar em perda de equilíbrio ou queda, com risco de ferimentos ou danos. Tome cuidado especial quando houver crianças no ambiente.



Evite locais úmidos ou poeirentos.

A colocação do projetor em local com intensa umidade, poeira, fuligem gordurosa ou gás corrosivo poderá resultar em incêndio ou choque elétrico.

* Não coloque o aparelho perto de cozinhas, umidificadores ou em outro locais onde haja fumaça gordurosa ou umidade.



Evite ambientes com temperatura elevada.

O calor pode produzir efeitos adversos no gabinete do projetor e em outras partes. Não coloque o projetor, o controle remoto e outras partes sob luz solar direta ou perto de objetos quentes, como aquecedores, etc.



Remova o cabo de alimentação para assegurar uma desconexão completa.

* Por razões de segurança, desconecte o cabo de alimentação se não for usar o projetor por longos períodos de tempo.

* Antes de limpar o projetor, desligue-o e remova o plugue da tomada. Deixar de tomar esta precaução poderá resultar em incêndio ou choque elétrico.



Desconecte o plugue da tomada elétrica.

Solicite ao revendedor do aparelho uma limpeza interna do projetor a cada dois anos.

acumulação de pó no interior do projetor poderá resultar em incêndio ou mau funcionamento.

Limpezas internas serão mais eficazes se realizadas antes de períodos úmidos, como épocas de chuvas intensas.

* Não limpe o aparelho internamente pois é perigoso.



NOTAS

Não submeta o controle remoto a nenhum impacto físico.

Impactos físicos poderão causar dano ou mau funcionamento do controle remoto.

- * Tome cuidado para não deixar cair o controle remoto.
- * Não coloque o projetor ou objetos pesados em cima do controle remoto.

Cuidados com a lente.

- * Feche a porta deslizante da lente para evitar que a superfície de lente sofra arranhões quando o projetor não for utilizado.
- * Não toque na lente de modo a evitar que obscurecimento ou sujeira cause deterioração da qualidade de exibição.
- * Para limpar a lente, use lenços de limpeza à venda no comércio (para limpeza de máquinas fotográficas, óculos, etc.). Tenha cuidado para não arranhar a lente com objetos ásperos.

Limpe o filtro de ar a cada 100 horas.

Se o filtro de ar ficar impregnado de pó, etc., o projetor poderá exibir uma mensagem semelhante a "VERIFIQUE O FLUXO DE AR" ou até mesmo se desligar automaticamente para evitar a elevação do nível de aquecimento interno. Para restaurar a ventilação normal, limpe o filtro de ar.

- * Não ligue o projetor sem o filtro de ar.
- * Se danificar ou extraviar o filtro de ar, solicite ao revendedor do projetor o filtro de ar especificado na Manual do Usuário .

Cuidados com o gabinete e o controle remoto.

Cuidados inadequados poderão produzir efeitos adversos, como descoloração, descascamento da pintura, etc.

- * Use um pano macio para limpar o gabinete e o painel de controle do projetor, e o controle remoto. Se a sujeira for excessiva, dilua detergente neutro em água, molhe e torça um pano macio para a limpeza. Em seguida, enxugue com um pano macio seco. Não use diretamente detergente não diluído em água.
- * Não use sprays aerossóis, solventes, substâncias voláteis ou limpadores abrasivos.
- * Se usar substâncias químicas de limpeza, certifique-se de ler e obedecer às instruções.
- * Não mantenha em contato direto com borracha ou plástico por longo tempo.



Discount-Merchant.com (800) 281-886
THE TRUSTED SOURCE FOR PROJECTOR LAMPS AND ACCESSORIES

PORTGÊS

PRECAUÇÕES DE SEGURANÇA (continuação)

NOTAS

Evite raios fortes.

Qualquer incidência de raios fortes (como raios diretos do sol ou iluminação artificial) sobre os sensores de controle remoto poderá inutilizar o controle remoto.

Evite interferências de rádio.

Qualquer irradiação de interferência poderá causar distorção da imagem ou ruídos.

* Evite o uso de aparelhos que emitem ondas de rádio, como telefones celulares, transreceptores, etc. nas proximidades do projetor.

Sobre características de exibição.

As condições de exibição do projetor (como cor, contraste, etc.) dependem das características da tela, visto que o projetor emprega um painel de cristal líquido. As condições de exibição podem diferir das propiciadas por tubos de raios catódicos.

* Não use tela polarizada, que poderá produzir imagem vermelha.

Ligue e desligue a alimentação na ordem correta.

Para evitar dificuldades, ligue/desligue o projetor na ordem correta descrita abaixo, salvo se houver determinação em sentido contrário.

* Ligue o projetor antes do computador ou do gravador de videocassete.

* Desligue o projetor depois do computador ou do gravador de videocassete.

Cuidado para não ficar com a vista cansada.

Descanse a vista periodicamente.

Mantenha o volume do som em nível satisfatório para não importunar outras pessoas.

* Convém manter baixo o nível de volume e fechar as janelas à noite para assegurar um ambiente tranqüilo na vizinhança.

Conexão com computador tipo “notebook”

Ao conectar com computador tipo “notebook”, configure para válida a saída de imagem externa RGB (selecionando monitor CRT ou monitores simultâneos de LCD e CRT).

Leia maiores detalhes no manual de instruções do computador tipo “notebook”.



Discount-Merchant.com (800) 281-8860
THE TRUSTED SOURCE FOR PROJECTOR LAMPS AND ACCESSORIES



Discount-Merchant.com (800) 281-8860
THE TRUSTED SOURCE FOR PROJECTOR LAMPS AND ACCESSORIES



Discount Merchant.com (800) 281-8860

THE TRUSTED SOURCE FOR PROJECTOR LAMPS AND ACCESSORIES



QR46291W

QR46291

Printed in Japan



Disclaimer

This user manual is provided as a free service by FixYourDLP.com. FixYourDLP is in no way responsible for the content of this manual, nor do we guarantee its accuracy. FixYourDLP does not make any claim of copyright and all copyrights remain the property of their respective owners.

About FixYourDLP.com

FixYourDLP.com (<http://www.fixyourdpl.com>) is the World's #1 resource for media product news, reviews, do-it-yourself guides, and manuals.

Informational Blog: <http://www.fixyourdpl.com>

Video Guides: <http://www.fixyourdpl.com/guides>

User Forums: <http://www.fixyourdpl.com/forum>

FixYourDLP's Fight Against Counterfeit Lamps:

<http://www.fixyourdpl.com/counterfeits>

Sponsors:

RecycleYourLamp.org – Free lamp recycling services for used lamps:

<http://www.recycleyourlamp.org>

Lamp Research - The trusted 3rd party lamp research company:

<http://www.lampresearch.com>

Discount-Merchant.com – The worlds largest lamp distributor:

<http://www.discount-merchant.com>



FixYourDLP.com

Sponsored by 