



Disclaimer

This user manual is provided as a free service by FixYourDLP.com. FixYourDLP is in no way responsible for the content of this manual, nor do we guarantee its accuracy. FixYourDLP does not make any claim of copyright and all copyrights remain the property of their respective owners.

About FixYourDLP.com

FixYourDLP.com (<http://www.fixyourdpl.com>) is the World's #1 resource for media product news, reviews, do-it-yourself guides, and manuals.

Informational Blog: <http://www.fixyourdpl.com>

Video Guides: <http://www.fixyourdpl.com/guides>

User Forums: <http://www.fixyourdpl.com/forum>

FixYourDLP's Fight Against Counterfeit Lamps:

<http://www.fixyourdpl.com/counterfeits>

Sponsors:

RecycleYourLamp.org – Free lamp recycling services for used lamps:

<http://www.recycleyourlamp.org>

Lamp Research - The trusted 3rd party lamp research company:

<http://www.lampresearch.com>

Discount-Merchant.com – The worlds largest lamp distributor:

<http://www.discount-merchant.com>



FixYourDLP.com

Sponsored by 



INSTALLATION/OPERATION MANUAL



VX-3000

1080p DLP™ Home Theater Projector



Discount-Merchant.com (800) 281-8860
THE TRUSTED SOURCE FOR PROJECTOR LAMPS AND ACCESSORIES



THE WORLD'S FINEST HOME THEATER PRODUCTS™



Discount-Merchant.com (800) 281-8860
THE TRUSTED SOURCE FOR PROJECTOR LAMPS AND ACCESSORIES

TWO YEAR LIMITED WARRANTY

For Projectors, Video Processors and Controllers
from Runco International, LLC (“Runco”)

Congratulations on your purchase of a Runco video product and welcome to the Runco family! With proper installation, setup and care, you should enjoy many years of unparalleled video performance.

This is a LIMITED WARRANTY as defined in the Magnuson-Moss Warranty Act. Please read it carefully and retain it with your other important documents.

WHAT IS COVERED UNDER THE TERMS OF THIS LIMITED WARRANTY:

The following Runco product models are covered under this Limited Warranty:
VX-3000 (“Product” individually and “Products” collectively).

SERVICE LABOR: Runco will pay for service labor at an Authorized Service Center when needed as a result of manufacturing defect for a period of two (2) years from the date of delivery to the initial end user (excluding the lamp).

PARTS (not including the lamp): Runco will provide new or rebuilt replacement parts for the parts that fail due to defects in materials or workmanship for a period of two (2) years from the effective date of delivery to the initial end user. Such replacement parts are then subsequently warranted for the remaining portion (if any) of the original warranty period.

PROJECTOR LAMP: Runco will pay for service labor at an Authorized Service Center when needed as a result of a manufacturing defect for a period of six (6) months or 1000 hours, whichever comes first, from the effective date of delivery to the initial end user. In addition, Runco will provide a new or rebuilt replacement lamp for the lamp that fails due to defects in materials or workmanship for a period of six (6) months or 1000 hours, whichever comes first, from the effective date of delivery to the initial end user. Such replacement parts are then subsequently warranted for the remaining portion (if any) of the original warranty period.

WHAT IS NOT COVERED UNDER THE TERMS OF THIS LIMITED WARRANTY:

This Limited Warranty only covers failure due to defects in materials and workmanship that occur during normal use and does not cover normal wear and tear nor any Product on which the serial number has been defaced, modified, or removed. This Limited Warranty does not cover: cabinets or any appearance items; failure resulting from accident, misuse, abuse, neglect, mishandling, misapplication, or faulty or improper installation or setup adjustments; improper maintenance; alteration; improper use of any input signal; damage due to lightning or power line surges, spikes and brownouts; damage that occurs during shipping or transit; damage that is attributed to acts of God; customer caused defects; or rental costs incurred due to Product failure. In the case of remote control units, damage resulting from leaking, old, damaged or improper batteries is also excluded from coverage under this Limited Warranty.

CAUTION: THIS LIMITED WARRANTY ONLY COVERS RUNCO PRODUCTS PURCHASED FROM AUTHORIZED RUNCO DEALERS. ALL OTHER PRODUCTS ARE SPECIFICALLY EXCLUDED FROM COVERAGE UNDER THIS WARRANTY. MOREOVER, DAMAGE RESULTING DIRECTLY OR INDIRECTLY FROM IMPROPER INSTALLATION OR SETUP IS SPECIFICALLY EXCLUDED FROM COVERAGE UNDER THIS LIMITED WARRANTY. IT IS IMPERATIVE THAT INSTALLATION AND SETUP WORK BE PERFORMED ONLY BY AN AUTHORIZED RUNCO DEALER TO PROTECT YOUR RIGHTS UNDER THIS WARRANTY. THIS WILL ALSO ENSURE THAT YOU ENJOY THE FINE PERFORMANCE OF WHICH YOUR RUNCO PRODUCT IS CAPABLE WHEN INSTALLED AND CALIBRATED BY AN AUTHORIZED RUNCO DEALER.

 **Discount-Merchant.com (800) 281-8860**
THE TRUSTED SOURCE FOR PROJECTOR LAMPS AND ACCESSORIES

RIGHTS, LIMITS AND EXCLUSIONS:

THE FOREGOING DESCRIBED WARRANTIES ARE THE ONLY WARRANTIES THAT APPLY TO THE PRODUCTS. RUNCO MAKES NO OTHER WARRANTY OR REPRESENTATION AND HEREBY DISCLAIMS ALL OTHER WARRANTIES, EXPRESS OR IMPLIED, INCLUDING, BUT NOT LIMITED TO, THE IMPLIED WARRANTIES OF MERCHANTABILITY AND FITNESS FOR A PARTICULAR PURPOSE. RUNCO'S LIABILITY RELATED TO THE PRODUCT IS LIMITED TO THE COST OF THE APPLICABLE REMEDY AS NOTED ABOVE. IN NO EVENT SHALL RUNCO BE LIABLE FOR:

- DAMAGE TO OTHER PROPERTY CAUSED BY ANY DEFECTS IN THE PRODUCT, DAMAGES BASED UPON INCONVENIENCE, LOSS OF USE OF THE PRODUCT, LOSS OF TIME, LOSS OF PROFITS, LOSS OF BUSINESS OPPORTUNITY, LOSS OF GOODWILL, INTERFERENCE WITH BUSINESS RELATIONSHIPS, OR OTHER COMMERCIAL LOSS, EVEN IF ADVISED OF THE POSSIBILITY OF SUCH DAMAGES;
- ANY OTHER DAMAGES, WHETHER INCIDENTAL, CONSEQUENTIAL OR OTHERWISE;
- ANY CLAIM AGAINST THE CUSTOMER BY ANY OTHER PARTY; OR
- ANY VERBAL WARRANTY ASSURANCES MADE BY A RUNCO EMPLOYEE OR A RUNCO AUTHORIZED DEALER THAT CONFLICTS WITH OR ENHANCES THE WRITTEN WARRANTY INCLUDED HEREIN.

EFFECTIVE WARRANTY DATE:

This Limited Warranty begins on the date of delivery to the end user. For your convenience, keep the original bill of sale as evidence of the purchase date.

CONTACT AN AUTHORIZED SERVICE CENTER TO OBTAIN SERVICE:

Repairs made under the terms of this Limited Warranty covering your VX-3000 Product will be performed at the location of the Product, during usual working hours, provided that the location of the Product is within normal operating distance from an Authorized Runco Service Center. In some instances it may be necessary for the Product to be returned to the Runco factory for repairs. If, solely in Runco's judgment, location of Product to be repaired is beyond normal operating distance of the closest Authorized Runco Service Center, or the repair requires the unit be returned to the Runco factory, it is the owner's responsibility to arrange for shipment of the Product for repair. These arrangements must be made through the selling Runco Dealer. If this is not possible, contact Runco directly for a Return Authorization number and shipping instructions. Runco will return Product with transportation prepaid in the United States, unless no Product defect is discovered. In that instance, shipping costs will be the responsibility of the Product owner.



Discount-Merchant.com (800) 281-8860
THE TRUSTED SOURCE FOR PROJECTOR LAMPS AND ACCESSORIES

COPYRIGHT AND TRADEMARKS:

© Copyright 2009 Runco International, LLC (“Runco”). This document contains proprietary information protected by copyright, trademark and other intellectual property laws. All rights are reserved. No part of this manual may be reproduced by any mechanical, electronic or other means, in any form, without prior written permission of Runco.

The trademarks reproduced in this Runco Owner’s Manual and used on the Runco Products are either owned by Runco or are licensed by Runco. You may not reproduce or use the trademarks without the prior written consent of Runco.

Runco Products are manufactured under one or more of the following patents: US. Patent 6755540 and Other Patents Pending.

ADDITIONAL INFORMATION:

To locate the name and address of the nearest Authorized Runco Service Center, or for additional information about this Limited Warranty, please call or write:

RUNCO INTERNATIONAL, LLC
1195 NW Compton Drive
Beaverton, OR 97006-1992
Ph: (503) 748-5799
Fax: (503) 748-8161
Toll Free: (800) 23-RUNCO (800-237-8626)

**PRODUCT INFORMATION
RETAIN FOR YOUR RECORDS**

Model Purchased _____ Date _____

Serial Number _____

Runco Authorized Dealer Name _____

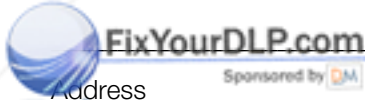

Discount-Merchant.com (800) 281-8860

City _____ State/Province _____ Postal Code _____

Phone _____ Fax _____

Important Safety Instructions

Thank you for your purchase of this quality Runco video product! It has been designed to provide you with the quality of video that is expected in a home theater. For the best performance, please read this manual carefully as it is your guide through the menus and operation.

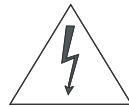
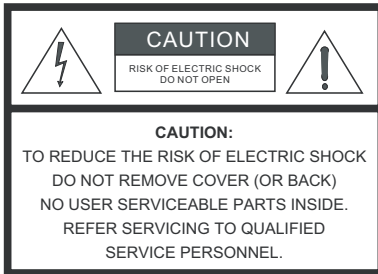

WARNING

This symbol is intended to alert the user to the presence of uninsulated "dangerous voltage" within the product's enclosure that may be of sufficient magnitude to constitute a risk of electric shock.



This symbol is intended to alert the user to the presence of important operating and maintenance (servicing) instructions in the literature accompanying the appliance.

1. Read these instructions.
2. Keep these instructions.
3. Heed all warnings.
4. Follow all instructions.
5. Do not use this apparatus near water.
6. Clean only with a dry cloth.
7. Do not block any of the ventilation openings. Install in accordance with the manufacturer's instructions.
8. Do not install near any heat sources such as radiators, heat registers, stoves, or other apparatus (including amplifiers) that produce heat.
9. Do not defeat the safety purpose of the polarized or grounding type plug. A polarized plug has two blades with one wider than the other. A grounding type plug has two blades and a third grounding prong. The wide blade or the third prong is provided for your safety. When the provided plug does not fit into your outlet, consult an electrician for the replacement of the obsolete outlet.
10. Protect the power cord from being walked on or pinched particularly at plugs, convenience receptacles and the point where they exit from the apparatus.
11. Only use the attachments/accessories specified by the manufacturer.
12. Use only with a cart, stand, tripod, bracket or table specified by the manufacturer or sold with the apparatus. When a cart is used, use caution when moving the cart/apparatus to avoid injury from tip-over.
13. Unplug this apparatus during lightning storms or when unused for long periods of time.
14. Refer all servicing to qualified service personnel. Servicing is required when the apparatus has been damaged in any way, such as power supply cord or plug is damaged, liquid has been spilled or objects have fallen into the apparatus, the apparatus has been exposed to rain or moisture, does not operate normally, or has been dropped.
15. The +12V trigger only outputs 12Vdc signal for triggering. Do not connect to any other power input or output. This could cause damage to this unit.
16. Keep the packing material in case the equipment should ever need to be shipped.
17. The lamp becomes extremely hot during operation. Allow the projector to cool down for approximately 45 minutes prior to removing the lamp assembly for replacement.
18. Do not operate lamps beyond the rated lamp life. Excessive operation of lamps beyond rated life could cause them to explode in rare occasions.



19. Never look directly into the lens when the lamp is on.

Compliance Information

DECLARATION OF CONFORMITY:

Manufacturer's Name: Runco International, LLC

Manufacturer's Address: 1195 NW Compton Drive, Beaverton, OR 97006-1992

hereby declares that the Products' Model Numbers:

VX-3000

conform with the provisions of:

Council Directive 2004/108/EC on Electromagnetic Compatibility;

EN 55022 "Limits and methods of measurements of radio interference characteristics of information technology equipment" 1998;

EN 55024 "Limits and methods of measurements of immunity characteristics of information technology equipment" 1998;

Including:

- EN 61000-4-2 "Electromagnetic compatibility (EMC) Part 4: Testing and measurement techniques Section 2: Electrostatic discharge immunity test"
- EN 61000-4-3 "Electromagnetic compatibility (EMC) Part 4: Testing and measurement techniques Section 3: Radiated, Radio-Frequency, Electromagnetic Field Immunity Test"
- EN 61000-4-4 "Electromagnetic compatibility (EMC) Part 4: Testing and measurement techniques Section 4: Electrical fast transient/burst immunity test"
- EN 61000-4-5 "Electromagnetic compatibility (EMC) Part 4: Testing and measurement techniques Section 5: Surge immunity test"
- EN 61000-4-6 "Electromagnetic compatibility (EMC) Part 4: Testing and measurement techniques Section 6: Conducted disturbances induced by radio-frequency fields immunity test"
- EN 61000-4-8 "Electromagnetic compatibility (EMC) Part 4: Testing and measurement techniques Section 8: Conducted disturbances induced by power frequency magnetic fields immunity test"
- EN 61000-4-11 "Electromagnetic compatibility (EMC) Part 4: Testing and measurement techniques Section 11: Voltage dips, short interruptions and voltage variations immunity tests"

And:

- EN 61000-3-2 "Electromagnetic compatibility (EMC) Part 3, Section 2: Limits for harmonic current emissions (equipment input current up to and including 16 A per phase)" 2000;
- EN 61000-3-3 "Electromagnetic compatibility (EMC) Part 3, Section 3: Limitations of voltage changes, voltage fluctuations and flicker in public low-voltage supply systems, for equipment with rated current up to and including 16 A and not subject to conditional connection" 1995;

Council Directive 2006/95/EC and amended by M1 and C1 on Low Voltage Equipment Safety;

EN 60950 "Safety of information technology equipment, including electrical business equipment"

The Technical Construction file required by this Directive is maintained at the corporate headquarters of Runco International, LLC, located at 1195 NW Compton Drive, Beaverton, OR 97006-1992.

Date of Declaration: September 2009

FCC PART 15:

NOTE: This equipment has been tested and found to comply with the limits for a Class B digital device, pursuant to Part 15 of the FCC Rules. These limits are designed to provide reasonable protection against harmful interference in a residential installation.

This equipment generates, uses and can radiate radio frequency energy and, if not installed and used in accordance with the instructions, may cause harmful interference to radio communications. However, there is no guarantee that interference will not occur in a particular installation. If this equipment does cause harmful interference to radio or television reception, which can be determined by turning the equipment off and on, the user is encouraged to try to correct the interference by one or more of the following measures:

- Reorient or relocate the receiving antenna.
- Increase the separation between the equipment and receiver.
- Connect the equipment into an outlet on a circuit different from that to which the receiver is connected.
- Consult the dealer or an experienced radio/TV technician for help.

INDUSTRY CANADA (ICES-003):

This Class B digital apparatus complies with Canadian ICES-003.

Cet appareil numérique de la classe B est conforme à la norme NMB-003 du Canada.

PRODUCT DISPOSAL:

The Product contains small amounts of tin, lead and/or mercury. Disposal of these materials may be regulated due to environmental considerations.

IMPORTANT RECYCLE INSTRUCTIONS



Lamp(s) inside this product contain mercury. This product may contain other electronic waste that can be hazardous if not disposed of properly. Recycle or dispose in accordance with local, state, or federal Laws.

For more information, contact the Electronic Industries Alliance at WWW.EIAE.ORG.

For lamp specific disposal information check WWW.LAMPRECYCLE.ORG.

DISPOSAL OF OLD ELECTRICAL AND ELECTRONIC EQUIPMENT (Applicable throughout the European Union and other European countries with separate collection programs)



This symbol found on your product or on its packaging, indicates that this product should not be treated as household waste when you wish to dispose of it. Instead, it should be handed over to an applicable collection point for the recycling of electrical and electronic equipment. By ensuring this product is disposed of correctly, you will help prevent potential negative consequences to the environment and human health, which could otherwise be caused by inappropriate disposal of this product. The recycling of materials will help to conserve natural resources. This symbol is only valid in the European Union. If you wish to discard this product, please contact your local authorities or dealer and ask for the correct method of disposal.

THE TRUSTED SOURCE FOR PROJECTOR LAMPS AND ACCESSORIES

Table of Contents

TWO YEAR LIMITED WARRANTY	iii
Important Safety Instructions.....	vi
Compliance Information	vii
1. Introduction	1
About This Manual	1
Target Audience	1
If You Have Comments About This Manual.....	1
Textual and Graphic Conventions	1
Using This Manual	2
Description, Features and Benefits	3
Key Features and Benefits	4
Parts List	4
2. Controls and Functions	5
VX-3000 at a Glance	5
VX-3000 Rear Panel	8
VX-3000 Remote Control	9
3. Installation	13
Remote Control	13
Notes on Batteries	13
Notes on Remote Control Operation.....	13
Quick Setup	14
Installation Considerations	15
Installation Type.....	15
Ambient Light	15
Throw Distance.....	16
Vertical and Horizontal Position.....	18
Vertical and Horizontal Lens Shift.....	18
Folded Optics	21
Other Considerations.....	21
Installing the Primary Projection Lens (VX-3000 Ultra only)	22
Installing the Optional CineWide/AutoScope Lens Mount	26
Installing the AutoScope Lens Motor.....	27
Installing the Fixed CineWide Base Plate (Prismatic Lens)	31



Discount-Merchant.com (800) 281-8860
 THE TRUSTED SOURCE FOR PROJECTOR LAMPS AND ACCESSORIES

Installing the Fixed CineWide Base Plate (Cylindrical Lens)	33
Mounting the VX-3000	36
Floor Mounting (Upright)	36
Ceiling Mounting (Inverted).....	36
Adjusting the Projector Height or Projection Angle	36
Connections to the VX-3000	36
Connector Panel Access.....	36
Connecting Source Components to the VX-3000	37
RS-232 Controller Connection	40
Connecting 12-Volt Trigger Output to External Theater Equipment	41
Connecting to AC Power	42
Turning on the Power	42
Primary Lens Adjustments	43
Focus and Zoom	43
Focus and Zoom – VX-3000 Ultra.....	43
Lens Shift	43
Changing the OSD Language	43
Adjusting the Picture Orientation	44
Installing and Adjusting the CineWide Anamorphic Lens	44
Cylindrical Anamorphic Lens Installation and Adjustment	45
Whitney (Prismatic) Anamorphic Lens Installation and Adjustment.....	50
4. Operation	53
Selecting Video Memory	53
Selecting an Aspect Ratio	53
Adjusting the Picture	53
Selecting An Input Source	53
Using Picture-In-Picture (PIP)	54
Using the On-Screen Menus	54
Main Menu.....	56
Source Select	56
Picture Adjust	56
Aspect Ratio	61
Installation.....	63
Information	67
Setup.....	67
ISF	69
5. Maintenance and Troubleshooting.....	73



Discount-Merchant.com (800) 281-8860
THE TRUSTED SOURCE FOR PROJECTOR LAMPS AND ACCESSORIES

Lamp Replacement	73
Troubleshooting Tips	74
6. Serial Communications	77
RS-232 Connection and Port Configuration	77
Serial Command Syntax	77
7. Specifications	87
VX-3000 Specifications	87
Overall Dimensions – VX-3000i/CineWide and VX-3000d/CineWide	90
Overall Dimensions – VX-3000 Ultra	91
Overall Dimensions – VX-3000i/CineWide with AutoScope and VX-3000d/CineWide with AutoScope	92
Supported Timings	93



Discount-Merchant.com (800) 281-8860
THE TRUSTED SOURCE FOR PROJECTOR LAMPS AND ACCESSORIES



Discount-Merchant.com (800) 281-8860
THE TRUSTED SOURCE FOR PROJECTOR LAMPS AND ACCESSORIES

List of Figures

2-1. VX-3000 Front/Side/Top View	5
2-2. VX-3000 Rear/Bottom/Side View	7
2-3. VX-3000 Rear Panel	8
2-4. VX-3000 Remote Control	9
3-1. Estimating Throw Distance	16
3-2. Projector Placement	18
3-3. Vertical Lens Shift (Example Only)	18
3-4. Horizontal Lens Shift (Example Only)	19
3-5. Folded Optics	21
3-6. VX-3000i/CineWide with AutoScope or VX-3000d/CineWide with AutoScope Motor Assembly – Exploded View	27
3-7. VX-3000 Ultra/CineWide with AutoScope Motor Assembly – Exploded View	28
3-8. VX-3000 with Ceiling Mount Adapters/Projector Stands	29
3-9. AutoScope Lens Motor Installation	30
3-10. Projector with Whitney (Prismatic) Lens Base Plate and Ceiling Mounting Plate - Bottom View	32
3-11. VX-3000i/CineWide or VX-3000d/CineWide with Rainier II/McKinley (Cylindrical) Lens Base Plate and Ceiling Mounting Plate - Exploded View	33
3-12. VX-3000 Ultra/CineWide with Rainier II/McKinley (Cylindrical) Lens Base Plate and Ceiling Mounting Plate - Exploded View	34
3-13. HDMI/DVI Source Connections	37
3-14. RGB Connections	38
3-15. Progressive Component Video Connections	38
3-16. Composite, S-Video and Component Video Connections	39
3-17. RS-232 Control System Connection	40
3-18. Connecting the 12-Volt Trigger Output to the AutoScope Lens Motor	41
3-19. Connecting the 12-Volt Trigger Output to Other Equipment	41
3-20. Cylindrical Anamorphic Lens Mounting Assembly - Exploded View	45
3-21. Attaching the Anamorphic Lens to the Lens Ring	46
3-22. Prismatic Anamorphic Lens Mounting Assembly - Exploded View	50
4-1. VX-3000 OSD Menu Structure	55
4-2. Typical PLUGE Pattern for Adjusting Brightness	57
4-3. Typical Gray Bar Pattern for Adjusting Contrast	58
4-4. Typical Color Bar Pattern for Adjusting Color Saturation and Tint	59
4-5. Typical Test Pattern for Adjusting Sharpness	60

4-6. Keystone Correction.....	64
4-7. Pincushion Correction	65
4-8. Gain and Offset	69
4-9. CIE 1931 Chromaticity Diagram	71
7-1. Overall Dimensions – VX-3000i/CineWide and VX-3000d/CineWide (Prismatic Lens) ..	90
7-2. Overall Dimensions – VX-3000 Ultra	91
7-3. Overall Dimensions – VX-3000i/CineWide with AutoScope	92



Discount-Merchant.com (800) 281-8860
THE TRUSTED SOURCE FOR PROJECTOR LAMPS AND ACCESSORIES

1. Introduction

This Owner's Manual describes how to install, set up and operate a Runco VX-3000 DLP™ Home Theater Projector.

Runco has prepared this manual to help home theater installers and end users get the most out of the VX-3000.

Runco has made every effort to ensure that this manual is accurate as of the date it was printed. However, because of ongoing product improvements and customer feedback, it may require updating from time to time. You can always find the latest version of this and other Runco product manuals on-line, at www.Runco.com.

Runco welcomes your comments about this manual. Send them to techpub@runco.com.

Text Conventions: The following conventions are used in this manual, in order to clarify the information and instructions provided:

- Remote and built-in keypad button identifiers are set in upper-case bold type; for example, "Press **EXIT** to return to the previous menu."
- Computer input (commands you type) and output (responses that appear on-screen) is shown in monospace (fixed-width) type; for example: "To select the Component 1 input, type X133X."
- All keys with functional names are initial-capped, set in bold type and enclosed in angle brackets. These keys are the following: **<Enter>**, **<Spacebar>**, **<Control>**, **<Esc>** and **<Tab>**.
- **<Enter>** indicates that you may press either the RETURN or ENTER key on your keyboard if it has both keys.

In addition to these conventions, underlining, boldface and/or italics are occasionally used to highlight important information, as in this example:



Note

*A carriage return **must** be used after each command or string.*

1.1 About This Manual

◀ *Target Audience*

◀ *If You Have Comments About This Manual...*

◀ *Textual and Graphic Conventions*



Discount-Merchant.com (800) 281-8860
THE TRUSTED SOURCE FOR PROJECTOR LAMPS AND ACCESSORIES

Graphic Conventions: These symbols appear in numerous places throughout the manual, to emphasize points that you must keep in mind to avoid problems with your equipment or injury:



Tip

TIPS highlight time-saving short cuts and helpful guidelines for using certain features.



Note

NOTES emphasize text with unusual importance or special significance. They also provide supplemental information.



Caution

CAUTIONS alert users that a given action or omitted action can degrade performance or cause a malfunction.



WARNING

WARNINGS appear when a given action or omitted action can result in damage to the equipment, or possible non-fatal injury to the user.



DANGER!

DANGER appears when a given action can cause severe injury or death.

1.2 Using This Manual

Use the following table to locate the specific information you need in this manual.

If you need...	... Turn to page:
Information about obtaining service	iv
General information about the VX-3000 Home Theater Projector	3
Installation instructions	13
First-time configuration instructions	43
Advanced configuration instructions	67
Troubleshooting tips	74
Specifications for the VX-3000 Home Theater Projector	87

The VX-3000 Home Theater Projector offer the astounding picture quality and versatility heretofore associated with more expensive projectors. Its 1920 x 1080, native-resolution DLP light engine features Runco's powerful SuperOnyx™ technology for bright, pristine high-definition (1080p) images.

Contrast ratio and dynamic range extend to new heights with Runco's exclusive Reflectance Volume Regulation™ (RVR), an electronically-controlled iris system.

This model features a precision optics package with electronic lens shift. The standard VX-3000 projection lens has a throw range of from 1.87 to 2.20 times the screen width.

The VX-3000's illumination system provides two light intensity levels to allow maximum flexibility for screen size, ambient light conditions, brightness and contrast balance, and lamp life preservation. It also has a newly refined cooling system, which increases efficiency and reduces noise levels.

The VX-3000 has been engineered to comply with Imaging Science Foundation™ (ISF) standards for maximum home theater image quality. Runco's sophisticated parameters for white balance and color gamut control have also been implemented for precise balance of gray scale and color. The VX-3000 incorporates Runco-proprietary de-interlacing technology that provides exceptional scaling and film-to-video (3:2 pulldown) conversion for the most artifact-free images possible.

For uncompromising widescreen reproduction of movies originally filmed in the “scope” (2.35:1) format, the VX-3000 can be equipped with Runco's patent-pending CineWide™ technology, a combination of software, electronics and high-quality anamorphic optics. CineWide maintains constant vertical height on the screen just as in a movie theater. When a viewer transitions from 1.78:1 (16:9) program material to 2.35:1, the image simply gets wider while full height is maintained. Also available with the VX-3000 is CineWide with AutoScope™, an enhanced, remote-controlled motorized version of CineWide.

**Note**

CineWide requires the use of a 2.35:1 or similar aspect ratio superwide format screen.

Discrete IR and RS-232 control make custom installation seamless, while discrete source and aspect ratio selection accommodate any automation control system.

1.3 Description, Features and Benefits



Discount-Merchant.com (800) 281-8860
THE TRUSTED SOURCE FOR PROJECTOR LAMPS AND ACCESSORIES

Key Features and Benefits ➤

The VX-3000 offers these key features and benefits:

- Native Resolution: 1920 x 1080 (16:9 Native Aspect Ratio)
- DLP system using SuperOnyx™ Digital Micromirror Device (DMD)
- 6-segment color wheel produces wide dynamic range and rich grayscale
- Picture in Picture function allows you to display two inputs on the screen at the same time
- Two (2) HDMI Inputs with High-bandwidth Digital Content Protection (HDCP)
- HDTV Compatible
- Reflectance Volume Regulation (RVR™) provides for infinitely variable adjustment of the light path through the optics, enabling the perfect balance of black and white levels for each individual installation

Parts List ➤

Your VX-3000 is shipped with the following items. If any items are missing or damaged, please contact your Runco dealer or Runco Customer Service at (800) 23-RUNCO.

- VX-3000 DLP Home Theater Projector
- Remote Control Unit and two (2), AAA-size batteries
- AC Power Cord, 8.2 feet (2.5 meters)
- Source Connection Cables, 9.8 feet (3.0 meters):
 - Component Video
 - HDMI to HDMI
- VX-3000 Installation/Operation Manual (this document)

Optional Accessories:

- Ceiling mount kit (part number 956-0099-00)
- CineWide™ technology (fixed, secondary anamorphic lens)
- CineWide™ with AutoScope™ system (secondary anamorphic lens and motorized mount)



Discount-Merchant.com (800) 281-8860
THE TRUSTED SOURCE FOR PROJECTOR LAMPS AND ACCESSORIES

2. Controls and Functions

Figure 2-1 and Figure 2-2 show the key VX-3000 components.

2.1 VX-3000 at a Glance

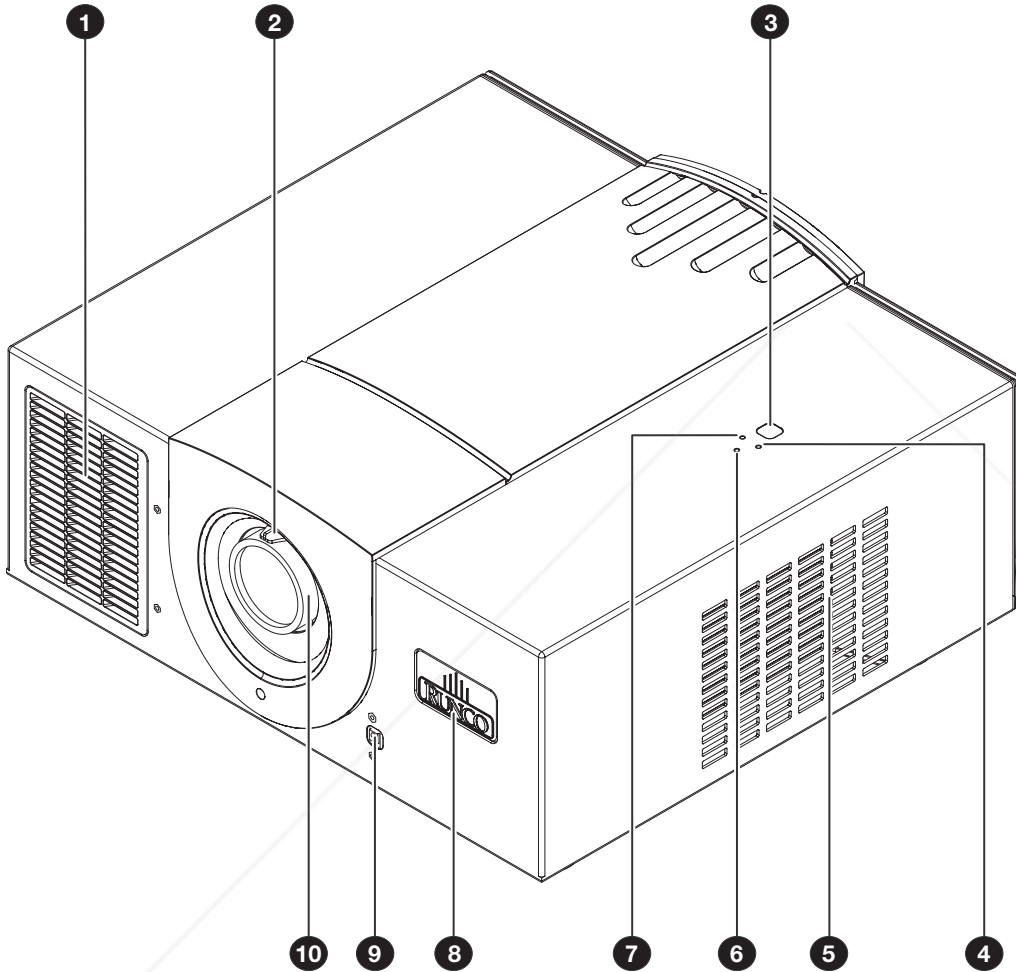

Figure 2-1. VX-3000 Front/Side/Top View

1. **EXHAUST VENT**

ZOOM TAB (Standard VX-3000)

Use this to change the projected image size with a standard VX-3000.

3. **TOP IR SENSOR**

Discount-Merchant.com (800) 281-8860
THE TRUSTED SOURCE FOR PROJECTOR LAMPS AND ACCESSORIES

4. **TEMP LED**

Indicates fan status and internal temperature as follows:

- Off during normal operation
- Red when internal temperature is too high or a fan failure occurs

5. **INTAKE VENT**

6. **POWER/STANDBY LED**

Indicates power status as follows:

- Orange when the projector is in standby mode
- Flashes green for approximately 45 seconds after the projector is turned on to indicate that the lamp is warming up
- Green during normal operation
- Flashes orange for approximately 110 seconds after the projector is turned off to indicate that the lamp is cooling down
- Red when an internal failure requiring service has occurred

7. **LAMP LED**

Indicates lamp status as follows:

- Off during normal operation
- Red when the lamp has exceeded its usage life or developed a problem

8. **RUNCO LOGO**

The logo can be rotated to match the projector orientation: inverted (ceiling-mounted) or upright. To rotate the logo, grip it at the sides, pull it away from the projector and rotate it 180 degrees.

9. **FRONT IR SENSOR**

10. **FOCUS RING (Standard VX-3000)**

To adjust the focus, grasp the lens by the outer ring and rotate it.



Discount-Merchant.com (800) 281-8860
THE TRUSTED SOURCE FOR PROJECTOR LAMPS AND ACCESSORIES

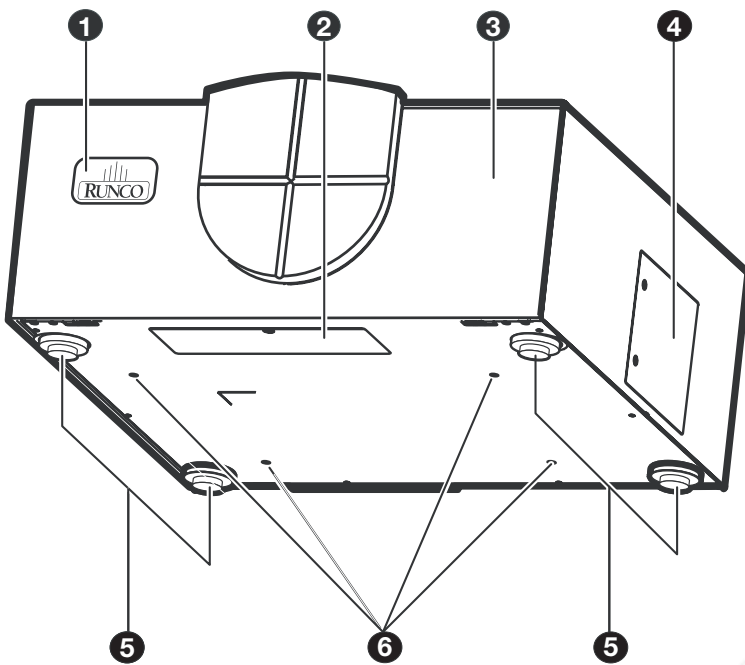

Figure 2-2. VX-3000 Rear/Bottom/Side View

1. **RUNCO LOGO**
The logo can be rotated to match the projector orientation: inverted (ceiling-mounted) or upright. To rotate the logo, grip it at the sides, pull it away from the projector and rotate it 180 degrees.
2. **CABLE OPENING**
Pass cables through this opening.
3. **CABLE ACCESS DOOR**
Open to access connectors.
4. **LAMP MODULE COVER**
Remove this cover to access the lamp compartment.
5. **FRONT/REAR ADJUSTERS**
Use these to adjust the projector height or projection angle.
6. **CEILING MOUNT HOLES**
Use these to attach the ceiling bracket to the projector.

2.2 VX-3000 Rear Panel

Figure 2-3 shows the VX-3000 rear panel.

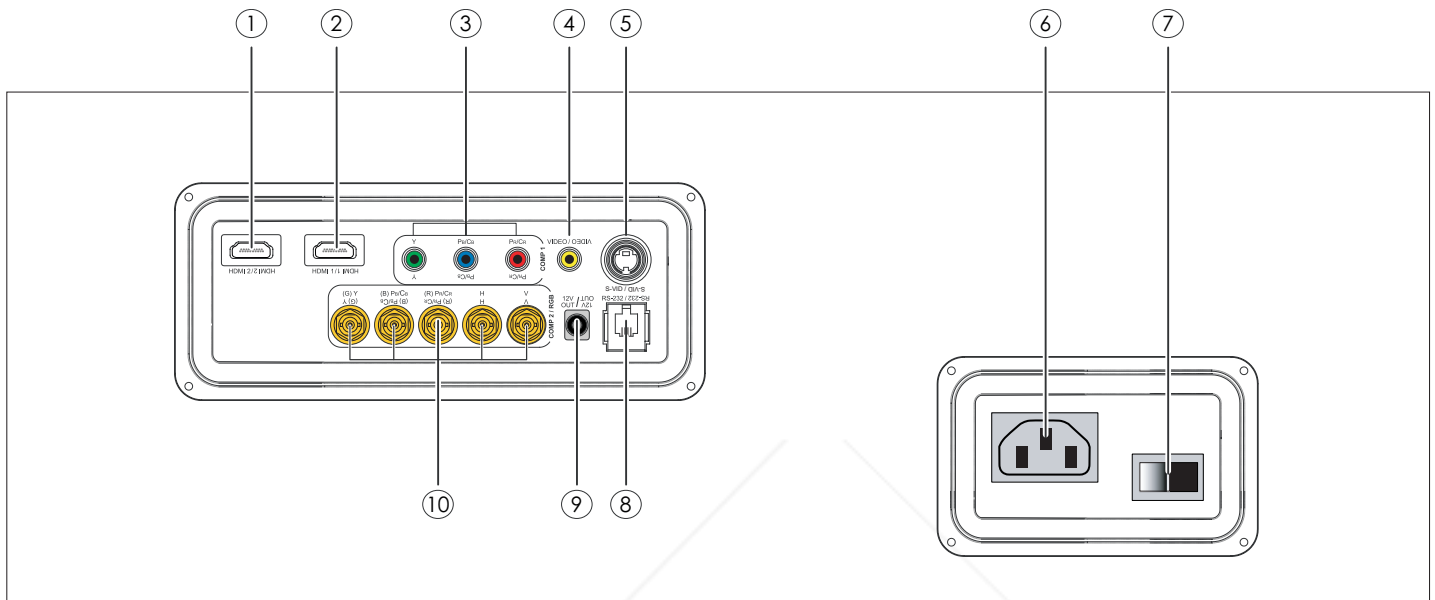

Figure 2-3. VX-3000 Rear Panel

1. **HDMI 1 (Digital)**
HDCP-compliant digital video input for connecting a DVD player or HD tuner with a DVI or HDMI output.
2. **HDMI 2 (Digital)**
3. **COMP 1 (RCA connectors)**
Standard- or high-definition (480i/480p/576i/576p/720p/1080i/1080p) Component (YPrPb) input for connecting a DVD/HD-DVD/BD player, HD set-top box or other SD/HD source.
4. **COMPOSITE VIDEO INPUT**
Standard composite video input for connecting a VCR, laser disc player or other composite video source.
5. **S-VIDEO**
A standard S-Video input for connecting a DVD player, satellite receiver or Super VHS (S-VHS) VCR.
6. **POWER INPUT (100 to 240 VAC)**
Connect the VX-3000 to power here.
7. **MAIN POWER SWITCH**
Disconnects or applies power to the VX-3000.
8. **RS-232 CONTROL PORT**
A female, RJ-11 connector for interfacing with a PC or home theater automation/control system.

9. **12-VOLT (250 mA) TRIGGER OUTPUT (3.5-mm, mini phono jack)**
 Connection for a 12-volt trigger-controlled device. This can be a retractable screen, screen mask or the Runco CineWide with AutoScope system.
10. **COMP 2 / RGB**
 Five BNCs for connecting either RGB or component (YPbPr), SD or HD video signals. (The VX-3000 automatically detects the signal format.)

Figure 2-4 shows the VX-3000 remote control, and the paragraphs that follow describe its functionality.

2.3 VX-3000 Remote Control

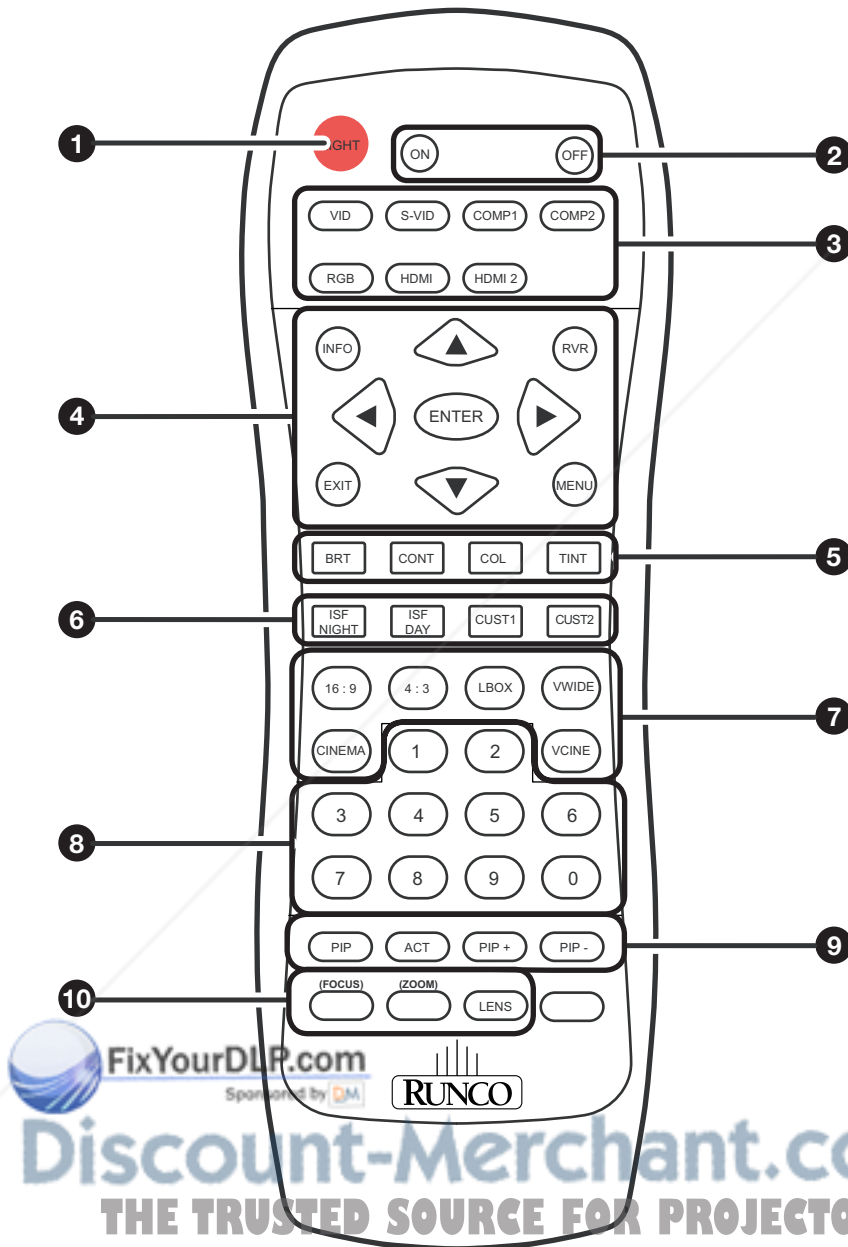

Figure 2-4. VX-3000 Remote Control

1. **LIGHT**

Press to illuminate the buttons.

2. **ON / OFF**

Use these buttons to turn the projector on or off.

3. **Source Selection Buttons:**

VID

Press to select Composite video input as the source.

S-VID (S-Video)

Press to select the S-Video input as the source.

COMP1

Press to select Component 1 video input as the source.

COMP2

Press to select Component 2 video input as the source.

RGB

Press to select the Component 2 RGB input.

HDMI / HDMI 2

Press to select an HDMI input.

4. **INFO**

Displays active source, signal resolution, aspect ratio and other projector status information.

Cursor Keys (▲, ◀, ▼, ▶)

Use these buttons to select items or settings, adjust settings or switch display patterns.

RVR (Reflectance Volume Regulation)

Adjusts the lens aperture (iris) setting according to the ambient light level in the viewing area.

EXIT

Press to save menu item setting(s), exit the current menu and return to the previous one.

ENTER

Press to select a highlighted menu item or confirm a changed setting.

MENU

Press this button to show or hide the on-screen display (OSD) controls.

5. Picture Adjustment Buttons:

BRT (Brightness)

Press to adjust black level.

CONT (Contrast)

Press to adjust white level.

COL (Color)

Press to adjust color intensity.

TINT

Press to adjust color hues.

6. Memory Preset Buttons:

ISF NIGHT

Press to recall settings for the current input from the "ISF Night" memory preset.

ISF DAY

Press to recall settings for the current input from the "ISF Day" memory preset.

CUST1 / CUST2

Press to recall settings for the current input from the "Custom 1" or "Custom 2" memory preset.

7. Aspect Ratio Selection Buttons

Use these buttons to select an aspect ratio directly, as follows:

16:9

For viewing 16:9 DVDs or HDTV programs in their native aspect ratio.

4:3

Scales the input signal to fit 4:3 display mode in the center of the screen.

LBOX (Letterbox)

For viewing LaserDisc movies or non-anamorphic DVDs on a 16:9 screen.

VWIDE (VirtualWide)

Enlarges a 4:3 image horizontally in a NON-linear fashion to fit 16:9 full screen display.

CINEMA

For viewing 2.35:1 source material.

VCINE (Virtual Cinema – CineWide-equipped projectors only)

Selects the Virtual Cinema aspect ratio, used for viewing 16:9 source material on a 2.35:1 screen.

8. 0 - 9

Use these keys to enter menu passcodes.

9. **Picture-In-Picture (PIP) Controls:**

ACT

Press to switch to the active window in PIP mode.

PIP

Press to activate PIP mode.

PIP+

Press to enlarge the PIP window.

PIP-

Press to shrink the size of the PIP window.

10. **Motorized Lens Controls:**

FOCUS (VX-3000 Ultra only)

Press to focus the image.

ZOOM (VX-3000 Ultra only)

Press to reduce or enlarge the projected image size.

LENS

Press to access the lens shift controls.



Discount-Merchant.com (800) 281-8860
THE TRUSTED SOURCE FOR PROJECTOR LAMPS AND ACCESSORIES

3. Installation

To install batteries in the remote control, push the battery cover and slide it off. Install the two AAA batteries with the correct polarity and then replace the cover.

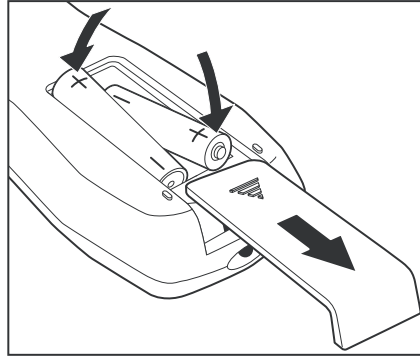

3.1 Remote Control

- Make sure that the battery polarities are correct when installing the batteries.
- Do not mix an old battery with a new one or different types of batteries.
- If you will not use the remote control for a long time, remove the batteries to avoid damage from battery leakage.
- Make sure that there is nothing obstructing the infrared beam between the remote control and the IR receiver on the projector.
- If the effective range of the remote control decreases, or it stops working, replace the batteries with new ones.
- The remote control may fail to operate if the infrared remote sensor is exposed to bright sunlight or fluorescent lighting.
- Ambient conditions may possibly impede the operation of the remote control. If this happens, point the remote control at the projector, and repeat the operation.

◀ Notes on Batteries

◀ Notes on Remote Control Operation

3.2 Quick Setup

Table 3-1 gives a quick overview of the VX-3000 installation process. The sections following this one provide detailed instructions.



Note

Installation should be performed by a qualified custom video installation specialist.

Table 3-1. Installation Overview

Step	Procedure	For Details, Refer to page...
1	Choose a location for the projector	15
2	Install primary projection lens (VX-3000 Ultra only)	22
3	If installing a CineWide-equipped projector: Install AutoScope lens motor or fixed CineWide base plate (optional)	26
4	Mount the projector	36
5	Connect signal sources to the VX-3000	37
6	Connect external controller to RS-232 port (optional)	40
7	Connect 12-volt trigger output to AutoScope lens motor or other equipment (optional)	41
8	Apply power to the projector	42
9	Primary lens adjustments: focus, projected image size (zoom) and position (shift)	18, 43
10	Change the OSD Language (optional)	43
11	For rear-screen and/or ceiling-mount installations, select the proper picture orientation	44
12	Install CineWide anamorphic lens (optional)	44
13	CineWide lens adjustments: position, pitch (angle), geometry and focus	47
14	Projector calibration: adjust the following for each input , save settings when finished: Aspect ratio Brightness Contrast Color level Tint Input position	61 through 66



Discount-Merchant.com (800) 281-8860
THE TRUSTED SOURCE FOR PROJECTOR LAMPS AND ACCESSORIES

Proper installation of your projector will ensure the quality of your display. Whether you are installing a projector temporarily or permanently, you should take the following into account to ensure your projector performs optimally.

Choose the installation type that best suits your needs: front or rear screen, floor mount or inverted mount. Table 3-2 compares these various installation methods.

Table 3-2. Projector Installation Options

Advantages	Considerations
Front Screen, Floor Mount Installation	
<ul style="list-style-type: none"> • Easy to set up • Can be moved or changed quickly • Easy to access 	<ul style="list-style-type: none"> • Shares floor space with audience
Front Screen, Inverted Mount (ceiling) Installation	
<ul style="list-style-type: none"> • Does not take up audience space • Projector is unobtrusive • Projector cannot be accidentally moved 	<ul style="list-style-type: none"> • Installation is more permanent • Projector access is more difficult
Rear Screen, Floor Mount Installation	
<ul style="list-style-type: none"> • Projector is completely hidden • Projector is easily accessed • Usually good ambient light rejection 	<ul style="list-style-type: none"> • Requires separate room • Installation cost is usually higher
Rear Screen, Inverted Mount (ceiling) Installation	
<ul style="list-style-type: none"> • Projector is completely hidden • Usually good ambient light rejection 	<ul style="list-style-type: none"> • Requires separate room • Installation cost is usually higher
Rear Screen, Floor Mount with Mirror	
<ul style="list-style-type: none"> • Projector is completely hidden • Usually good ambient light rejection • Requires less space behind screen than other rear screen installations 	<ul style="list-style-type: none"> • Requires separate room • Installation cost is usually higher

In general, minimize or eliminate light sources directed at the screen. Contrast ratio in your images will be noticeably reduced if light directly strikes the screen, such as when a shaft of light from a window or floodlight falls on the image. Images may then appear washed out and less vibrant.

3.3 Installation Considerations

◀ Installation Type

◀ Ambient Light



Discount-Merchant.com (800) 281-8860
THE TRUSTED SOURCE FOR PROJECTOR LAMPS AND ACCESSORIES

Throw Distance ➤ Throw distance is the distance measured from the front of the projector to the screen. This is an important calculation in any projector installation as it determines whether or not you have enough room to install your projector with a desired screen size and if your image will be the right size for your screen.

You can quickly estimate the throw distance by taking the width of the screen and multiplying it by the lens throw ratio; see Figure 3-1. The result of this calculation tells you roughly how far back the projector should be positioned from the screen in order to project a focused image large enough to fill the screen.

Estimating Throw Distance

Throw Distance (TD) = Screen Width (w) x Lens Throw Ratio

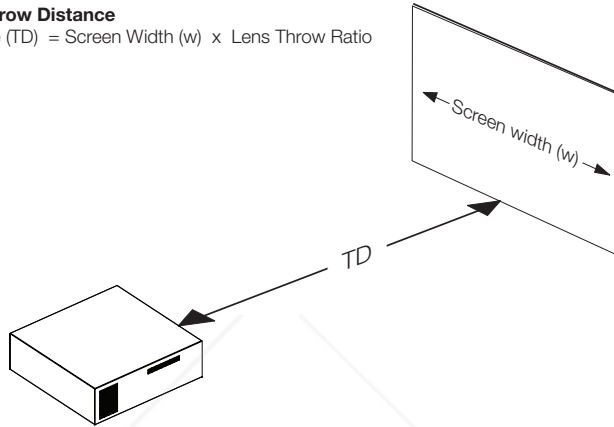

Figure 3-1. Estimating Throw Distance

Table 3-3 gives the throw ratios for the VX-3000.

Table 3-3. Throw Ratios for the VX-3000

Projector Model	Throw Ratio with Primary Lens Only	Throw Range in inches, with 72.6x40.8-inch (1.78:1) Screen		Throw Ratio with Primary Lens and Anamorphic Lens	Throw Range in inches, with 96x40.8-inch (2.35:1) Screen	
		Minimum	Maximum		Minimum	Maximum
Standard VX-3000	1.87 – 2.20	135.76	159.72		(n/a)	
VX-3000i/CineWide or VX-3000d/CineWide (Whitney Lens)		(n/a)		1.87 – 2.20	179.52	211.20
VX-3000i/CineWide or VX-3000d/CineWide (Rainier II Lens)		(n/a)		1.55 – 1.65	148.80	158.40
VX-3000i/CineWide with AutoScope or VX-3000d/CineWide with AutoScope (Rainier II Lens)	1.87 – 2.20	135.76	159.72	1.55 – 1.65	148.80	158.40



Discount-Measurement.com (800) 281-8860
 THE TRUSTED SOURCE FOR PROJECTOR LAMPS AND ACCESSORIES

Table 3-3. Throw Ratios for the VX-3000 (continued)

Projector Model	Throw Ratio with Primary Lens Only	Throw Range in inches, with 72.6x40.8-inch (1.78:1) Screen		Throw Ratio with Primary Lens and Anamorphic Lens	Throw Range in inches, with 96x40.8-inch (2.35:1) Screen	
		Minimum	Maximum		Minimum	Maximum
VX-3000i/CineWide or VX-3000d/CineWide (McKinley Lens)		(n/a)		1.40 – 1.65	134.40	158.40
VX-3000i/CineWide with AutoScope or VX-3000d/CineWide with AutoScope (McKinley Lens)	1.87 – 2.20	135.76	159.72	1.40 – 1.65	134.40	158.40



Discount-Merchant.com (800) 281-8860
THE TRUSTED SOURCE FOR PROJECTOR LAMPS AND ACCESSORIES

Vertical and Horizontal Position

Proper placement of the projector relative to the screen will yield a rectangular, perfectly-centered image that completely fills the screen.

Ideally, the projector should be positioned perpendicular to the screen and in such a way that the lens center is aligned with either the top or bottom edge of the screen area, and centered horizontally. See Figure 3-2.

Ceiling Installation

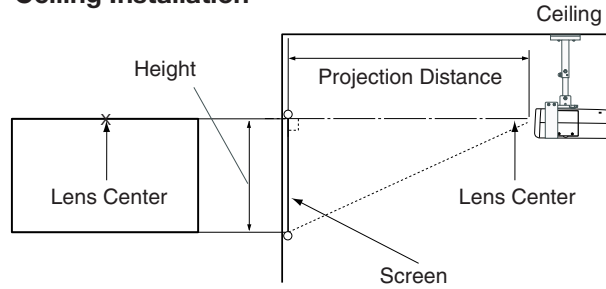

Floor Installation

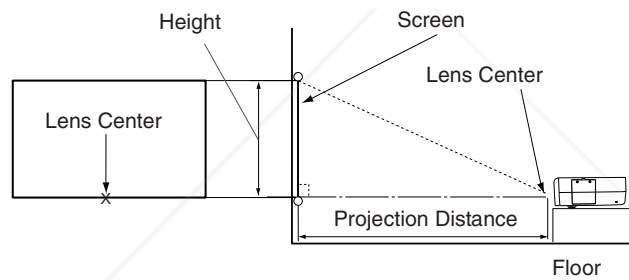
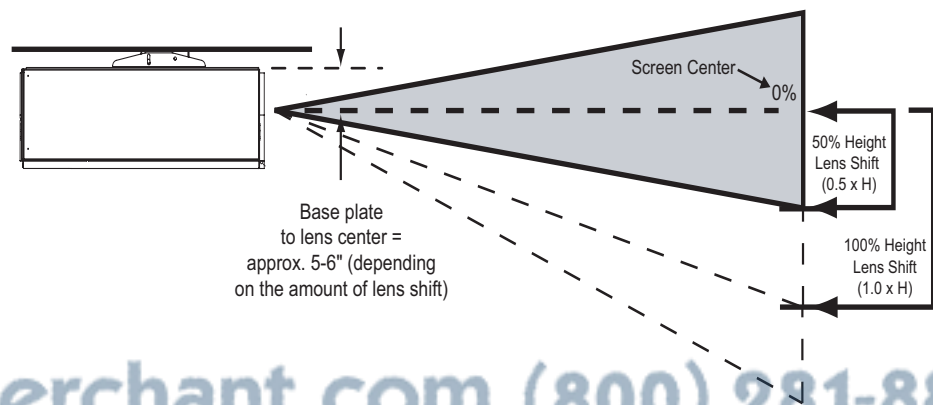

Figure 3-2. Projector Placement

Vertical and Horizontal Lens Shift

You can use the lens shift (LENS) controls on the projector remote to center the image on the screen. Lens shift is generally expressed as a percentage of the screen height or width, as shown in Figure 3-3 and Figure 3-4.



Note: This is a general example of lens shift. Lenses vary in their shift capabilities. **No particular lens or projector is used in this example.**

Figure 3-3. Vertical Lens Shift (Example Only)

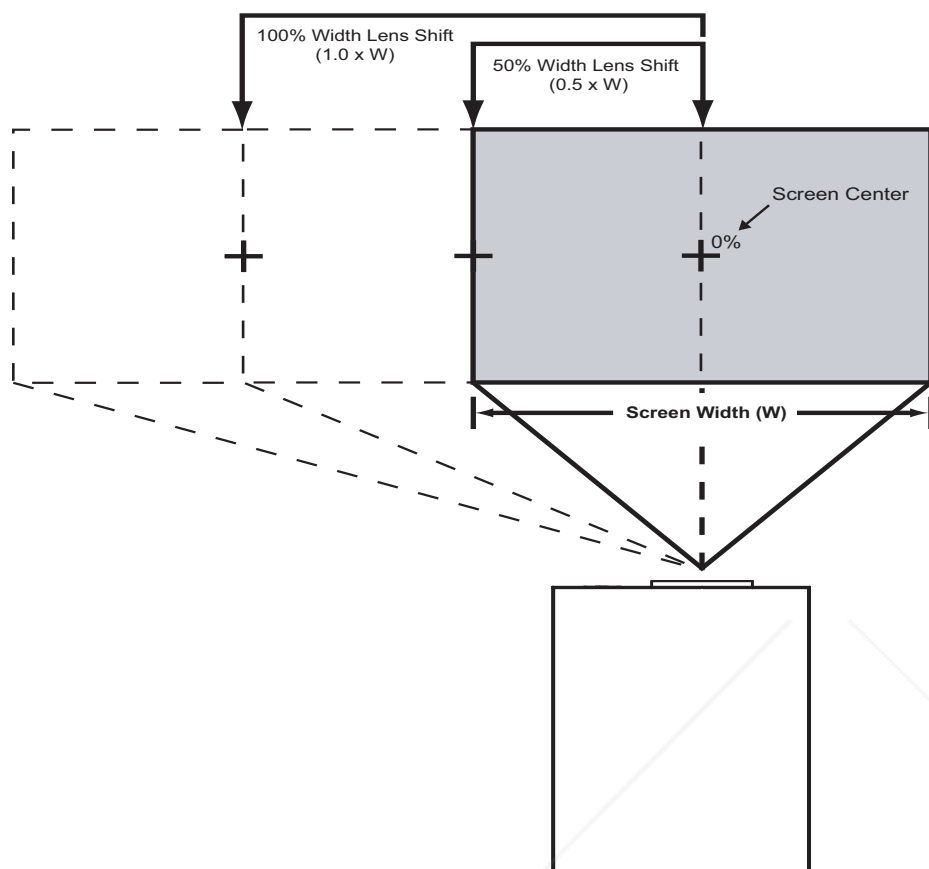

Note: This is a general example of lens shift. Lenses vary in their shift capabilities. **No particular lens or projector is used in this example.**

Figure 3-4. Horizontal Lens Shift (Example Only)



Discount-Merchant.com (800) 281-8860
THE TRUSTED SOURCE FOR PROJECTOR LAMPS AND ACCESSORIES

Table 3-4 lists the lens shift limits for each available VX-3000 lens, as percentages and absolute measurements with a 100 x 56 inch (1.78:1) screen.

Table 3-4. Vertical and Horizontal Lens Shift Limits

		Lens Option					
		VX-3000i/ VX-3000d	VX-3000 Ultra				
			Proteus B	Proteus C	Proteus D	Proteus E	Proteus F
Lens Shift Limits, as Percentages of Screen Height or Width (Notes 1, 2 and 3)							
Vertical (Notes 2 and 3)	Up	35%	18%	20%	20%	20%	20%
	Down	50%	25%	44%	44%	46%	46%
Horizontal (Note 2)	Left	0%	10% (Note 4)			10%	
	Right	0%	10% (Note 4)			10%	
Lens Shift Limits in Inches, with a 100-by-56 inch (1.78:1) Screen							
Vertical	Up	19.60	10.08	11.20	11.20	11.20	11.20
	Down	28.00	14.00	24.64	24.64	25.76	25.76
Horizontal	Left	0	10.00 (Note 4)			10.00	
	Right	0	10.00 (Note 4)			10.00	
Notes:							
1. With no vertical or horizontal lens shift, the lens center and screen center are aligned with each other.							
2. Vertical shift limits are percentages of the screen height. Horizontal shift limits are percentages of the screen width.							
3. Vertical lens shift figures are for ceiling mount configurations. For floor installations (where the projector is upright), reverse the up/down vertical lens shift percentages.							
4. With these lenses, horizontal lens shift is not possible when the maximum amount of vertical lens shift is used.							



Discount-Merchant.com (800) 281-8860
THE TRUSTED SOURCE FOR PROJECTOR LAMPS AND ACCESSORIES

In rear-screen applications where space behind the projector is limited, a mirror may be used to fold the optical path, as shown in Figure 3-5. The position of the projector and mirror must be accurately set. If you are considering this type of installation, contact your dealer for assistance.

◀ **Folded Optics**

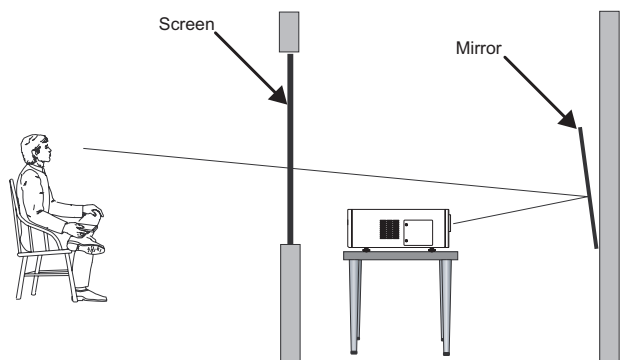

Figure 3-5. Folded Optics

Other considerations and tips that can help improve your installation:

◀ **Other Considerations**

- Keep the ambient temperature constant and below 35°C (95°F). Keep the projector away from heating and/or air conditioning vents. Changes in temperature may cause drifts in the projector circuitry, which may affect performance.
- Keep the projector away from devices that radiate electromagnetic energy such as motors and transformers. Common sources of these include slide projectors, speakers, power amplifiers and elevators.



Discount-Merchant.com (800) 281-8860
THE TRUSTED SOURCE FOR PROJECTOR LAMPS AND ACCESSORIES

3.4 Installing the Primary Projection Lens (VX-3000 Ultra only)

The VX-3000 Ultra primary projection lens is shipped separately from the projector. Proceed as follows to install it:

1. Carefully remove the projector from the shipping container and place it on a flat surface.



2. Loosen the Phillips screw at the bottom of the decorative bezel on the front of the projector.



3. Grasp the bezel by the front, then rotate and lift it upward to remove it. (Don't pull it straight out.)

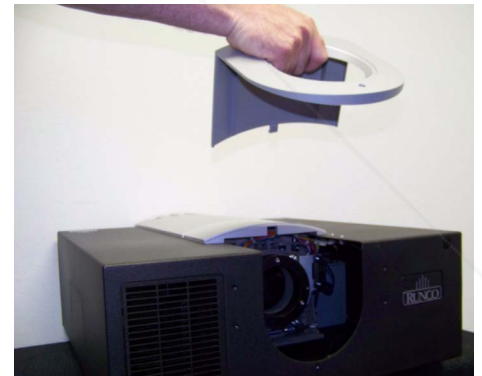

4. Carefully remove the lens from the shipping container.

- Remove the rear cap from the lens. This protective cap is only used during shipping to protect the lens from damage.



- Carefully** cut and remove the plastic band around the lens motor connector wires. **Take great care not to cut the wires!**



- Detach the lens motor connector from the motor by removing the two screws holding it in place.

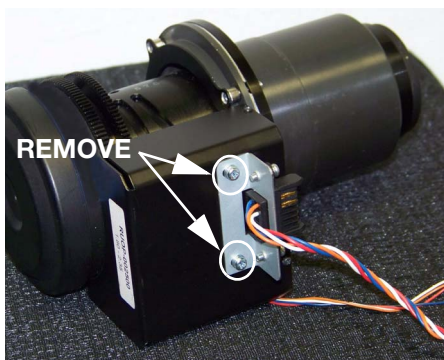

- Note that the lens mount flange has a female socket connector for the lens motor on the right side of the flange.

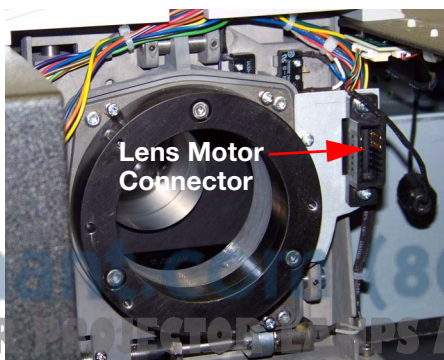

Discount-Merch (800) 281-8860
 THE TRUSTED SOURCE FOR STILLS AND ACCESSORIES

Note that the lens assembly motor has a male socket connector.

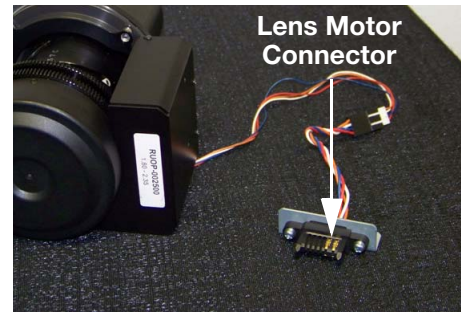

9. Remove the front cap from the lens.



10. Connect the lens motor to the projector.



11. Hold the lens assembly with the motor facing upward. **Carefully** insert the back of the lens assembly into the hole in the lens flange.

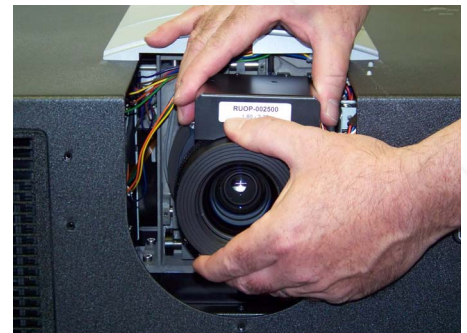

12. Gently push the lens assembly in until it is seated flush against the flange and the guide pin on the lens assembly is fully seated in the hole on the flange.

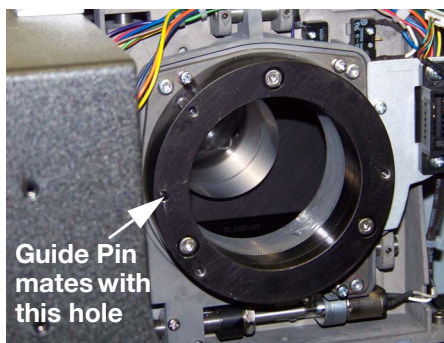
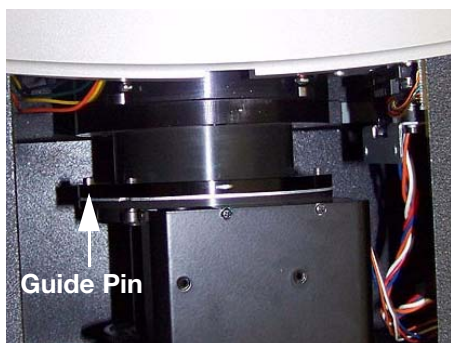

13. Secure the lens assembly to the projector flange with the three Allen screws on the outer ring of the assembly, using a 3-mm hex driver.

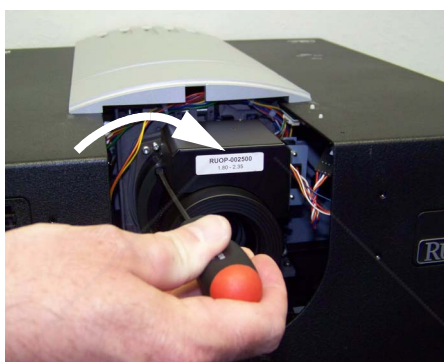

Caution

Tighten **only** these three screws. Do not attempt to adjust any of the screws behind the lens flange. Doing so may cause the lens to malfunction.

14. Install the foam shield around the front of the lens.



Replace the front lens bezel.

16. Tighten the Phillips screw on the bottom of the bezel to secure it.

FixYourDLP.com
Sponsored by DM

Discount-Merchant.com (800) 281-8860
THE TRUSTED SOURCE FOR PROJECTOR LAMPS AND ACCESSORIES

3.5 Installing the Optional CineWide/AutoScope Lens Mount

If you are installing a standard (non-CineWide) VX-3000i, VX-3000d or VX-3000 Ultra, skip this step and proceed with **Mounting the VX-3000** (page 36).

If you are installing a CineWide projector equipped with a **prismatic** (Whitney) anamorphic lens, proceed with **Installing the Fixed CineWide Base Plate (Prismatic Lens)** (page 31).

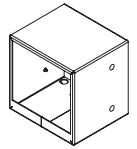

If you are installing a CineWide projector equipped with a **cylindrical** (Rainier II or McKinley) anamorphic lens, proceed with **Installing the Fixed CineWide Base Plate (Cylindrical Lens)** (page 33).

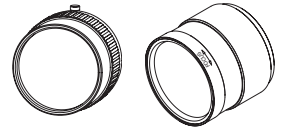

If you are installing a VX-3000i/CineWide with AutoScope, VX-3000d/CineWide with AutoScope or VX-3000 Ultra/CineWide with AutoScope, proceed as follows to install the AutoScope lens motor.



Note

1. Do not install the CineWide lens yet, only the fixed CineWide base plate or AutoScope lens motor. You will install the CineWide lens after you install the projector and adjust the primary lens.
2. Some components shipped with your projector may differ slightly from what is shown in these instructions.

Figure 3-6 shows the VX-3000i/CineWide with AutoScope or VX-3000d/CineWide with AutoScope motor assembly.

◀ **Installing the AutoScope Lens Motor**

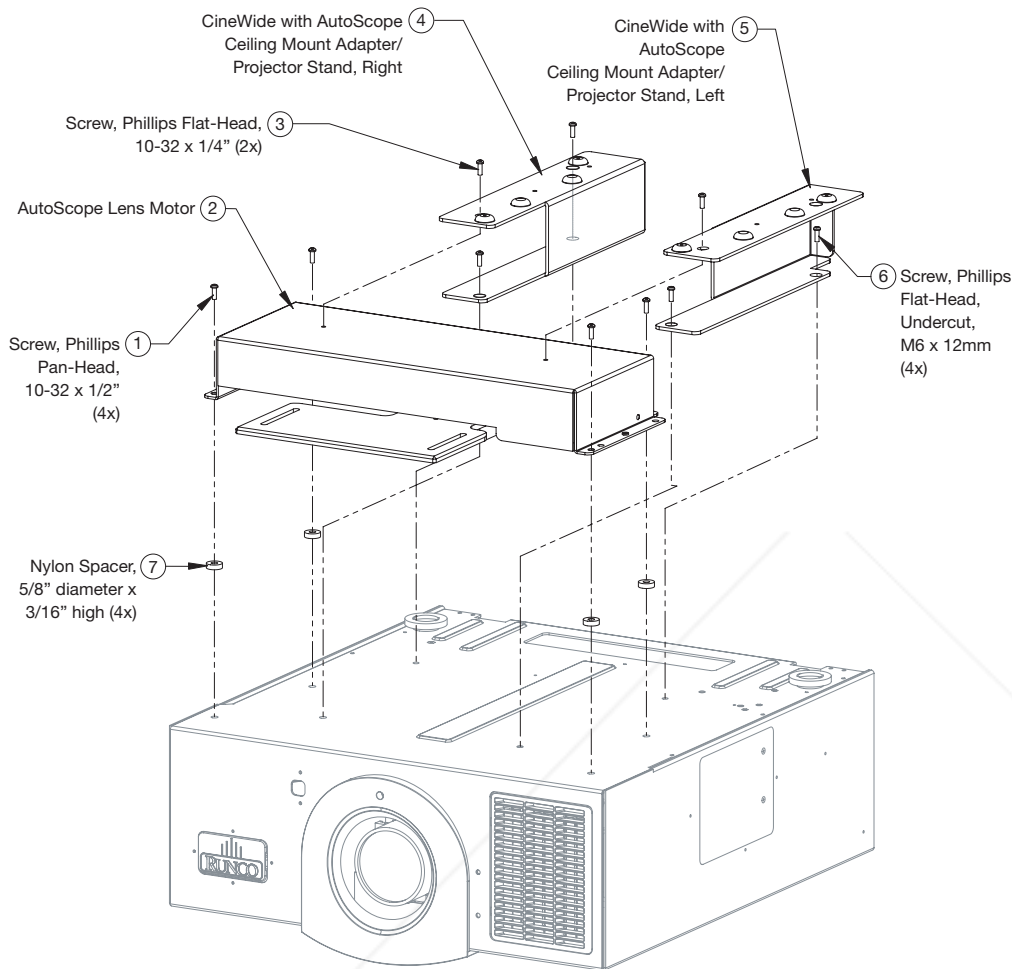

Figure 3-6. VX-3000i/CineWide with AutoScope or VX-3000d/CineWide with AutoScope Motor Assembly – Exploded View



Discount-Merchant.com (800) 281-8860
THE TRUSTED SOURCE FOR PROJECTOR LAMPS AND ACCESSORIES

Figure 3-7 shows the VX-3000 Ultra/CineWide with AutoScope motor assembly.

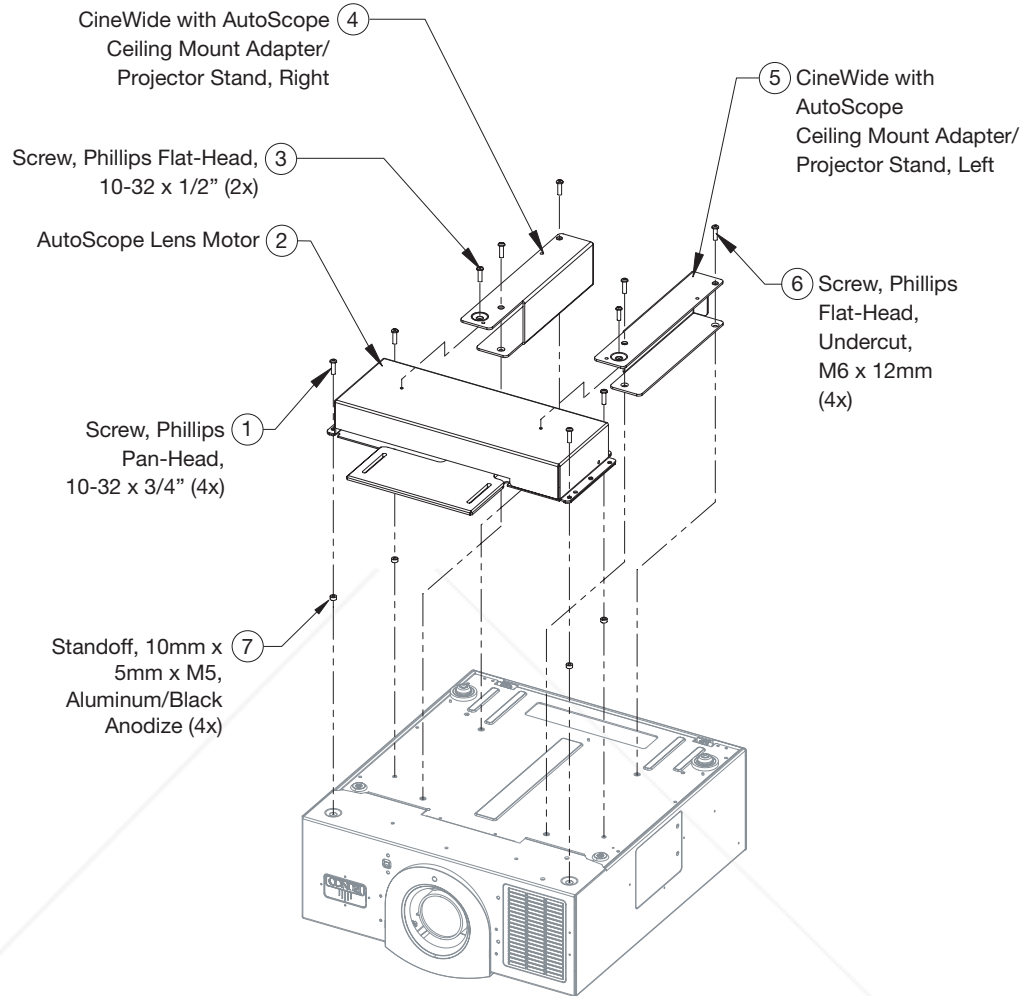
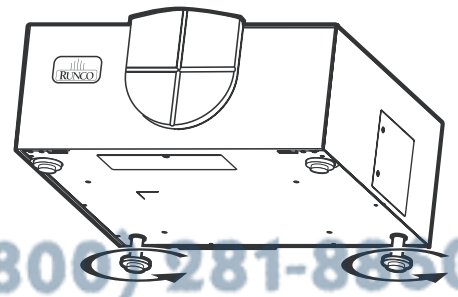

Figure 3-7. VX-3000 Ultra/CineWide with AutoScope Motor Assembly – Exploded View

Remove Projector Front Height Adjusters:

Place the projector upside down on a blanket or other soft surface. Then, remove the two height adjusters at the front of the projector by turning them counterclockwise until they come out.



Install Ceiling Mount Adapters/Projector Stands: For ceiling installations, these brackets bring the mounting points for the projector mounting plate (included with the projector ceiling mount kit) from the bottom of the projector up and around the AutoScope lens motor housing. For floor installations (where the projector is upright), the adapters allow the projector to lie flat on the mounting surface.

Using the four (4), supplied M6 x 12mm Flat-Head Phillips screws (item #6), attach the AutoScope Ceiling Mount Adapters/Projector Stands (items #4 and #5) to the projector as shown in Figure 3-8.

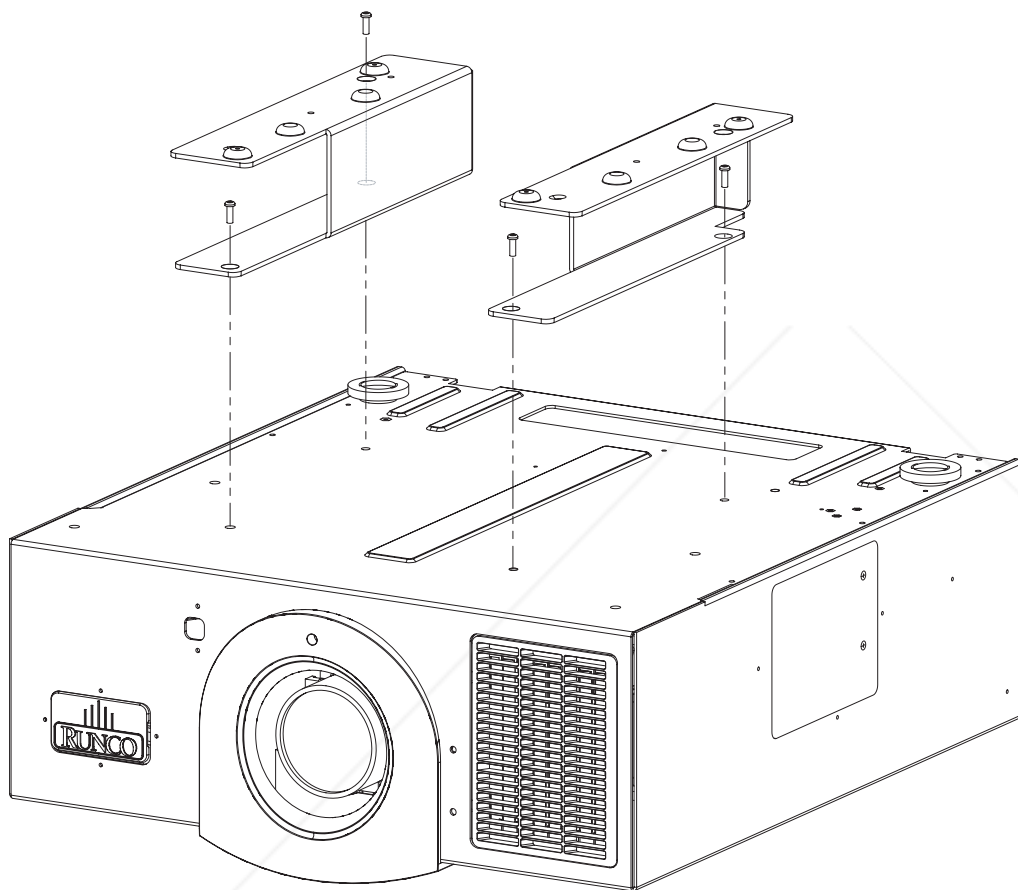

Figure 3-8. VX-3000 with Ceiling Mount Adapters/Projector Stands

DO NOT OVER-TIGHTEN THE SCREWS.



Discount-Merchant.com (800) 281-8860
THE TRUSTED SOURCE FOR PROJECTOR LAMPS AND ACCESSORIES

Install Lens Motor:

1. Position the AutoScope Lens Motor (item #2) as shown in Figure 3-9.
2. Line up the mounting holes on the lens motor housing with those on the underside of the projector.
3. Secure the motor to the projector with the four (4), supplied 10-32 Pan-Head Phillips screws (item #1) and nylon spacers or aluminum standoffs (item #7).
4. Secure the AutoScope Ceiling Mount Adapters/Projector Stands to the motor using the two (2), supplied 10-32 Flat-Head Phillips screws (item #3).

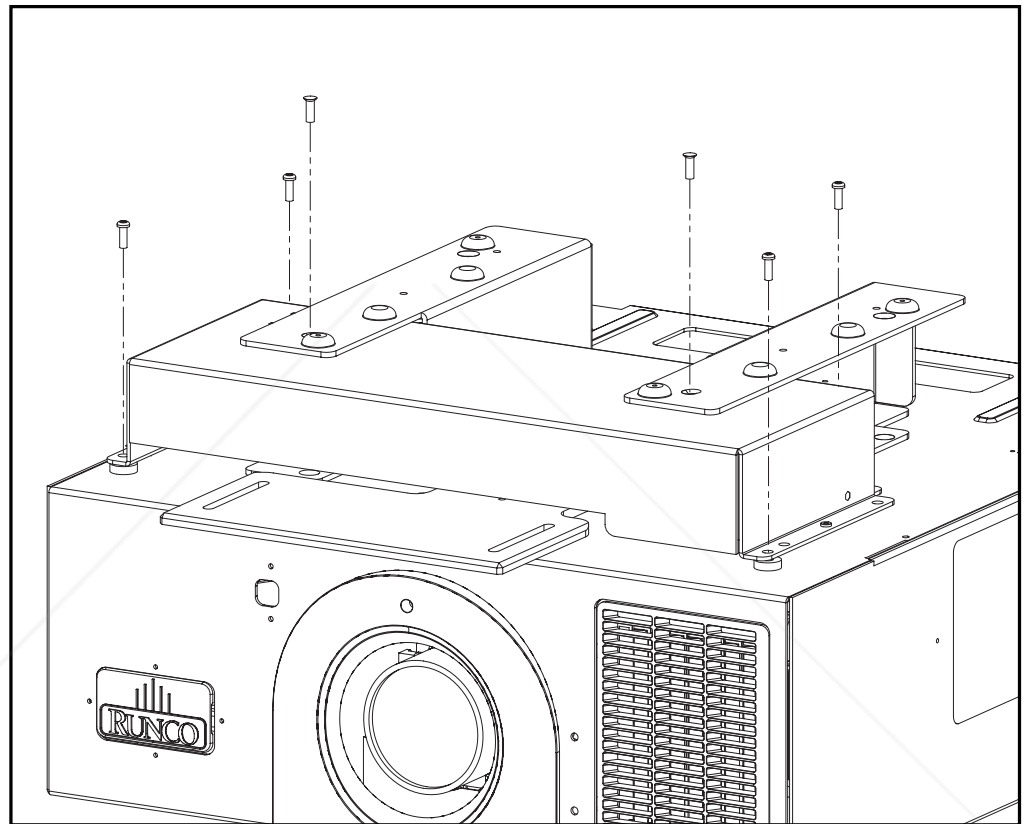

Figure 3-9. AutoScope Lens Motor Installation

After you have installed the AutoScope lens motor, proceed with **Mounting the VX-3000** on page 36.

To install the fixed CineWide base plate on a VX-3000i/CineWide, VX-3000d/CineWide or VX-3000 Ultra/CineWide with a **prismatic** anamorphic lens:

1. Place the projector upside down on a blanket or other soft surface.
2. **For a standard VX-3000i/CineWide or VX-3000d/CineWide that is to be ceiling-mounted:** Line up the four holes on the projector ceiling mounting plate (included with the projector ceiling mount kit) with those on the bottom of the projector.
3. Line up the two mounting holes on the CineWide base plate with those on the bottom of the projector (and at the front of the ceiling mount plate, if present).
4. Secure the CineWide base plate (and ceiling mounting plate, if needed) to the projector with the M6x12mm screws and washers provided with the CineWide lens base plate. See Figure 3-10.

◀ **Installing the Fixed CineWide Base Plate (Prismatic Lens)**



Caution

1. Do not use the mounting screws provided with the ceiling mounting plate. Use only the hardware provided with the CineWide lens base plate.
2. DO NOT OVER-TIGHTEN THE SCREWS.
3. Washers are not needed to install the base plate on a VX-3000 Ultra.



Discount-Merchant.com (800) 281-8860
THE TRUSTED SOURCE FOR PROJECTOR LAMPS AND ACCESSORIES

**VX-3000i/CineWide or
VX-3000d/CineWide with Prismatic Lens
Base Plate**

**VX-3000i/CineWide or
VX-3000d/CineWide with Prismatic Lens
Base Plate and Ceiling Mounting Plate**

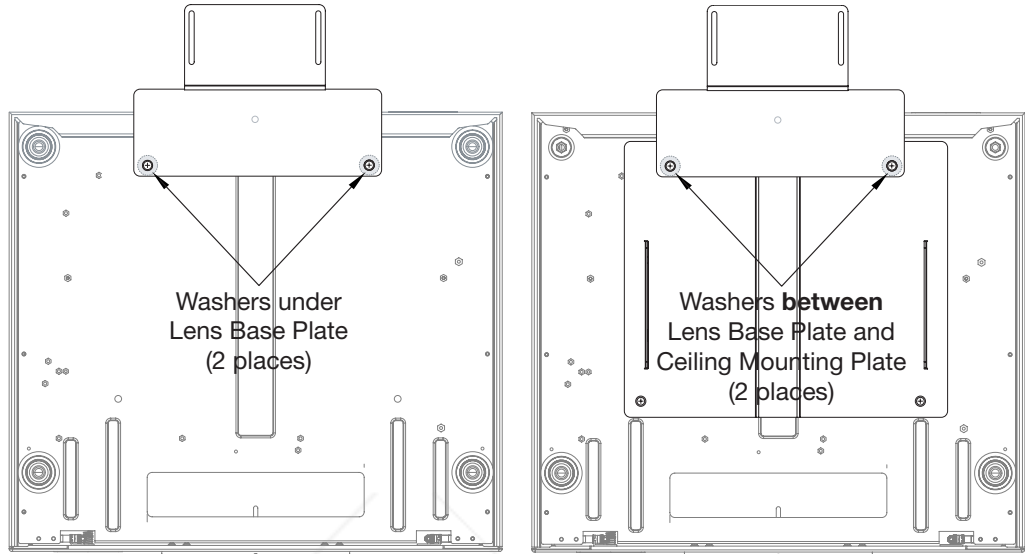

**VX-3000 Ultra/CineWide
with Prismatic Lens Base Plate**

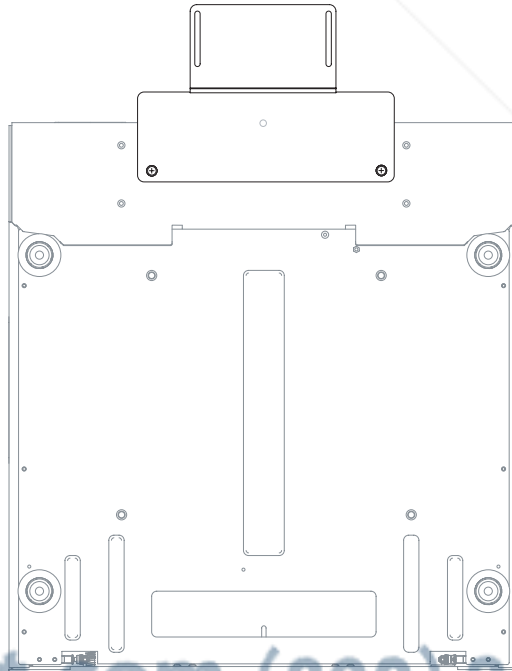

Figure 3-11 shows the cylindrical (Rainier II/McKinley) lens base plate assembly for a VX-3000i/CineWide or VX-3000d/CineWide.

◀ **Installing the Fixed CineWide Base Plate (Cylindrical Lens)**

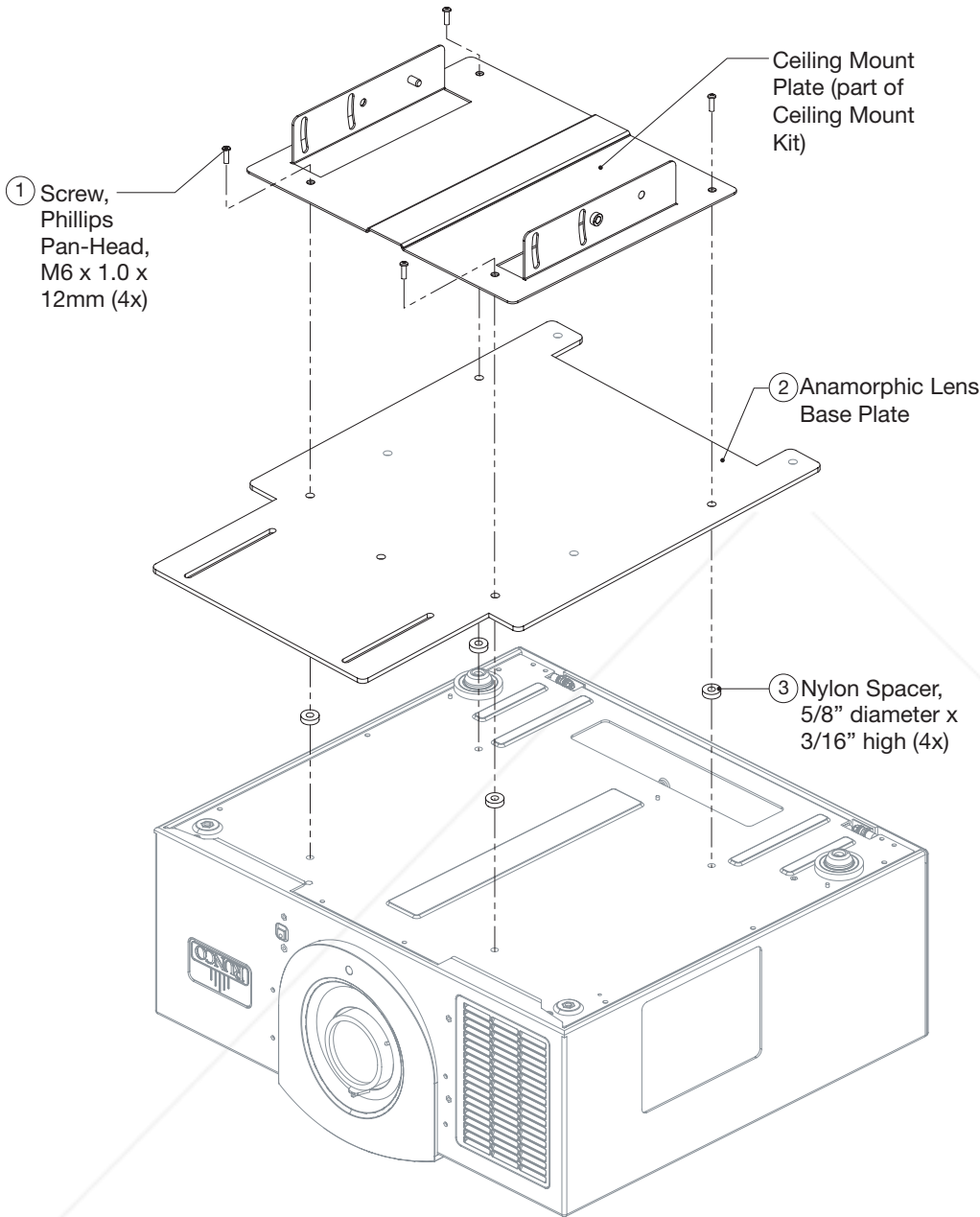

Figure 3-11. VX-3000i/CineWide or VX-3000d/CineWide with Rainier II/McKinley (Cylindrical) Lens Base Plate and Ceiling Mounting Plate - Exploded View

Discount-Merchant.com (800) 281-8860
 THE TRUSTED SOURCE FOR PROJECTOR LAMPS AND ACCESSORIES

Figure 3-12 shows the VX-3000 Ultra/CineWide cylindrical (Rainier II/McKinley) lens base plate assembly.

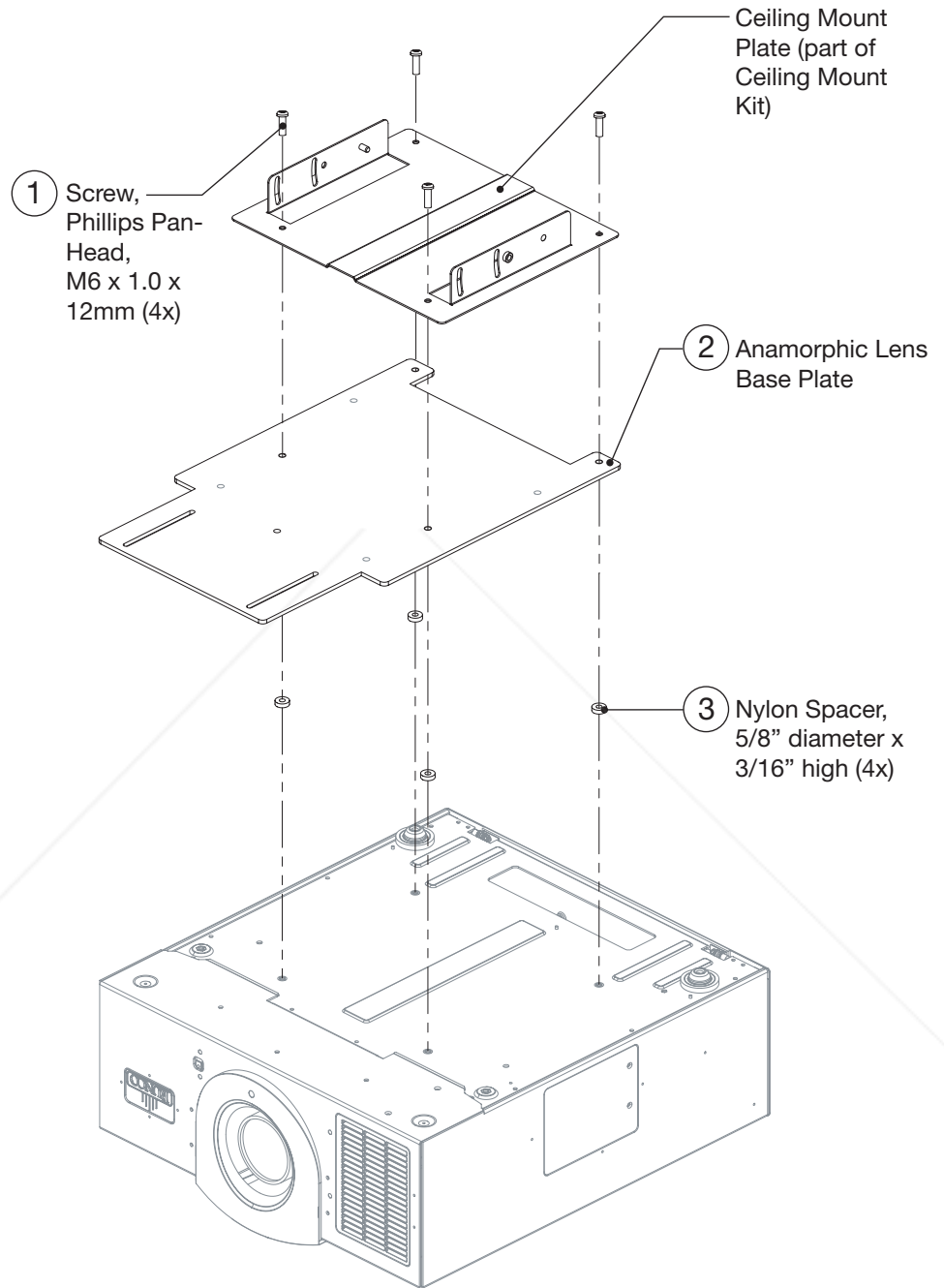

Figure 3-12. VX-3000 Ultra/CineWide with Rainier II/McKinley (Cylindrical) Lens Base Plate and Ceiling Mounting Plate - Exploded View

1. Place the projector upside down on a blanket or other soft surface.
2. Install a nylon spacer (item #3) at each mounting hole location.
3. Place the CineWide base plate (item #2) on the bottom of the projector. For a standard VX-3000i/CineWide or VX-3000d/CineWide, position the plate as shown in Figure 3-11; for a VX-3000 Ultra/CineWide, position the plate as shown in Figure 3-12.
4. **If you are mounting the projector on a ceiling:** Line up the four holes on the projector ceiling mounting plate (included with the projector ceiling mount kit) with those on the bottom of the projector and CineWide base plate.
5. Secure the CineWide base plate (and ceiling mounting plate, if needed) to the projector with the M6x12mm screws (item #1) and nylon spacers provided with the CineWide lens base plate.

**Caution**

1. **Do not use the mounting screws provided with the ceiling mounting plate.** Use only the hardware provided with the CineWide lens base plate.
2. **DO NOT OVER-TIGHTEN THE SCREWS.**



Discount-Merchant.com (800) 281-8860
THE TRUSTED SOURCE FOR PROJECTOR LAMPS AND ACCESSORIES

3.6 Mounting the VX-3000

There are several methods for mounting the projector. Depending on your chosen installation, one method may be more suitable than another.

Floor Mounting (Upright) ➤

In typical front and rear screen installations, the projector can be mounted to a secure and level surface such as a table or cart. Carts are useful when moving a projector during a presentation or from site to site. If possible, lock the wheels when it's in position to prevent it from being moved during a presentation.

Ceiling Mounting (Inverted) ➤

For fixed installations, and for those that want the projector out of sight or have a limited space for projector and audience, you can invert the VX-3000 and suspend it from the ceiling using a specially-designed ceiling mount fixture.



Note

Use only the Runco-approved ceiling mount kit designed for your projector. Install the mount kit according to the instructions provided with it.

The projector can also be inverted and placed in an enclosure above and behind the viewing area. Install four feet on the inside bottom surface of the enclosure on which the projector can rest. A variety of materials can be used for this purpose (for example, rubber crutch tips or turntable feet).

Adjusting the Projector Height or Projection Angle ➤

If the screen is significantly higher or lower than the projector, you can also tilt the projector at a slight angle. In a ceiling installation, you do this by adjusting the ceiling mount.

For a floor installation, turn the four adjustable feet on the bottom of the projector to adjust the projector height and/or projection angle.

If you do this, you may need to make keystone adjustments or vertically shift the image using the on-screen display (OSD) controls, to compensate. For detailed instructions, refer to **Using the On-Screen Menus** on page 54.

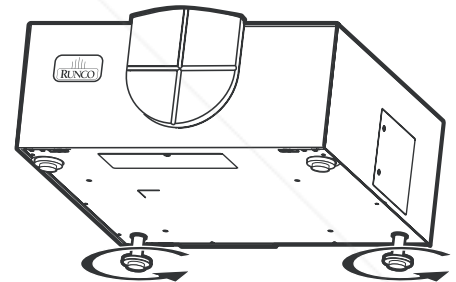

3.7 Connections to the VX-3000

Proceed as follows to connect the VX-3000 to your video sources, external controller(s) – if present – and AC power.

When connecting your equipment:

- Turn off all equipment before making any connections.
- Use the correct signal cables for each source.
- Ensure that the cables are securely connected. Tighten the thumbscrews on connectors that have them.



Connector Panel Access

To access the connector panel, pull firmly on the cable access cover to open it.

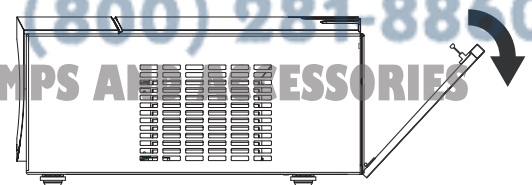

Discount-Merchant.com (800) 281-8860
THE TRUSTED SOURCE FOR PROJECTOR LAMPS AND ACCESSORIES

Connect your video sources to the VX-3000 as shown and described in the sections that follow.

◀ **Connecting Source Components to the VX-3000**

HDMI/DVI Connections: See Figure 3-13. With an HDMI source, use the included HDMI-to-HDMI cable; with a DVI source, use a DVI-to-HDMI cable.



Tip

Use the HDMI input whenever possible. This ensures the highest video quality because the signal is carried in the digital domain throughout the entire signal path, from source component output into the projector.

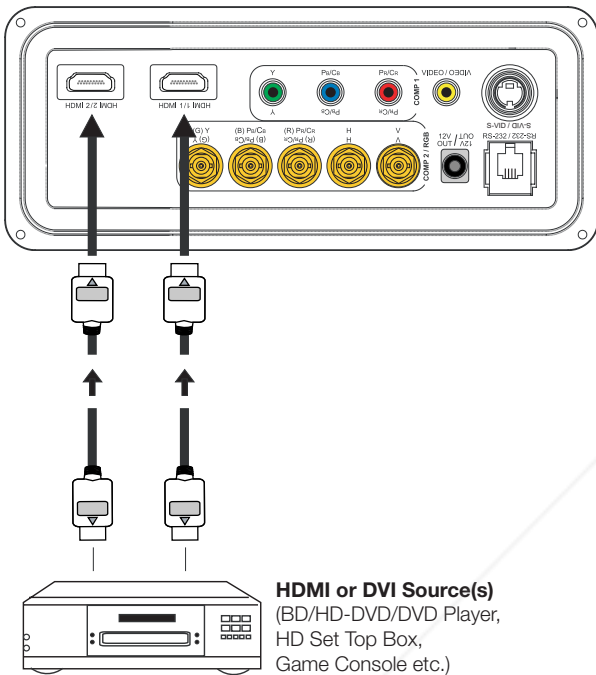

Figure 3-13. HDMI/DVI Source Connections



Discount-Merchant.com (800) 281-8860
THE TRUSTED SOURCE FOR PROJECTOR LAMPS AND ACCESSORIES

RGB Connections: Connect your personal computer or other RGB source (DVD player or HD set top box) to the **COMP 2/RGB** input; see Figure 3-14. You can use a DB15HD-to-5 x BNC cable if your RGB source has a 15-pin, VGA-type connector.

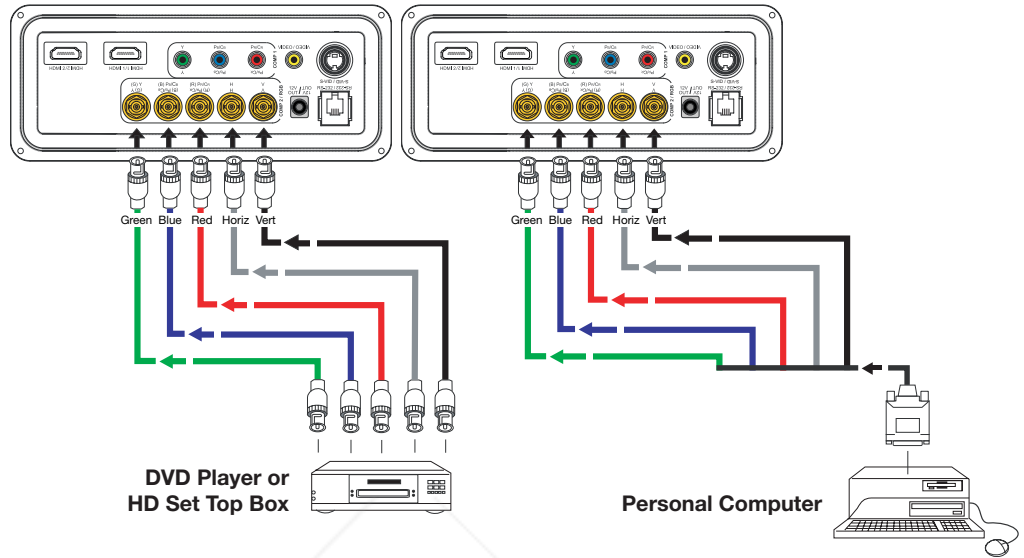

Figure 3-14. RGB Connections

Progressive Component Video Connections: Connect your progressive component source (DVD player or HD set top box) to the **COMP 2/RGB** input as shown in Figure 3-15.

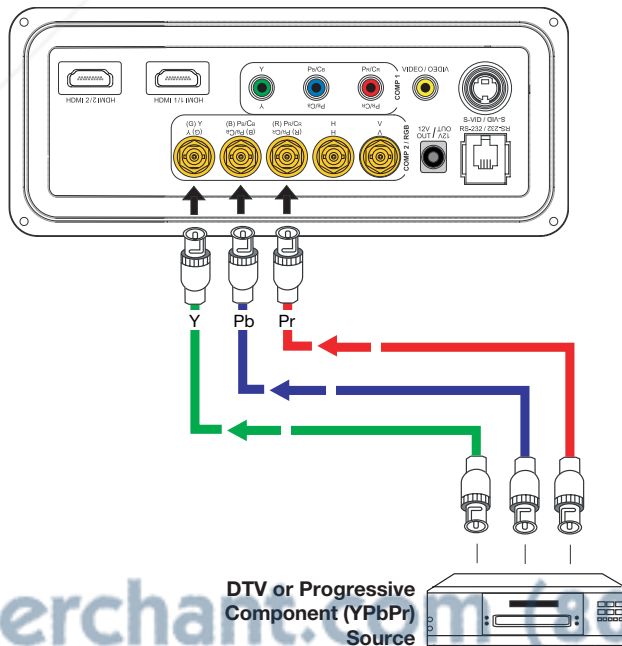

Figure 3-15. Progressive Component Video Connections



Discount-Merchants.com (800) 281-8860

THE TRUSTED SOURCE FOR PROJECTOR LAMPS AND ACCESSORIES

Composite/S-Video/Component Video Connections: Connect your composite, S-Video and component video sources to the VX-3000 as shown in Figure 3-16.

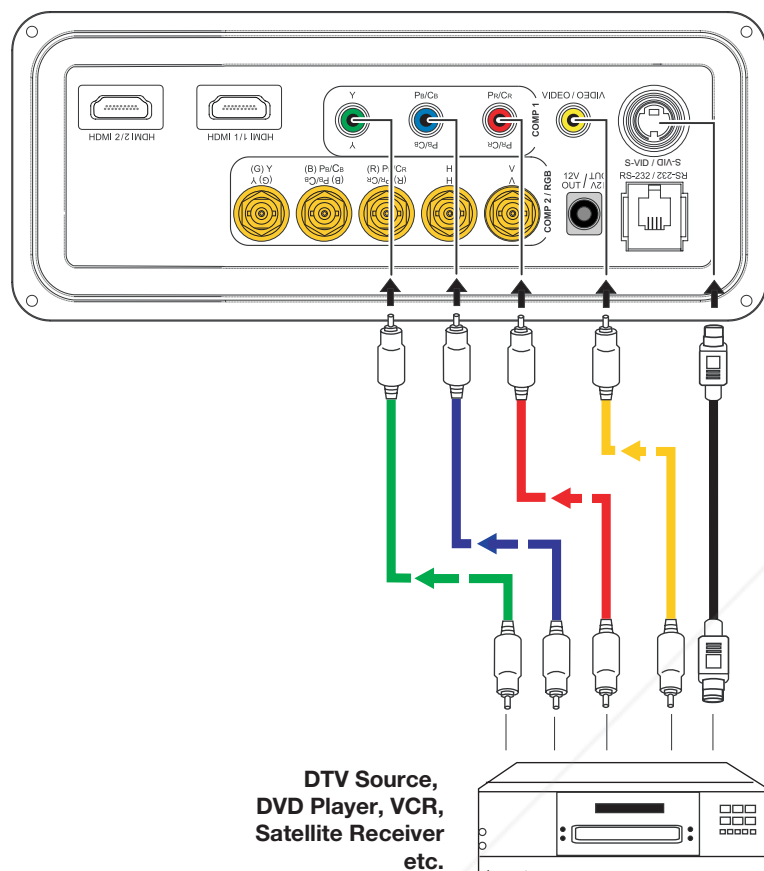
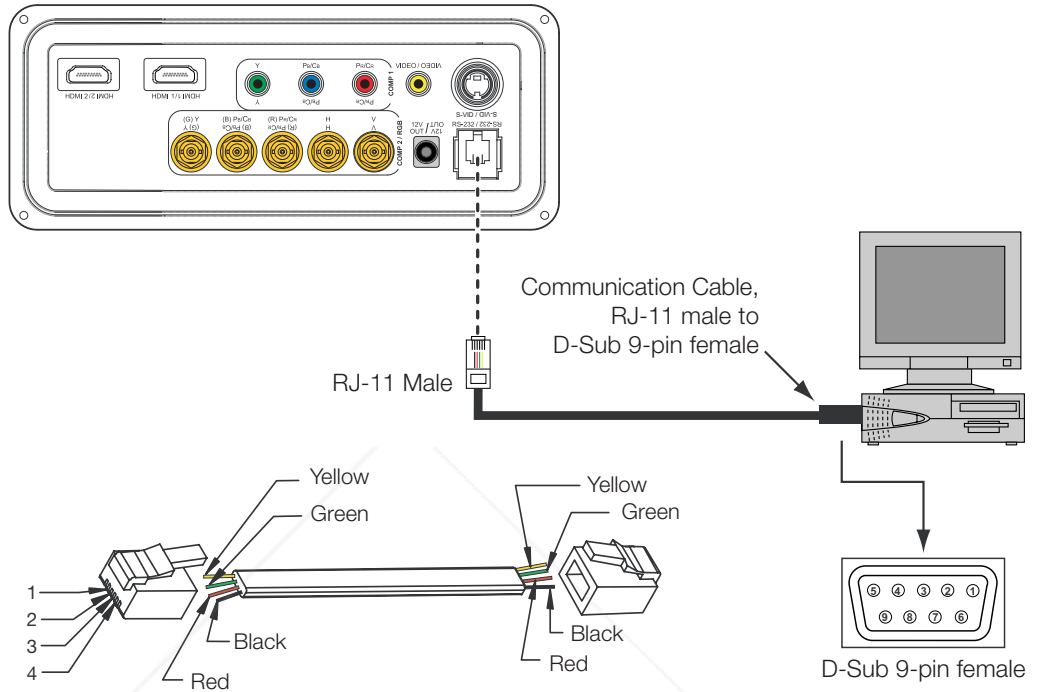

Figure 3-16. Composite, S-Video and Component Video Connections

RS-232 Controller Connection

Use a communication cable to connect a PC or home theater control/automation system (if present) to the RS-232 port on the VX-3000; see Figure 3-17.

For more information about using this connection, refer to **Serial Communications** on page 77.



RS-232 Adapter Wiring		
D-Sub 9-pin female	4-pin RJ-11	Function
2	2	Transmit Data
3	3	Receive Data
5	1, 4	Ground
1, 4, 6, 7, 8, 9	--	Not Connected

Figure 3-17. RS-232 Control System Connection

If you are installing a VX-3000i/CineWide with AutoScope, VX-3000d/CineWide with AutoScope or VX-3000 Ultra/CineWide with AutoScope, use the cable supplied with the AutoScope Lens Motor to connect the motor to the 12-volt trigger output as shown in Figure 3-18.

➤ **Connecting 12-Volt Trigger Output to External Theater Equipment**

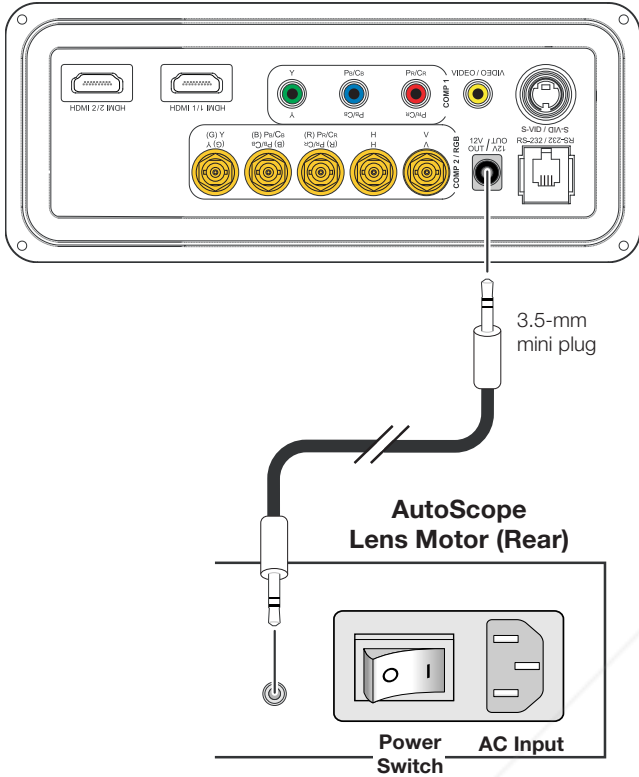

Figure 3-18. Connecting the 12-Volt Trigger Output to the AutoScope Lens Motor

If your home theater contains a retractable screen, screen mask or other 12-volt trigger-activated equipment, connect it to the 12-volt trigger output as shown in Figure 3-19.

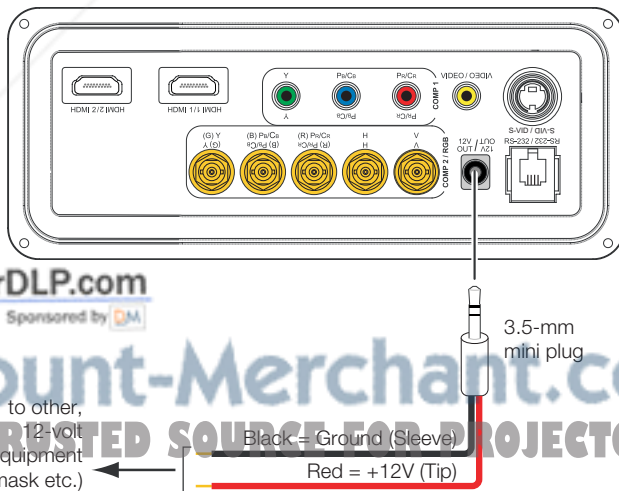

Figure 3-19. Connecting the 12-Volt Trigger Output to Other Equipment



Discount-Merchant.com (800) 281-8860
 THE TRUSTED SOURCE FOR PROJECTOR LAMPS AND ACCESSORIES

Connecting to AC Power ➤

Projector: The VX-3000 ships with various types of AC power cords. Choose the one that is appropriate to your locale.

Plug the female end of the power cord into the AC receptacle on the rear of the projector (AC 100V ~ 240V). Then, connect the other end to your AC power source.

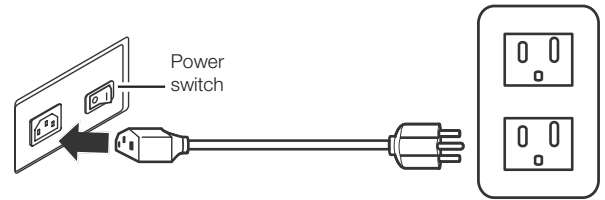

AutoScope Lens Motor: With AutoScope-equipped projectors, an additional power cord is provided for the lens motor. Plug the female end of the AC power cord into the AC input on the rear of the lens motor assembly. Connect the other end to a power source.

AutoScope Lens Motor (Rear)

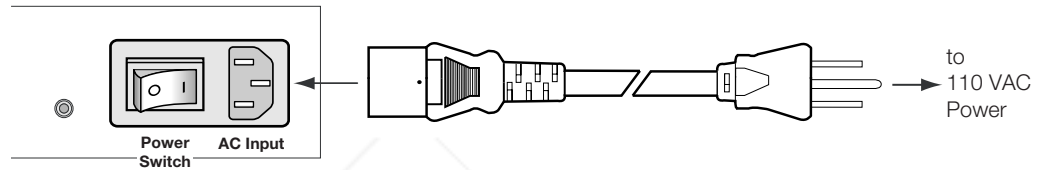

**3.8
Turning on the Power**

1. Turn on your source components.
2. If this is an AutoScope-equipped projector, turn on the main power switch at the rear of the AutoScope lens motor. The lens motor power switch is located next to the AC input (see above).
3. Turn on the main power switch at the rear of the projector. The POWER LED lights orange. The LAMP and TEMP LEDs light red briefly, then go out.
4. Press the **ON** button on the remote control to turn on the VX-3000. The POWER LED flashes green to indicate that it is warming up.
5. When the projector is ready for use, the POWER LED lights solid green.
6. “[Input Name] Source Searching” appears on the screen before the VX-3000 identifies the input signal and remains there until a valid signal is detected.



Discount-Merchant.com (800) 281-8860
THE TRUSTED SOURCE FOR PROJECTOR LAMPS AND ACCESSORIES

The VX-3000 gives you a great deal of control over the picture size, position and focus.

To focus the projected image, grasp the lens by the outer ring and rotate it.

To make the picture smaller (zoom out) or larger (zoom in), move the zoom tab in the appropriate direction.

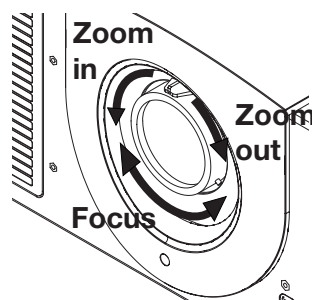

The VX-3000 Ultra has motorized focus and zoom controls. To access them, use the two, white buttons on the remote control to the left of the **LENS** button.

To focus the projected image, press the **FOCUS** button, then use the left- and right-arrow buttons (◀, ▶) to adjust the focus.

To make the picture smaller (zoom out), press the **ZOOM** button, then use the left-arrow (◀) button. To enlarge the picture (zoom in), press the **ZOOM** button, then use the right-arrow (▶) button.

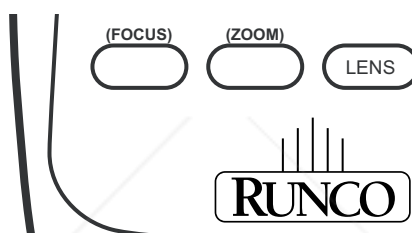

Vertical Lens Shift: To shift the projected image vertically, press the **LENS** button, then use the up and/or down-arrow (▲, ▼) buttons.

The VX-3000 OSD language is initially set to English, but can also display the menus in French, Spanish, Italian or German. To change the OSD language:

1. Press **MENU**.
2. Select **Installation** from the Main Menu and press **ENTER**.
3. Select **Language** from the Installation Menu.
4. Press ◀ or ▶ to select the desired language. (The change takes effect immediately.)

3.9 Primary Lens Adjustments

◀ Focus and Zoom

◀ Focus and Zoom – VX-3000 Ultra

◀ Lens Shift

3.10 Changing the OSD Language



Discount-Merchant.com (800) 281-8860
THE TRUSTED SOURCE FOR PROJECTOR LAMPS AND ACCESSORIES

3.11 Adjusting the Picture Orientation

By default, the VX-3000 is configured for a “floor/front” installation, in which the projector is installed upright and in front of the screen. If it is installed behind the screen and/or mounted on a ceiling, you must change the picture orientation. To do this:

1. Press **MENU** on the remote control.
2. Select Installation from the Main Menu and press **ENTER**.
3. Select Orientation from the Installation Menu.
4. Choose Floor Rear, Ceiling Front or Ceiling Rear to match the installation method.

3.12 Installing and Adjusting the CineWide Anamorphic Lens

If you are installing a CineWide-equipped projector, proceed as follows to install and adjust the anamorphic lens.



Note

It is extremely important that the primary lens is properly adjusted before you install the anamorphic lens. Ensure that the image from the primary lens is perfectly centered on the screen.

Runco offers two types of anamorphic lenses for its CineWide projectors: **prismatic** and **cylindrical**.

- The prismatic lens compresses the height of the image (as opposed to stretching the width) to achieve a 2.35:1 aspect ratio with a 1.78:1 display device.
- The cylindrical anamorphic lens has a larger aperture than the prismatic lens. It stretches the width of the image to achieve a 2.35:1 aspect ratio with a 1.78:1 display device. Two, cylindrical anamorphic lens options are available: Rainier II and McKinley. Although they differ in size and throw distance range (refer to Table 3-3), the installation procedure for both lenses is similar.

The following models are available with either a prismatic or a cylindrical anamorphic lens:

- VX-3000i/CineWide
- VX-3000d/CineWide
- VX-3000 Ultra/CineWide

The following models always use a cylindrical lens:

- VX-3000i/CineWide with AutoScope
- VX-3000d/CineWide with AutoScope
- VX-3000 Ultra/CineWide with AutoScope

If you are installing a CineWide projector with a prismatic lens, refer to **Whitney (Prismatic) Anamorphic Lens Installation and Adjustment** on page 50. If you are installing a CineWide projector with a cylindrical lens, continue with the next section.



Discount-Merchant.com (800) 281-8860
THE TRUSTED SOURCE FOR PROJECTOR LAMPS AND ACCESSORIES

The Cylindrical Anamorphic lens mount kit consists of everything shown in Figure 3-20. Some components shipped with your projector may differ slightly from what is shown in these instructions.

◀ Cylindrical Anamorphic Lens Installation and Adjustment

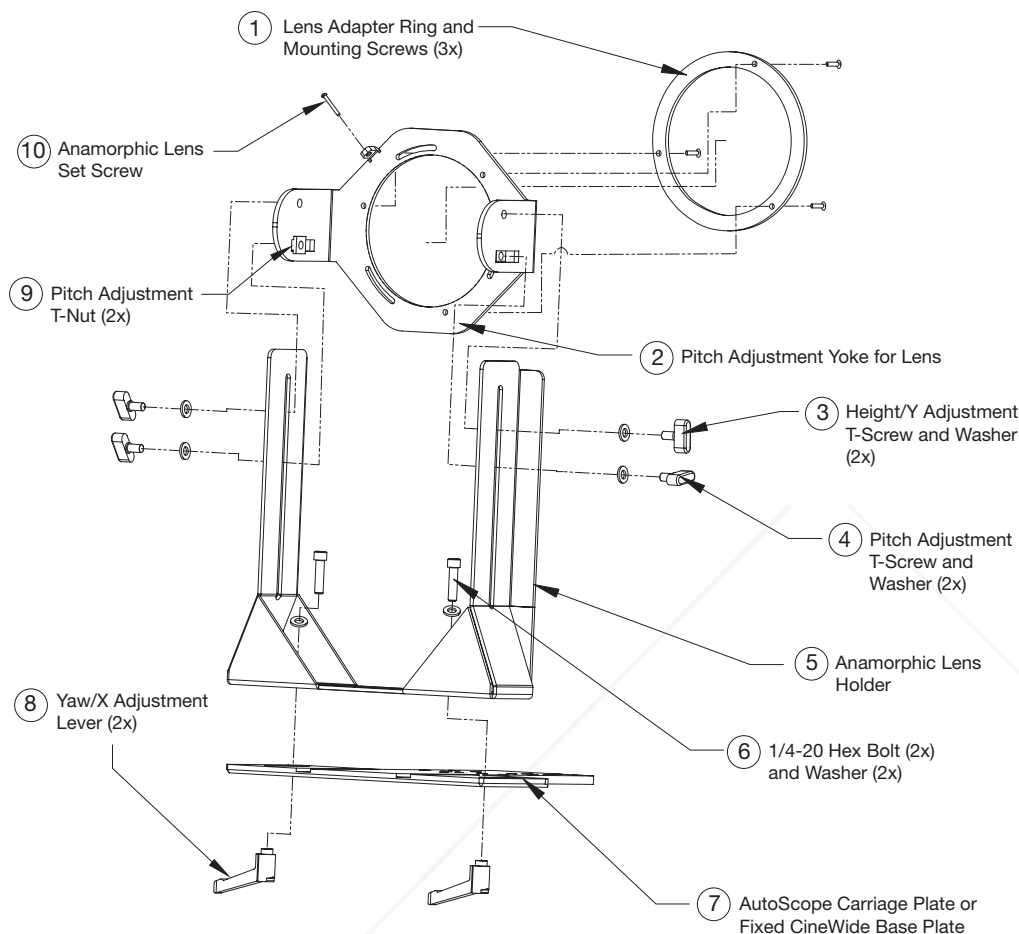

Figure 3-20. Cylindrical Anamorphic Lens Mounting Assembly - Exploded View

Attaching Lens Mounting Assembly to Lens Motor Carriage Plate or Fixed CineWide Base Plate:

1. Remove the two Yaw/X Adjustment Levers (item #8) from the bottom of the Anamorphic Lens Holder (item #5).
2. Place the Anamorphic Lens Holder on top of the AutoScope Carriage Plate or Fixed CineWide Base Plate (item #7). Position the bracket so that the long slot at the bottom of the lens holder is perpendicular to the corresponding slots on the plate.
3. Secure the Anamorphic Lens Holder to the plate using the Hex Bolts/Washers (item #6) and Yaw/X Adjustment Levers that you removed in Step 1.
4. Use the Lens Mounting Screws to attach the Lens Adapter Ring (item #1) to the Pitch Adjustment Yoke (item #2); see Figure 3-21. (Use the round, threaded holes on the yoke).

5. Use the Height/Y Adjustment T-Screws/Washers (item #3), Pitch Adjustment T-Screws/Washers (item #4) and T-Nuts (item #9) to attach the Pitch Adjustment Yoke and Lens Adapter Ring to the Anamorphic Lens Holder. **The Yoke should be as close to the primary lens as possible.**
6. Attach the lens to the Lens Adapter Ring by threading it clockwise.

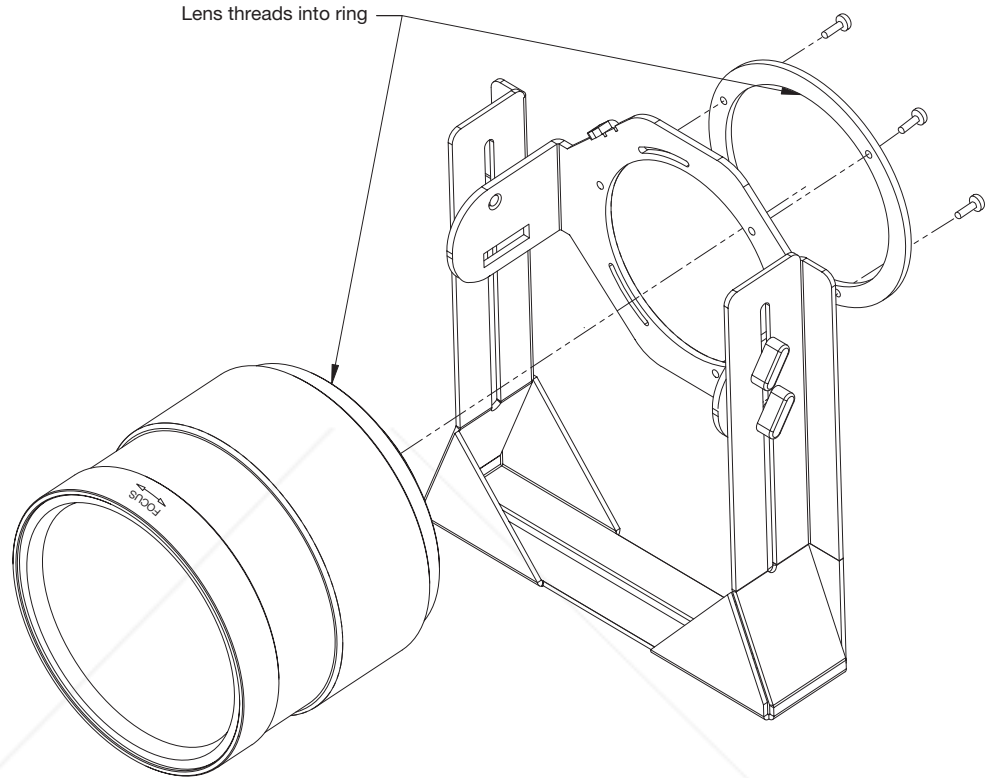

Figure 3-21. Attaching the Anamorphic Lens to the Lens Ring

Configure Lens Motor Trigger: CineWide with AutoScope maintains constant image height independent of the aspect ratio, while using the full display resolution of the projector. It accomplishes this by moving the anamorphic lens in front of the primary lens when widescreen material is being viewed. When the viewer transitions back to 16:9 or 4:3 source material, the anamorphic lens moves out of the light path.

To configure the lens motor trigger on the VX-3000 for proper AutoScope operation:

1. Press **MENU** on the remote control.
2. Select Setup from the Main menu and press **ENTER**.
3. Use the number buttons on the remote to enter the Setup menu passcode when prompted and press **ENTER** again. Then, press **MENU** on the remote control.
4. Select 12-volt Trigger from the Setup menu.
5. Set the 12-volt Trigger to "Cinema." This enables the lens motor to move the anamorphic lens into position (in front of the primary lens) when the Cinema or Virtual Cinema aspect ratio is selected.

6. Select the Cinema or Virtual Cinema aspect ratio to move the anamorphic lens into position, if it isn't already. To do this, press **CINEMA** or **VCINE** on the VX-3000 remote control (Figure 2-4).

Adjusting the Horizontal (X) Lens Position:

1. Project a white field on the screen.
2. Loosen the Yaw/X-Adjustment Levers underneath the lens.
3. Slowly move the anamorphic lens into place (from right to left or vice versa) so that there are no shadows on either side of the screen:

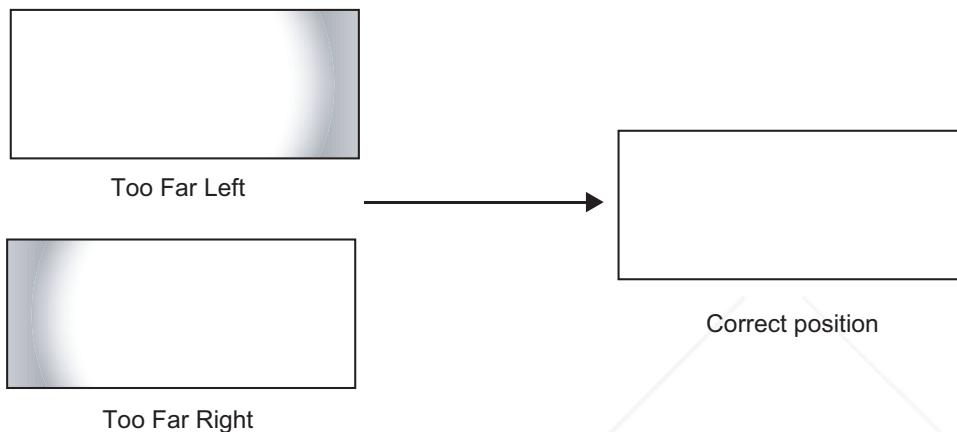

4. When the horizontal position is properly set, tighten the Yaw/X-Adjustment Levers to secure the lens in place.

Adjusting the Height (Y): With the white field still on-screen, loosen the Height/Y Adjustment T-Screws on either side of the lens. Then, slowly move the anamorphic lens into place so that there are no shadows on the top or bottom of the screen:

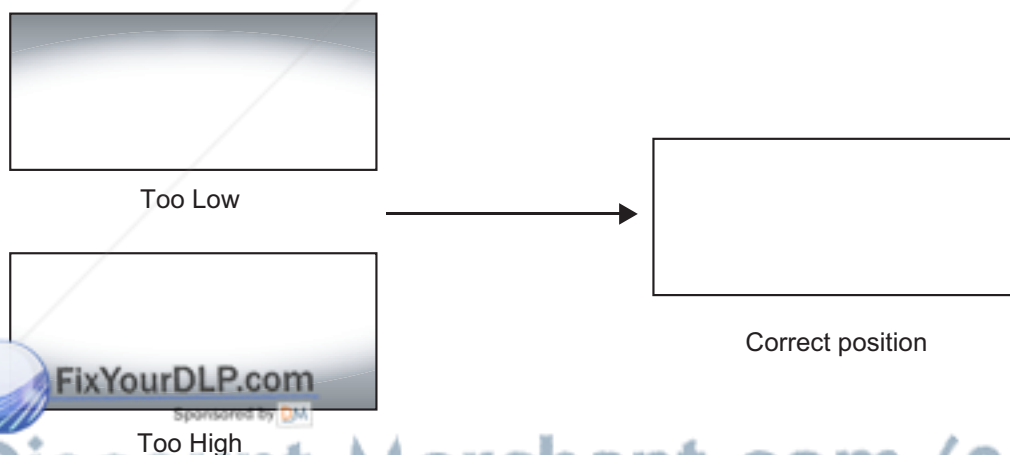

When the height is properly set, tighten the Height Adjustment T-Screws to secure the lens in place.

Adjusting the Pitch (Angle): Next, angle the lens to even out any top-to-bottom pincushion distortion. To do this, loosen the Pitch Adjustment T-Screws (directly below the Height/Y Adjustment T-Screws) on either side of the lens to allow it to pivot freely. Then, adjust the anamorphic lens angle so that the projected image is rectangular:

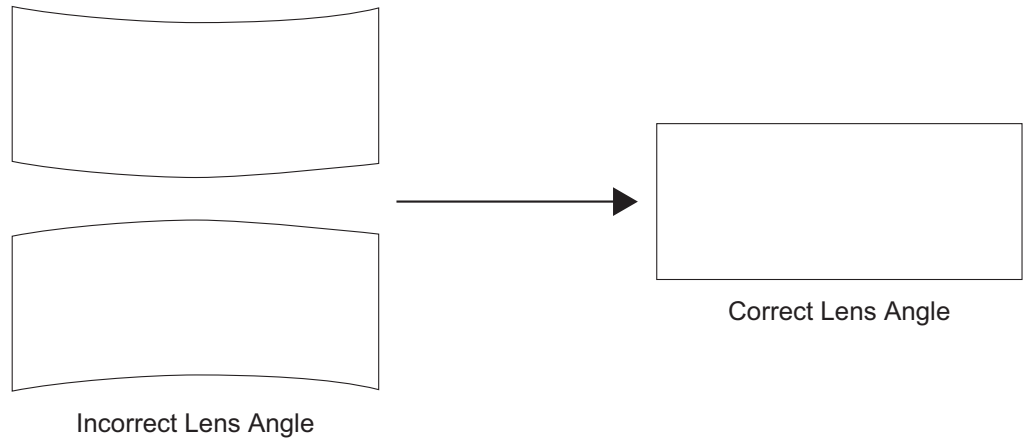

The anamorphic lens will almost always be angled with respect to the projector; this is normal.

Once the proper lens angle has been set, firmly tighten the Pitch Adjustment T-Screws to secure the lens in place.



Note

There may be some pincushion distortion even after the lens is properly adjusted, especially at shorter throw distances. If this is the case, Runco recommends that you slightly over-scan the image into the screen frame area to mask the distortion.

Adjusting the Yaw: Loosen the Yaw/X-Adjustment Levers to allow the lens to pivot freely from side to side. Then, angle the lens to even out any left-right pincushion distortion:

Anamorphic Lens (Top View)

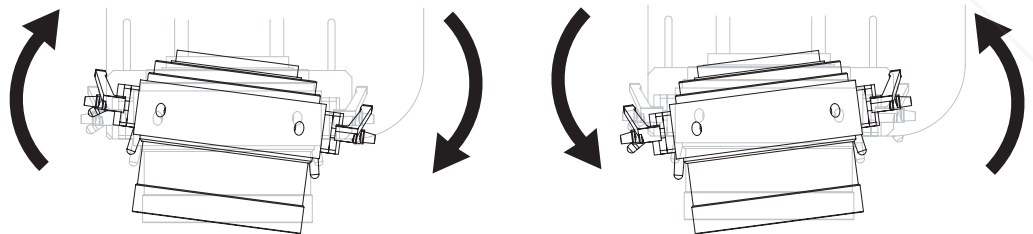

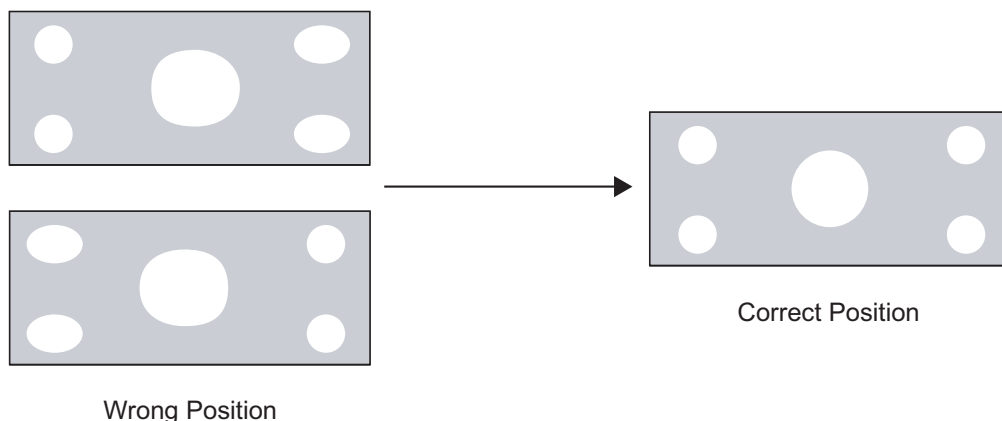

Once the proper lens angle has been set, firmly tighten the Yaw/X-Adjustment Levers to secure the lens in place.

Geometry:

1. Input an anamorphic cross-hatch test pattern to the projector.
2. Unscrew the Anamorphic Lens just enough to allow it to rotate freely.
3. Grasp the lens by the center ring and rotate the lens until the image is properly anamorphic:

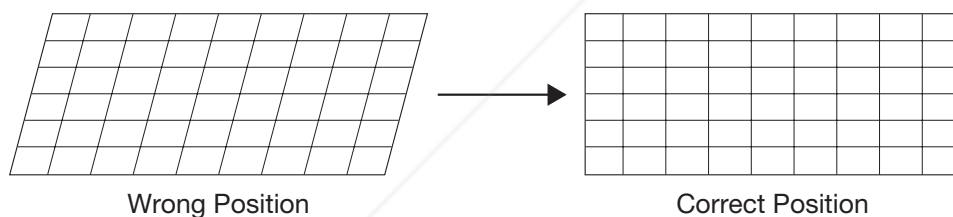

4. When the image geometry appears correct, tighten the Anamorphic Lens Set Screw (item #10) to secure the lens in place. (When viewed from the front, the rear opening on the anamorphic lens should appear as a tall, narrow oval.)

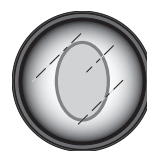

Focus: Finally, rotate the Focus Ring on the anamorphic lens to fine-tune the optical focus.



Discount-Merchant.com (800) 281-8860
THE TRUSTED SOURCE FOR PROJECTOR LAMPS AND ACCESSORIES

**Whitney (Prismatic)
Anamorphic Lens
Installation and
Adjustment**

The Whitney Anamorphic lens mount kit consists of everything shown in Figure 3-22. Some components shipped with your projector may differ slightly from what is shown in these instructions.

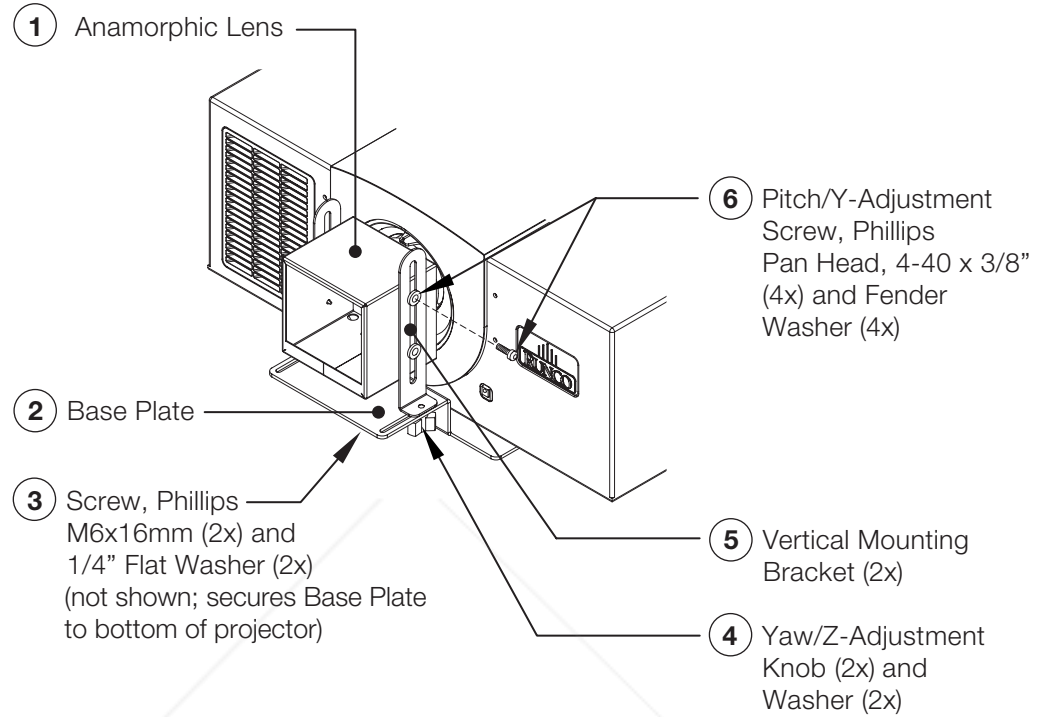

Figure 3-22. Prismatic Anamorphic Lens Mounting Assembly - Exploded View

1. Use the Pitch Adjustment Screws and Washers (item #6) to attach the Vertical Mounting Brackets (item #5) to the Anamorphic Lens (item #1).
2. Place the lens with the brackets installed on top of (or under, if the projector is inverted) the Base Plate (item #2), so that the two threaded posts at the bottom of the brackets pass through the corresponding slots on the base plate.
3. Secure the lens assembly to the base plate with the Yaw/Z-Adjustment Knobs and Washers (item #4).



Tip

To avoid clipping the corners of the image, position the anamorphic lens as close as possible to the primary lens.

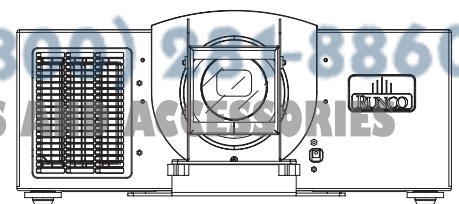
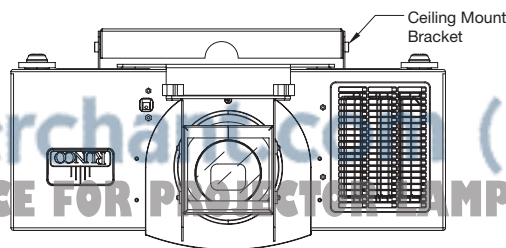

Discount-Merchants.com (800) 904-8860
THE TRUSTED SOURCE FOR PROJECTOR PARTS & ACCESSORIES

Adjusting the Lens Height (Y):

1. Project a white field on the screen.
2. Ensure that the four Height (Y) Adjustment Screws are loose enough to allow vertical movement of the lens assembly.
3. Slowly move the anamorphic lens into place so that there are no shadows on the top or bottom of the screen:

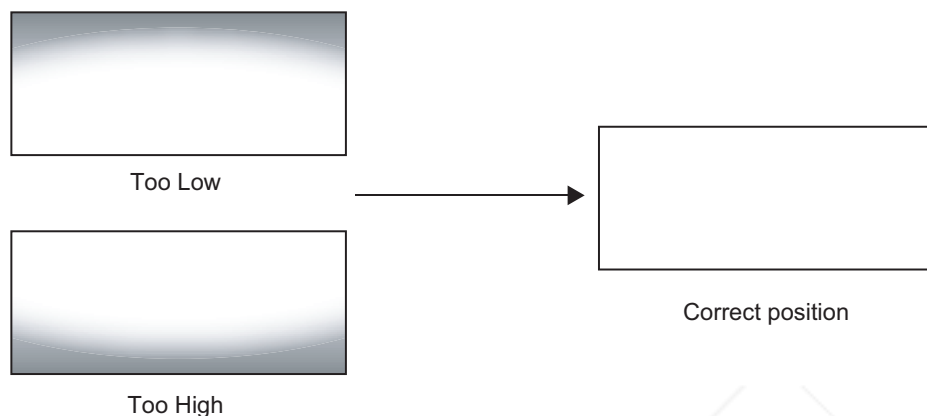

4. When the height is properly set, tighten the Height Adjustment Screws to secure the lens in place.

Adjusting the Pitch (Angle): Next, angle the lens to even out any top-to-bottom pincushion distortion. To do this, loosen the Pitch Adjustment Screws on either side of the lens to allow it to pivot freely. Then, adjust the anamorphic lens angle so that the projected image is rectangular:

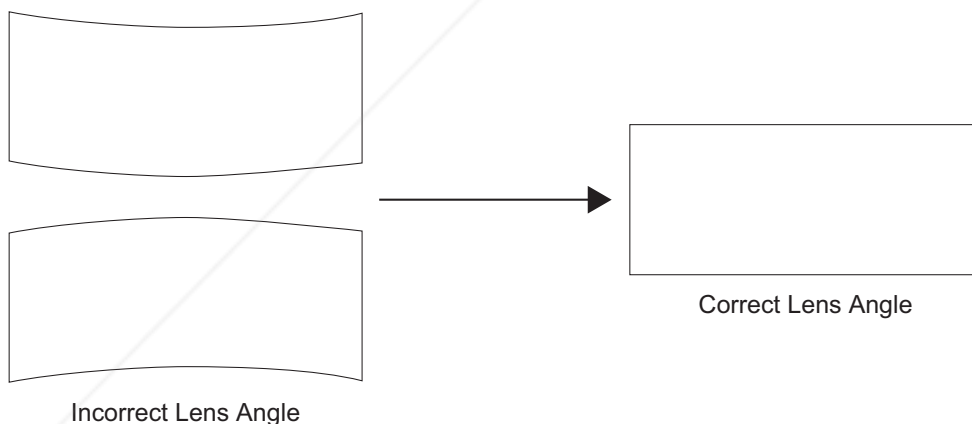

The anamorphic lens will almost always be angled with respect to the projector; this is normal.

Once the proper lens angle has been set, firmly tighten the Pitch Adjustment Screws to secure the lens in place.



Note

There may be some pincushion distortion even after the lens is properly adjusted, especially at shorter throw distances. If this is the case, Runco recommends that you slightly over-scan the image into the screen frame area to mask the distortion.

Adjusting the Yaw: Loosen the Yaw/Z-Adjustment Knobs to allow the lens to pivot freely from side to side. Then, angle the lens to even out any left-right pincushion distortion:

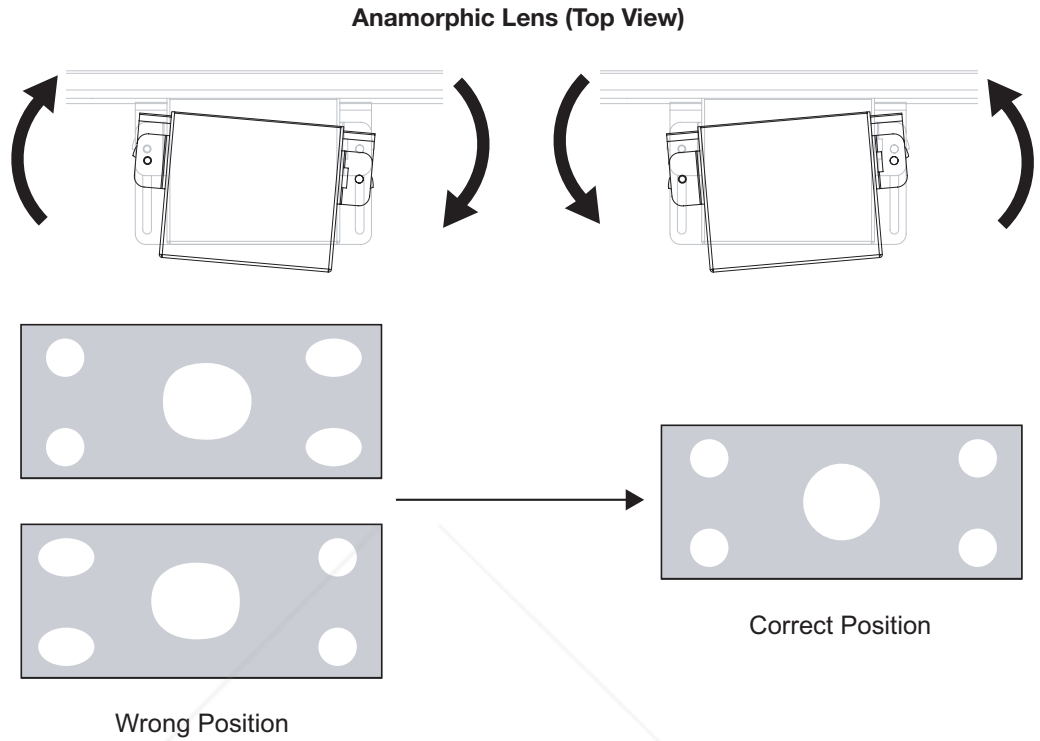

Once the proper lens angle has been set, firmly tighten the Yaw/Z-Adjustment Knobs to secure the lens in place.

4. Operation

- Press the **CUST1** or **CUST2** button on the remote control to recall settings for the current input from the “Custom 1” or “Custom 2” memory preset.
- Press **ISF NIGHT** to recall settings for the current input from the “ISF Night” memory preset.
- Press **ISF DAY** to recall settings for the current input from the “ISF Day” memory preset.



4.1 Selecting Video Memory

Use these buttons to select the appropriate aspect ratio for the type of program material being viewed. For more information on aspect ratios, refer to Table 4-1.

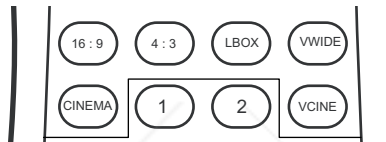

4.2 Selecting an Aspect Ratio

- Press the **BRT** button on the remote control to adjust the image brightness.
- Press **CONT** to adjust the image contrast.
- Press **COL** to adjust the image color level.
- Press **TINT** to adjust the hue of the image.



4.3 Adjusting the Picture

For more information about these controls, refer to **Picture Adjust** on page 56.

When you turn on the VX-3000, it switches to the last selected input and looks for a valid signal.

Use these buttons on the remote control to select an input source directly.

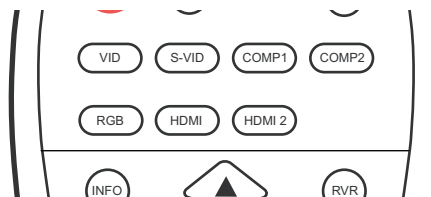

4.4 Selecting An Input Source



Discount-Merchant.com (800) 281-8860
THE TRUSTED SOURCE FOR PROJECTOR LAMPS AND ACCESSORIES

4.5 Using Picture-In-Picture (PIP)

For PIP purposes, there are two groups of inputs separated by their display modes:

- **Video (SD) group:** Video and S-Video inputs.
- **Graphic (HD) group:** HDMI 1, HDMI 2, Component 1 and Component 2/RGB inputs.

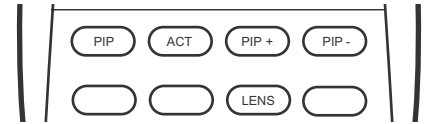

PIP shows one input from the Graphic group within one input from the Video group, or vice versa.

- Press **PIP** to enable the PIP function. Press **PIP** again to turn PIP off.
- To adjust the size of the PIP window, press **PIP+** or **PIP-**.
- When PIP is active, press **ACT** (Active) to display the Main and Secondary source menu.

PIP	
Main	Secondary
> Video	Video
S-Video	S-Video
Component 1	> Component 1
Component 2	Component 2
HDMI 1	HDMI 1
HDMI 2	HDMI 2
RGB HD	RGB HD

To select a main window input source, press ▲ or ▼ to highlight it and press **ENTER**. Then, do the same for the secondary window input source using the ►, ▲, ▼ and **ENTER** buttons. When finished, press **EXIT**.

4.6 Using the On-Screen Menus

- Press the **MENU** button on the remote control to display the Main Menu. To select a menu item, use the ▲ and ▼ buttons on the remote control to highlight it. Press **ENTER** or ► to confirm your selection.
- Use the arrow buttons to select menu items or change settings.
- Press **EXIT** to return to the previous menu.
- Press **MENU** to turn off the OSD menu. (When the Main Menu is displayed, pressing **EXIT** also turns off the menu.)

The VX-3000 OSD menus are arranged hierarchically, as shown in Figure 4-1. Depending on the selected input source and signal characteristics, some menu options may not be available.

Source Select	Video			
	S-Video			
	Component 1			
	Component 2			
	HDMI 1			
	HDMI 2			
	RGB HD			
Picture Adjust	Picture Memory Copy Settings	ISF Night, ISF Day, Custom 1 or Custom 2		
	Brightness	0 ... 100		
	Contrast	0 ... 100		
	Color	0 ... 100		
	Tint	0 ... 100		
	Sharpness	0 ... 8		
	Color Temperature	5400 K, 6500 K, 9300 K, Custom 1 or Custom 2		
Aspect Ratio	16:9			
	4:3			
	Letterbox			
	Virtual Wide			
	Cinema			
	Virtual Cinema	(available only on VX-3000 projectors equipped with the CineWide option)		
Installation	Language	English, French, Spanish, German or Italian		
	Orientation	Floor Front, Floor Rear, Ceiling Front or Ceiling Rear		
	GeoCorrection	V. Keystone		
		H. Keystone		
		Pincushion		
	Overscan	0 ... 3		
	HD & RGB Adjust (480p and higher-res. signals only)	Auto		
		Frequency	0 ... 100	
		Phase	-15, -14 ... 0 ... +14, +15	
		H. Position		
		V. Position	0 ... +30	
	OSD Setup	OSD Timer	0, 3, 6, 9 ... 60 sec.	
		OSD Position	Horizontal Vertical	
	Blue Image	On / Off		
	Sleep Timer	0, 30, 60, 90 ... 360 min.		
Source				
Resolution				
Aspect Ratio			(read only)	
Picture Memory				
Lamp Hours				
Serial				
Setup	Lamp Power	170W or 200W		
	Lamp Hours	View / Reset		
	Fan Mode	Normal, Hi. Altitude or Manual	Speed (if Manual mode is selected)	
	Background Color	Black, Blue or Gray		
	PIP	On / Off		
	RVR	0, 1, 2 ... 19		
	12-volt Trigger	Normal or Cinema		
	V. Correction	0 ... 8		
	Amplitude	Horizontal	0 ... 8	
		Vertical	0 ... 4	
Auto Off	5, 10 ... 30 or Off			
Default	Yes / No			
ISF	Picture Memory Copy Settings	ISF Night, ISF Day, Custom 1 or Custom 2		
	Brightness	0 ... 100		
	Contrast	0 ... 100		
	Color	0 ... 100		
	Tint	0 ... 100		
	Sharpness	0 ... 8		
	Color Temperature	5400 K, 6500 K, 9300 K, Custom 1 or Custom 2		
	White Balance (available only when Custom 1 or Custom 2 color temp. is selected)	Gain		
		Offset		Red / Green / Blue
	Advanced Options	Image Enhance		DNR
				Detail Enhance
				Luma Enhance
				Chroma Enhance
Black Threshold			0 IRE or 7.5 IRE	
Gamma Selection		2.8, 2.6, 2.5, 2.4 or 2.2		
Advanced Color Enhance (ACE)		R / G / B / Y / C / M Limit / Saturation		
Gamut		(refer to page 71)		
Reset to Defaults	Yes / No			

Figure 4-1. VX-3000 OSD Menu Structure

Discount-Merchant.com (800) 281-8860
THE TRUSTED SOURCE FOR PROJECTOR LAMPS AND ACCESSORIES

Main Menu ➤ The Main Menu is the starting point for accessing all projector functions. (You must enter a passcode to access the Setup and ISF menus.)

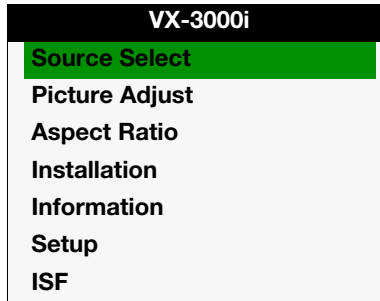

Source Select ➤ Choose Source Select from the Main Menu to switch video sources.

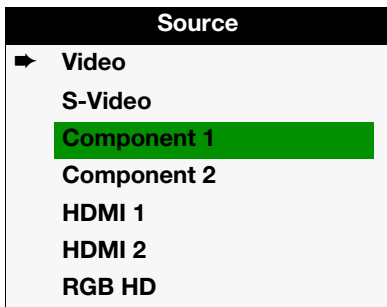

The active source is indicated by an arrow to its left; in this example, Video is the active source. To select a different source, use the ▲ or ▼ button to highlight it and press **ENTER**.

Picture Adjust ➤ Use the controls in the Picture Adjust menu to calibrate your VX-3000 for optimum picture quality. To access the Picture Adjust menu, press **MENU**, highlight Picture Adjust and press **ENTER**.

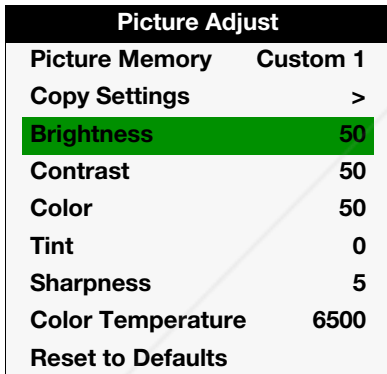

To adjust a setting, use the ▲ or ▼ button to highlight it and press **ENTER**. Use the ◀ or ▶ button to change the setting. When finished, press **EXIT**.

The VX-3000 has been designed to incorporate setup and calibration standards established by the Imaging Science Foundation (ISF). The ISF has developed carefully crafted, industry-recognized standards for optimal video performance and has implemented a training program for technicians and installers to use these standards to obtain optimal picture quality from Runco video display devices. Accordingly, Runco recommends that setup and calibration be performed by an ISF certified installation technician.

All signal types require separate processing. Therefore, you need to calibrate each input separately.

Although it may be possible to obtain satisfactory picture quality using the naked eye and regular program material, Runco recommends using the following calibration tools for best results:

- External test pattern source – Ovation Multimedia, Digital Video Essentials or AVIA test DVD or equivalent.
- A blue filter (provided with many test DVDs), for color level and tint adjustments.

Connect your test pattern source to the input that you are calibrating and proceed as follows. **Perform the adjustments in the order listed here.**

Picture Memory: For each input, the VX-3000 lets you store picture quality settings as presets that you can recall at a later time. You can create up to four presets per input and resolution, to accommodate changing lighting conditions or viewer preferences.

To select a picture memory preset, highlight Picture Memory in the Picture Adjust menu. Then, press ◀ or ▶ to select “Custom 1,” “Custom 2,” “ISF Night” or “ISF Day.” When you select “Custom 1” or “Custom 2,” any changes to picture quality settings are stored in the selected preset.

**Note**

1. To store changes to the ISF Night or ISF Day Picture Memory preset, select that Picture Memory in the ISF menu (refer to **ISF** on page 69). **You must enter a passcode to access the ISF menu.**
2. The Picture Memory selection you make here is not retained when the projector is powered off, then on again. To specify which Picture Memory should take effect when the projector is powered on, select it in the ISF menu.

Copy Settings: When you select the “Custom 1” or “Custom 2” Picture Memory preset, you can copy the settings from another preset to the selected preset. This gives you a convenient starting point for creating a new, custom preset. To do this, select Copy Settings from the Picture Adjust menu and press ▶. Then, choose “Custom 1,” “Custom 2,” “ISF Night” or “ISF Day.”

**Note**

To copy changes to the ISF Night or ISF Day Picture Memory preset, select that Picture Memory in the ISF menu (refer to **ISF** on page 69). **You must enter a passcode to access the ISF menu.**

Brightness: On your external test pattern source, select a PLUGE pattern. (PLUGE is an acronym for “Picture Line-Up Generation Equipment.”) Figure 4-2 shows a typical PLUGE pattern.

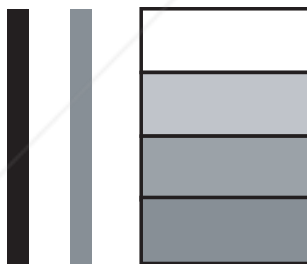

Below Black

FixYourDLP.com

Above Black

Sponsored by DMI

Figure 4-2. Typical PLUGE Pattern for Adjusting Brightness

PLUGE patterns vary but generally consist of some combination of black, white and gray areas against a black background. The example above includes two vertical bars and four shaded boxes.

Select Brightness from the Picture Adjust menu and press **ENTER**. Adjust the level so that:

- The darkest black bars disappear into the background.
- The dark gray areas are barely visible.
- The lighter gray areas are clearly visible.
- The white areas are a comfortable level of true white.
- The image contains only black, gray and white (no color).

Contrast: On your external test pattern source, select a stepped, gray-bar pattern like the one shown in Figure 4-3.



Figure 4-3. Typical Gray Bar Pattern for Adjusting Contrast

Select Contrast from the Picture Adjust menu and press **ENTER**. Adjust the contrast to a point just below which the white rectangle starts to increase in size.



Note

Brightness and Contrast controls are interactive. A change to one may require a subtle change to the other in order to achieve the optimum setting.

Color: On your external test pattern source, select a color bar pattern like the one shown in Figure 4-4.

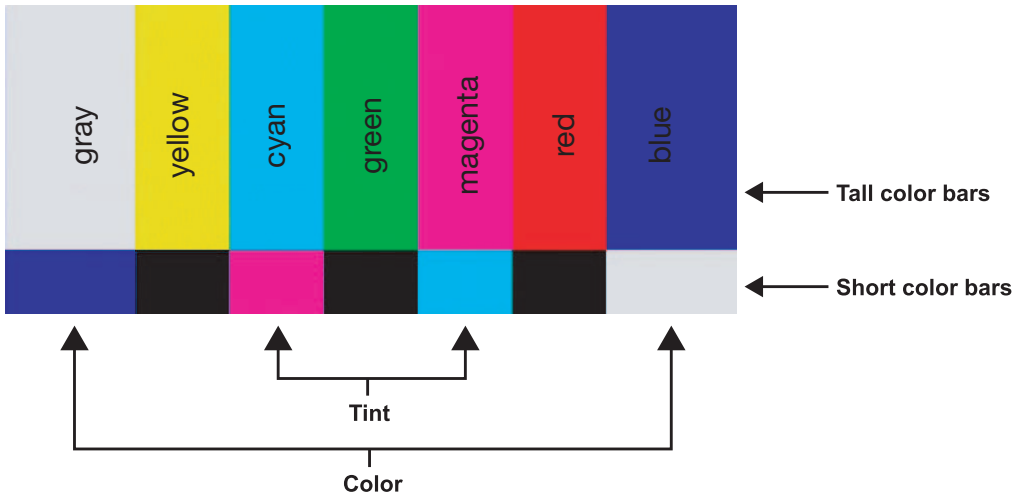
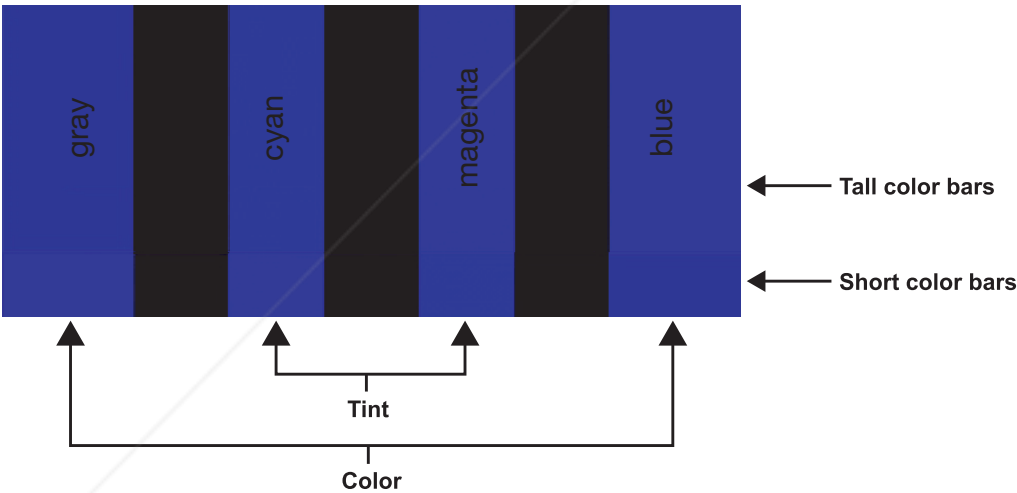

Figure 4-4. Typical Color Bar Pattern for Adjusting Color Saturation and Tint

Select Color from the Picture Adjust menu and press **ENTER**. While looking at the color bar pattern through a blue filter, adjust the color saturation level until the outermost (gray and blue) color bars appear to be a single shade of blue:



Tint: Tint or “hue” is essentially the ratio of red to green in the color portion of the image. When tint is decreased, the image appears redder; when it is increased the image appears greener. To set the tint, select Tint from the Picture Adjust menu and press **ENTER**. While looking at the color bar pattern through a blue filter, adjust the tint level until the cyan and magenta color bars (on either side of the green bar) appear to be a single shade of blue.



Note

Like the Brightness and Contrast controls, the color and tint controls are interactive. A change to one may require a subtle change to the other in order to achieve the optimum setting.

Sharpness: “Sharpness” is the amount of high-frequency detail in the image. To adjust sharpness, select Sharpness from the Picture Adjust menu and press **ENTER**. On your external test pattern source, select a pattern like the one shown in Figure 4-5. Adjust as needed, looking for white edges around the transitions from black to gray and differently-sized lines in the “sweep” patterns at the top and bottom. Lower the sharpness setting to eliminate them.

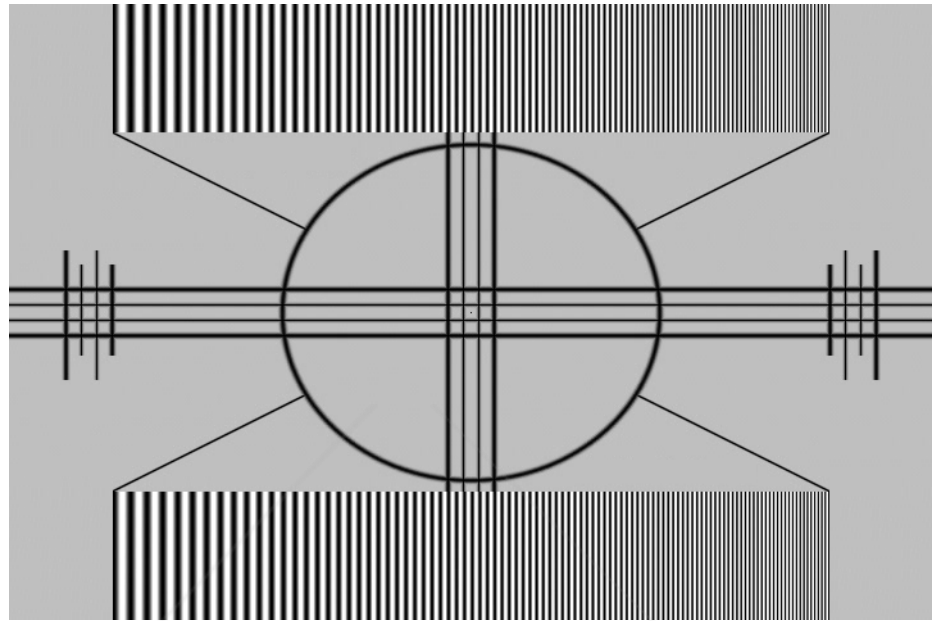
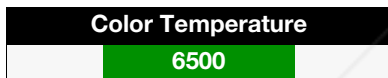

Figure 4-5. Typical Test Pattern for Adjusting Sharpness



Color Temperature: The VX-3000 has five memory settings for Color Temperature:

- 5400 kelvins
- 6500 kelvins
- 9300 kelvins
- Custom 1
- Custom 2

Custom 1 and Custom 2 are installer-adjustable and can be used to create custom settings. There are six (6) adjustable “white balance” parameters available for the Custom 1 and Custom 2 settings (two each for red, green and blue). These are described later in this section; refer to **White Balance** on page 69.



Note

You must enter a passcode to access the ISF menu.

Reset to Defaults: To reset all picture quality settings for the current input to their factory-default values, select Reset to Defaults from the Picture Adjust menu.

To change the aspect ratio (size and shape) of the projected image, select Aspect Ratio from the Main Menu and press **ENTER**. Select the appropriate aspect ratio for your screen size and the type of program material being viewed, then press **ENTER**; refer to Table 4-1.

◀ **Aspect Ratio**

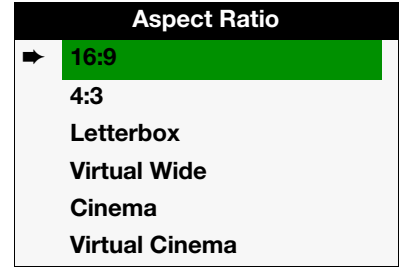
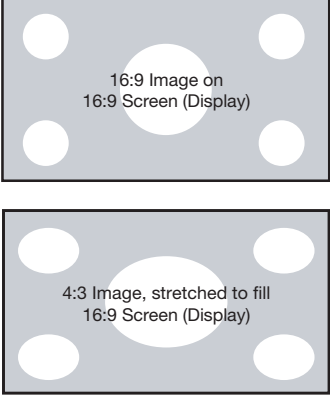
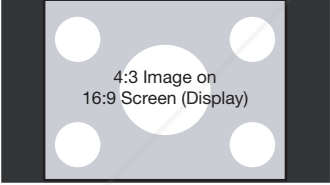
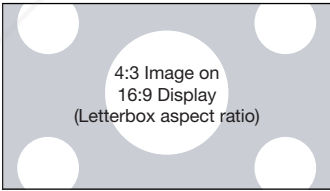

Table 4-1. Aspect Ratio Settings

Aspect Ratio	Remote Control Key	Description	
16:9	16 : 9	 <p>16:9 Image on 16:9 Screen (Display)</p> <p>4:3 Image, stretched to fill 16:9 Screen (Display)</p>	<p>Select 16:9 to view 16:9 DVDs and HDTV programs in their native aspect ratio.</p> <p>4:3 images are stretched horizontally to fit a 16:9 screen.</p>
4:3	4 : 3	 <p>4:3 Image on 16:9 Screen (Display)</p>	<p>4:3 scales the input signal to fit in the center of the 16:9 screen. 4:3 is the aspect ratio used by computer monitors, standard television programming and most VHS video cassettes.</p>
Letterbox	LBOX	 <p>4:3 Image on 16:9 Display (Letterbox aspect ratio)</p>	<p>Letterbox mode scales (zooms in on) a 4:3 image linearly (by the same amount on all sides) to fill a 16:9 display. Letterbox is best suited for viewing LaserDisc movies or non-anamorphic DVDs on a 16:9 screen.</p>



Discount-Merchant.com (800) 281-8860
THE TRUSTED SOURCE FOR PROJECTOR LAMPS AND ACCESSORIES

Table 4-1. Aspect Ratio Settings (continued)



Aspect Ratio	Remote Control Key	Description	
VirtualWide	VWIDE	 <p>The first diagram shows a 4:3 image on a 16:9 screen with black bars on the sides. The second diagram shows the same 4:3 image on a 16:9 screen with VirtualWide, where the image is stretched horizontally. The third diagram shows the 4:3 image on a 2.35:1 screen with VirtualWide, where the image is centered between black bars on either side.</p>	<p>VirtualWide scales a 4:3 image NON-linearly (more on the sides than in the center) to fit a 16:9 screen.</p> <p>On a 2.35:1 screen, the image is centered between black bars on either side.</p>
Cinema	CINEMA	 <p>The first diagram shows a 2.35:1 image on a 16:9 screen in Cinema mode, with black bars at the top and bottom. The second diagram shows the 2.35:1 image on a 2.35:1 screen in Cinema mode, where the image fills the screen.</p>	<p>Select Cinema to view 2.35 source material in its native aspect ratio.</p> <p>With a 16:9 screen and a non-CineWide projector (no anamorphic lens), the upper and lower portions of the screen are masked, but the geometry of the active image area is unchanged.</p> <p>With a 2.35:1 screen and a CineWide-equipped projector, the video processor scales the 2.35:1 image so that the active image area fills the 16:9 chip surface, eliminating the black bars. The secondary, anamorphic lens then restores the proper geometry to the 2.35:1 image.</p>

Table 4-1. Aspect Ratio Settings (continued)

Aspect Ratio	Remote Control Key	Description	
Virtual Cinema	VCINE	 	<p>A 16:9 image is scaled NON-linearly (more on the sides than in the center) to fit a 2.35:1 screen.</p> <p>Virtual Cinema is available only on VX-3000 projectors equipped with the CineWide option.</p>

To access the Installation adjustments, press **MENU**, then press the ▲ or ▼ button to highlight Installation and press **ENTER**. The Installation sub-menu appears. Press **EXIT** to return to the previous menu or press **MENU** to close all menus.

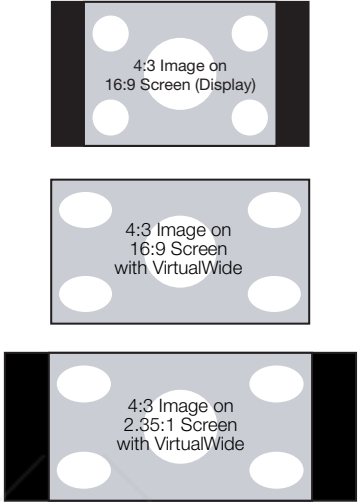

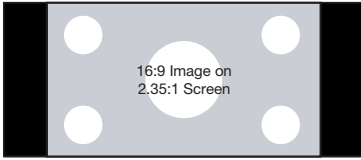
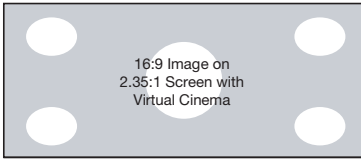
Note

*When you change a setting in the Installation menu, the change takes effect immediately; you do not need to press **ENTER** afterwards. (Press **EXIT** to return to the previous menu or **MENU** to exit.)*

Language: Press the ◀ or ▶ button to select from the available languages: English, French, Spanish, German and Italian.

Orientation: Press the ◀ or ▶ button to change the orientation of the projected image. The VX-3000 can be installed on a ceiling or in a rear-screen configuration with one or more mirrors. There are four settings: Floor Front, Ceiling Front, Floor Rear and Ceiling Rear.

◀ **Installation**

Installation	
Language	English
Orientation	Floor Front
GeoCorrection	>
Overscan	<input type="checkbox"/> 0
Blue Image	Off
Sleep Timer	Off



Discount-Merchant.com (800) 281-8860
THE TRUSTED SOURCE FOR PROJECTOR LAMPS AND ACCESSORIES

GeoCorrection		
V. Keystone	<input type="range"/>	0
H. Keystone	<input type="range"/>	0
Pincushion	<input type="range"/>	0

GeoCorrection: Projector placement and other factors can cause geometric distortion in the projected image. To correct this, select GeoCorrection from the Installation menu. This sub-menu provides the following options:

- **V. Keystone/H. Keystone:** To correct distortion resulting from the angle of projection, select V. Keystone or H. Keystone from the GeoCorrection menu and use the ◀ or ▶ button to make the image rectangular. See Figure 4-6.



Tip

Runco recommends that the keystone feature not be used unless absolutely necessary, as it may cause artifacts in the image.

Horizontal Keystone Correction

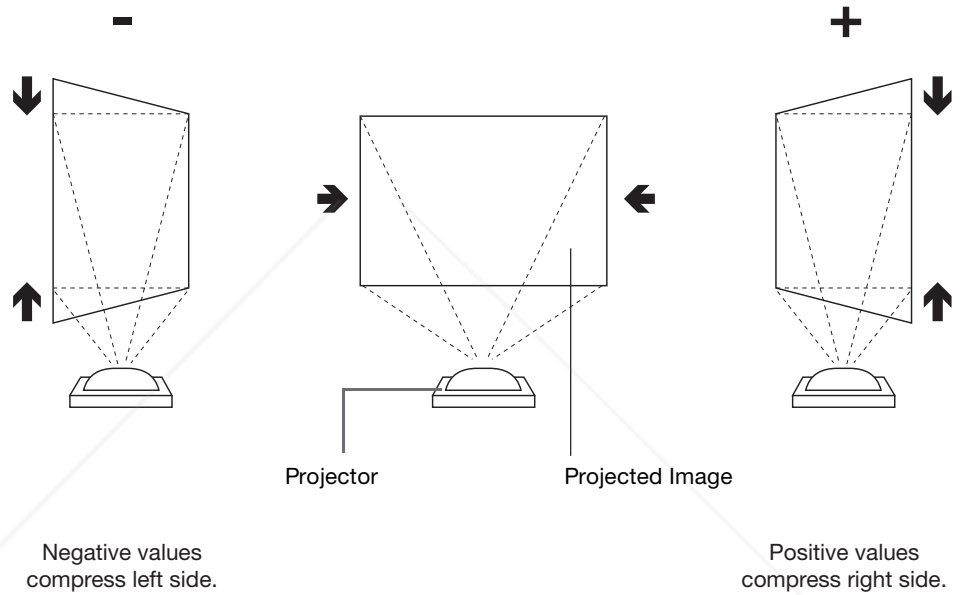

Vertical Keystone Correction

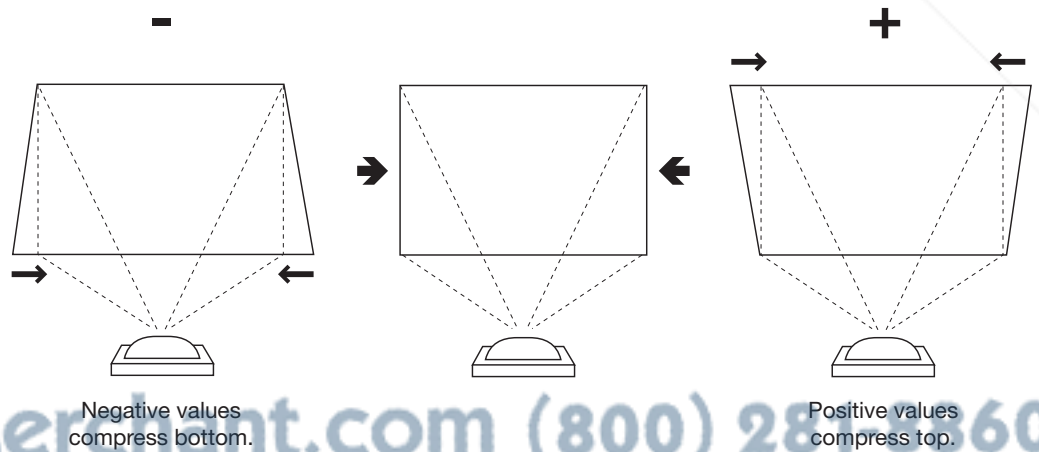

Discount-Merchant.com (800) 281-8860
THE TRUSTED SOURCE FOR PROJECTOR LAMPS AND ACCESSORIES

Figure 4-6. Keystone Correction

- Pincushion:** “Pincushion” distortion can sometimes occur if the throw distance is very short and/or the projector is equipped with an anamorphic lens (refer to **Installing and Adjusting the CineWide Anamorphic Lens** in Section 3). To correct it, select Pincushion from the GeoCorrection menu and use the ◀ or ▶ button to make the image rectangular. See Figure 4-7.

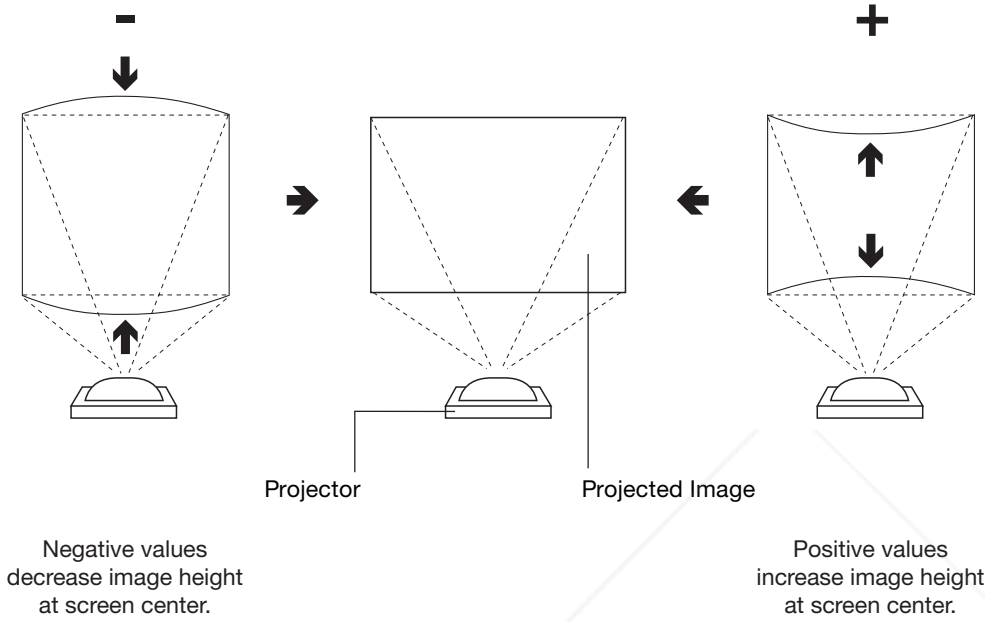

Figure 4-7. Pincushion Correction



Discount-Merchant.com (800) 281-8860
THE TRUSTED SOURCE FOR PROJECTOR LAMPS AND ACCESSORIES

Overscan: Overscan pushes the outside edge of the active picture area of the video signal out beyond the edge of the display area.

Some television programs are produced based on the assumption that older television sets may not display the outer edges of the broadcast picture area. Overscan effectively trims away these inactive, outer edges and enlarges the remaining portion of the image to fill the display area.

Use the on-screen slidebar to select the desired amount of over scan.

For HDTV, DVDs and other video sources, overscan is generally not necessary or desirable.

HD & RGB Adjust: Use the settings in the HD & RGB Adjust menu to fine-tune 480p and higher-resolution signals for optimum picture quality.

- **Auto:** Adjusts the phase, frequency and position automatically.
- **Frequency:** Adjusts the frequency of the signal.
- **Phase:** Adjust the phase if the image (usually from an RGB source) shows shimmer or “noise.” Pixel phase adjusts the phase of the pixel sampling clock relative to the incoming signal. The effect of this control is similar to that of a tracking control on a VCR.

For best results, use a good test pattern such as a smooth gray consisting of a clear pattern of black and white pixels, or a similar “half on, half off” graphic image. (You may find that you can stabilize the image at more than one point. Use either setting in this case.)

- **H. Position:** Adjusts the horizontal position of the image.
- **V. Position:** Adjusts the vertical position of the image.

OSD Setup: Choose OSD Setup from the Installation menu to change the behavior or appearance of the OSD menus.

- **OSD Timer:** Use the ◀ or ▶ button to set the OSD Timer. This timer controls how long the menus remain on-screen after selecting them. Select from 0 to 60 seconds, in 3-second increments. When you set the OSD Timer to 0, the menus remain on-screen until you hide them by pressing **MENU**.
- **OSD Position:** To adjust the horizontal and vertical position of the OSD, press the ▲ or ▼ button to select H. Position or V. Position and use the ◀ or ▶ button to adjust.

Blue Image: Press the ◀ or ▶ button to turn the Blue Image Off or On. This feature removes all red and green color information from the image (simulating a blue filter), and is useful for color-calibrating the projector or other video components.

Sleep Timer: The Sleep Timer automatically puts the projector into standby mode after the amount of time you specify here. (A warning appears on-screen one minute before this is to occur.)

Use the ◀ or ▶ button to set the timer for anywhere from 30 minutes to 6 hours, in 30-minute increments. To disable the Sleep Timer, set it to 0.



Discount-Merchant.com (800) 281-8860
THE TRUSTED SOURCE FOR PROJECTOR LAMPS AND ACCESSORIES

Select Information from the Main Menu to see projector status information: the currently-active source, input signal resolution, aspect ratio, picture memory and lamp usage. This menu also displays the projector serial number.

Should you ever need to contact Runco Technical Support, this information will help them answer your questions or resolve product performance issues.



Tip

You can also press INFO on the VX-3000 remote control unit (Figure 2-4) to display this information.

◀ **Information**

Information	
Source	HDMI 1
Resolution	1920x1080
Aspect Ratio	16:9
Picture Memory	ISF Night
Lamp Hours	450
Serial	RUP900RS0805001

To access advanced projector settings, use the up- or down-arrow keys to highlight Setup and press **ENTER**. Use the number buttons on the remote to enter the Setup menu passcode when prompted and press **ENTER** again. Then, press **MENU** on the remote control.



Note

You only need to enter the Setup menu passcode the first time you select that menu after turning on the projector.

◀ **Setup**

Setup	
Lamp Power	200 Watts
Lamp Hours	>
Fan Mode	Normal
Background Color	Black
PIP	Off
RVR	<input type="text" value="0"/>
12-volt Trigger	Normal
V. Correction	<input type="text" value="0"/>
Amplitude	>
Auto Off	0
Default	

Lamp Power: Select Lamp Power from the Setup Menu to adjust the lamp output level. You can choose to run the lamp as bright as possible (200W; this is the default setting) or you can choose the lower (170W) setting. Generally, lower lamp output prolongs the life of the lamp, but decreases brightness.

Lamp Hours: When you replace the projector lamp (refer to **Lamp Replacement** on page 73), you should also reset the lamp timer. To do this, select Lamp Hours from the Setup menu. Press the right-arrow key on the remote to highlight “Yes,” then press **ENTER** to confirm the reset.



Note

Reset the Lamp Timer ONLY after you replace the lamp. Otherwise, the reported “Lamp Hours” will be inaccurate.



WARNING

Do not exceed the recommended lamp life of 2000 hours. An old lamp becomes increasingly fragile and prone to sudden failure.

Fan Mode: Select Fan Mode from the Setup Menu to control the operation of the projector’s cooling fan.

In most cases, the default Fan Mode (Normal) will maintain the correct operating temperature. If the lamp frequently turns off due to overheating, or in certain high-altitude operating environments, you may need to change this setting to Hi. Altitude or Manual.

To manually set the fan speed, select Manual and press **ENTER**. Then, use the on-screen sidebar to adjust the speed.

Background Color: Press the ◀ or ▶ button to select the image Background Color (black, blue or gray). The Background Color appears when no incoming signal is present.

PIP: To enable or disable the picture-in-picture (PIP) feature, highlight PIP in the Setup menu and press ◀ or ▶ to select On or Off.

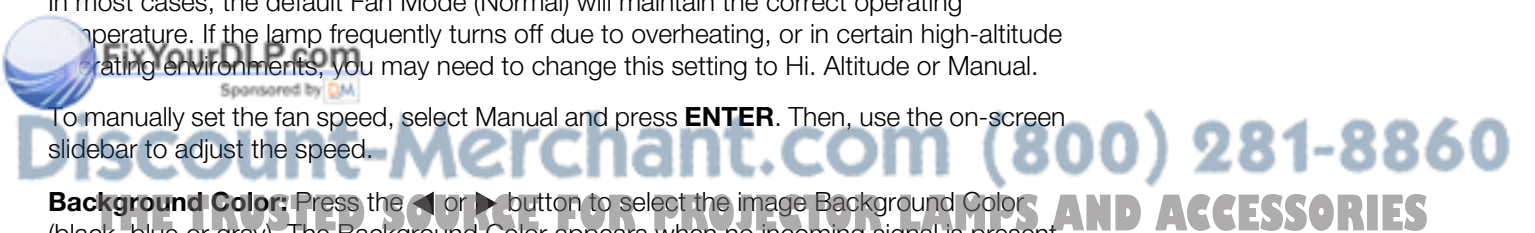

RVR: Use the RVR control to increase or decrease the Reflectance Volume Regulation setting. RVR lets you control the aperture or iris size (the physical opening through the lens; similar to an “f-stop” on a camera). Doing so allows you to optimize brightness and contrast according to the amount of ambient light in the viewing area.

Use a higher setting for rooms with a lot of ambient light. Use a lower setting for more “theater-like” viewing conditions (little or no ambient light).

12-volt Trigger: Select 12-volt Trigger from the Setup menu to configure the 12-volt trigger output.

- Set the 12-volt Trigger to Normal if you want the trigger to activate when the projector is turned on (for instance, if the trigger is controlling a retractable screen).
- Set the 12-volt Trigger to Cinema if you want the trigger to activate when the Cinema or Virtual Cinema aspect ratio is selected. Choose this setting if your VX-3000 is equipped with the Runco CineWide with AutoScope system.

V. Correction: To achieve the proper image geometry with the secondary anamorphic lens, select V. Correction from the Set Up menu. Then, use the ◀ or ▶ button to change the native aspect ratio of the display, in small increments.

Amplitude: The Amplitude menu allows you to fine-tune the aspect ratio by compressing it horizontally or vertically, in small increments. This can be useful if your projector is equipped with an anamorphic lens.

The Horizontal control adjusts the image width while keeping the height constant. Similarly, the Vertical control adjusts the image height while keeping the width constant.

Auto Off: When using the VX-3000 with a computer, use the **Auto Off** feature to have the VX-3000 go into standby mode when no source signal is present on the current input. (A warning message appears on-screen for approximately eight seconds before this occurs.) Select an Auto-Off interval of from five to 30 minutes, in five-minute increments. To return to normal operating mode from the Auto Off standby mode, select the input with the remote control or operate your computer.

When **Auto Off** is disabled, the VX-3000 remains in normal operating mode, regardless of the presence or absence of an input sync signal.



Note

1. If the computer is turned off or not properly connected to the VX-3000, the system is set to the off state.
2. For instructions on using the computer's power management features, refer to the instructions for your computer.

Default: To restore all Setup Menu options to their factory-default values, select Default and press the ▶ button to highlight “Yes.” Then, press **ENTER**.

To access the ISF Calibration menu, select ISF from the Main Menu and press **ENTER**. Use the number buttons on the remote control to enter the ISF Calibration menu passcode when prompted and press **ENTER** again. Then, press **MENU** on the remote control.

◀ ISF

ISF	
Picture Memory	ISF Night
Copy Settings	>
Brightness	50
Contrast	50
Color	50
Tint	0
Sharpness	5
Color Temperature	6500
White Balance	>
Advanced Options	>
Reset to Defaults	



Note

This menu should be used by ISF-certified technicians only.

Picture Memory/Copy Settings: These settings are described in the **Picture Adjust** section (page 56).



Note

The Picture Memory selection you make here is retained when the projector is powered off, then on again.

Brightness/Contrast/Color/Tint/Sharpness/Color Temperature: These settings are described in the **Picture Adjust** section (refer to page 56).

White Balance: To remove any trace of color from the white areas of the projected image, select the “Custom 1” or “Custom 2” Color Temperature. Then, choose White Balance from the ISF menu and press **ENTER**.

- **Gain:** Use the Gain controls to correct color imbalances in the bright areas of the image. A good way to do this is to use a test pattern consisting mostly of solid white areas, such as an 80 IRE “window” pattern. If the white areas contain traces of red, green or blue, decrease the Gain for that color.
- **Offset:** Use the Offset controls in the White Balance sub-menu to correct color imbalances in the dark areas of the image. A good way to do this is to use a test pattern consisting mostly of dark gray areas, such as a 30 IRE “window” pattern. If the gray areas contain traces of red, green or blue, decrease the Offset for that color.

The Gain controls increase or decrease the full-scale input range; the Offset controls shift the entire range, resulting in a change in brightness. Figure 4-8 shows how the Gain and Offset controls interact with each other.

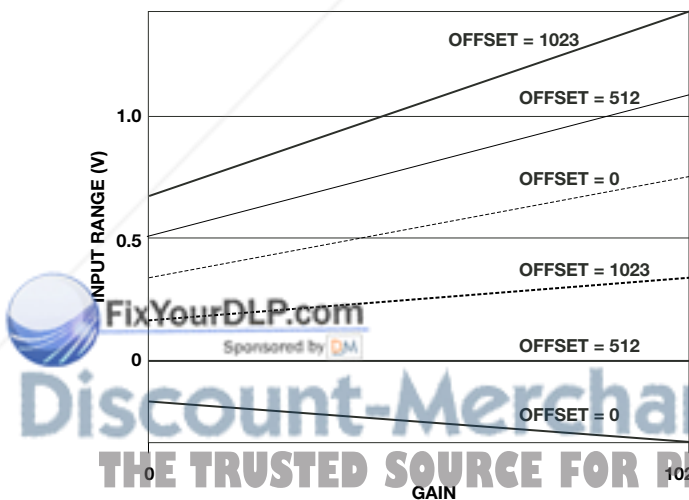

Figure 4-8. Gain and Offset

**Note**

Generally, higher Gain settings reduce the image contrast; higher Offset settings reduce the image brightness.

Advanced Options: For more precise control over picture quality, select Advanced Options from the ISF menu and press **ENTER**.

- **Image Enhance:** The Image Enhance menu gives you options for improving the quality of standard-definition, 480i images. (For 480p and higher-definition images, the controls in this menu are disabled.) Keep in mind that these controls add frequencies that are not present in the original signal, and may make images appear “noisy” if misused.
 - **DNR:** Use the ◀ or ▶ button to adjust the Digital Noise Reduction (DNR). DNR is useful for clearing up noisy images from interlaced SD sources. Adjust as desired, keeping in mind that reducing noise (which reduces high frequencies) may also soften the image.
 - **Detail Enhance:** Use the Detail Enhance control to improve the apparent horizontal and/or vertical resolution of the image.
 - **Luma Enhance:** Use the Luma Enhance control to improve the apparent brightness of the image.
 - **Chroma Enhance:** This control adds chroma (color information) to the input signal and can make colors appear more vibrant and saturated.
- **Black Threshold:** This control compensates for incoming elevated black levels present in certain video signals, and ensures that blacks in the display are neither “crushed” (where dark grays appear black) nor excessively elevated (where blacks appear dark gray). By default, the projector automatically determines the best setting according to the type of incoming video signal:
 - **0 IRE:** Used for DVD output with “enhanced black,” SECAM, most PAL standards and Japanese NTSC.
 - **7.5 IRE:** Used for most NTSC video signals.

For some types of video, you may want to override the setting. Generally, if black appears crushed when brightness = 30, choose “0 IRE.” If black appears excessively elevated, use “7.5 IRE.”

- **Gamma Selection:** The normal gamma setting of 2.2 is correct for almost all signals and conditions. If excess ambient light washes out the image and it becomes difficult or impossible to see details in dark areas, lower the gamma setting to compensate. This will improve contrast while maintaining good details for blacks. Conversely, if the image is washed out and unnatural, with excessive detail in black areas, increase the setting. Again, good gamma improves contrast while maintaining good details for blacks and whites.



Discount-Merchant.com (800) 281-8860
THE TRUSTED SOURCE FOR PROJECTOR LAMPS AND ACCESSORIES

- **Advanced Color Enhance (ACE):** Use the Advanced Color Enhance (ACE) controls to customize the stored color space characteristics. To do this, use the ◀ or ▶ button to select a component color (Red, Green, Blue, Yellow, Cyan or Magenta).

For each component color, you can adjust the following:

- **Limit:** This sidebar adjusts the intensity – also known as *luminance* – of a given color.
- **Saturation:** This sidebar adjusts the color saturation level – the amount of that color in a video image. Lower settings produce less saturated colors; a setting of “0” removes that color from the image entirely. If the saturation is too high, that color will be overpowering and unrealistic.

To restore the color space settings to their factory-default values, select Reset to Defaults and press **ENTER**.

- **Gamut:** Under most conditions, the White Balance and Advanced Color Enhance (ACE) controls in the Calibration menu are adequate for producing accurate and realistic colors from a variety of sources.

In rare cases, though, you may need more precise control over the VX-3000 display color gamut (range). For example, you may require a unique color gamut for a given projector or application.

The VX-3000 enables you to define the precise hue of each primary color component (white, red, green and blue) used to generate the millions of colors produced in displays. You do this by specifying x/y coordinates and luminance values for each primary color component.

The x and y coordinates for each color define its location on the standard CIE chromaticity graph, shown in Figure 4-9. (CIE stands for “Commission Internationale de l’Éclairage” (International Commission on Illumination), the organization responsible for color measurement and management standards.)

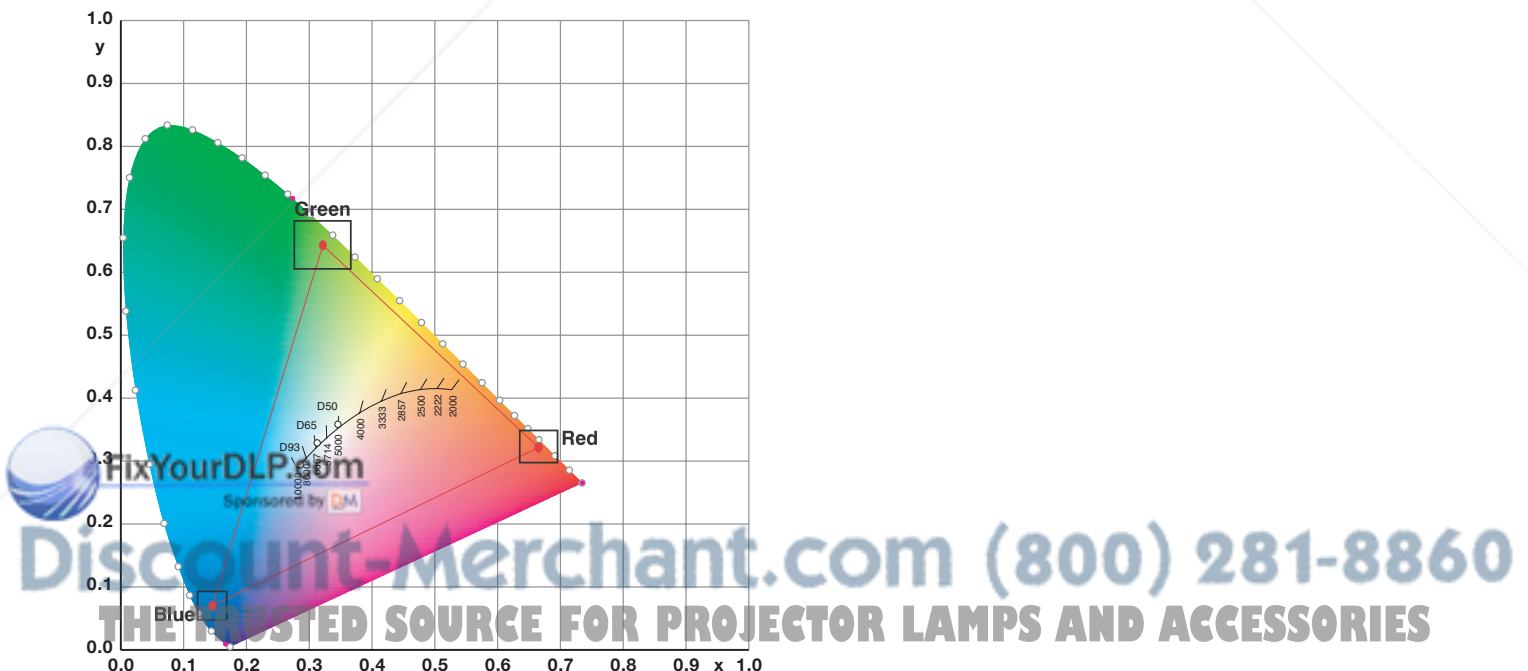

Figure 4-9. CIE 1931 Chromaticity Diagram

Changing either or both of these numbers changes the hue of the color and relocates the “triangle” for possible colors. For example, changing the x/y coordinates for red moves the color closer to either orange or violet, which in turn affects all displayed colors having a red component.



Note

To perform these adjustments, you will need a color analyzer (Sencore ColorPro 5000 software and ColorPro III sensor, or equivalent).

To adjust the gamut:

Gamut			
Settings	Manual		
White	x:312	y:329	Y:045
Red	x:640	y:330	Y:015
Green	x:300	y:600	Y:022
Blue	x:150	y:060	Y:018
D. White	x:312	y:329	Y:045
Enter			
Save			
Color Temp.	6500		

White	x:000	y:000	Y: 000
-------	-------	-------	--------

1. Select Gamut from the Advanced Options menu and press **ENTER**.
2. To do an automatic gamut adjustment, highlight “Enter” and press **ENTER**. If further calibration is necessary, continue with the next step.
3. Highlight “Settings” and press ◀ or ▶ to select “Manual.”
4. Highlight “White” and press **ENTER**. The VX-3000 displays a white field on the screen.
5. Using the color analyzer, measure the x and y coordinates for about 15 seconds. Make a note of the results.
6. Press **EXIT** or **ENTER**.
7. Highlight “White” and press ▶.
8. Press **ENTER** to select the first digit of the x coordinate value for White (obtained in Step 5).
9. Press ▲ or ▼ repeatedly to set the digit.
10. Press ▶ to select the next digit; use the ▲ and ▼ buttons to change it.
11. Repeat Step 10 for the third digit.
12. Press **ENTER**.
13. Press ▶ to highlight the “y” coordinate value for White. Then, press **ENTER** to select the first digit.
14. Repeat Steps 9 through 12 to set the “y” coordinate value for White.
15. Press ▶ to highlight the “Y” coordinate value. Then press **ENTER** to select the first digit.
16. Repeat Steps 9 through 12 to set the “Y” coordinate value for White.
17. Press **EXIT**.
18. Repeat Steps 4 through 17 for Red, Green, Blue and D. White (Desired White).
19. Highlight “Save” and press **ENTER**.

To undo the effects of a previous calibration, highlight “Settings” and press ◀ or ▶ to select “Default.”

Reset to Defaults: To restore the ISF default image settings for the current input source ONLY, select Reset to Defaults and press the ▶ button to highlight “Yes.” Then, press **ENTER**.

5. Maintenance and Troubleshooting

The lamp should be replaced when it reaches the end of its life (typically 2000 hours), or sooner if a noticeable degradation in brightness occurs. Contact your Runco dealer to obtain a replacement lamp.

5.1 Lamp Replacement

1. Turn off the projector and unplug the power cord.
Allow the projector to cool down for approximately 45 minutes prior to removing the lamp assembly for replacement.

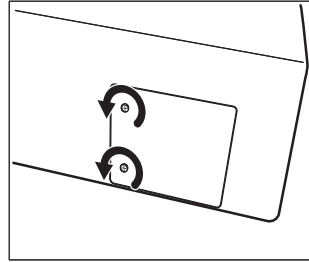

2. Loosen the two captive screws from the lamp cover.

3. Remove the lamp cover.

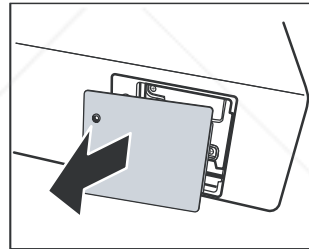

4. Remove the two lamp assembly mounting screws.

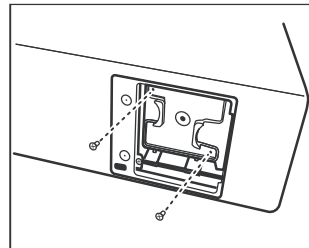

5. Grasp the lamp assembly handle and pull gently, removing the lamp module from the projector housing.
6. Install the new lamp module and replace the two screws.

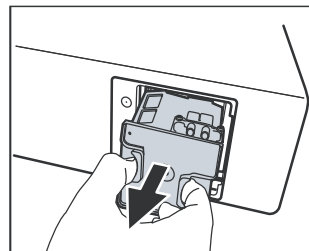

Replace the lamp cover at the right side first and secure it with the two screws.

8. Turn on the power and select Lamp Hours from the Setup menu to reset the lamp timer (refer to **Lamp Hours** on page 67).

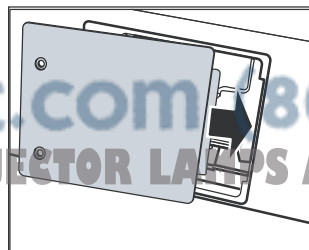

5.2 Troubleshooting Tips

Table 5-1 provides some general guidelines for troubleshooting problems you may encounter with the VX-3000. If the suggested solutions fail to resolve the problem or if you encounter an issue not described here, please contact Runco Technical Support.

Table 5-1. Troubleshooting Chart

Symptom	Possible Cause(s)	Solution
The projector does not turn on.	<ul style="list-style-type: none"> The VX-3000 is not plugged in or the AC outlet is not active. The main power switch (at the rear of the projector) is off. Lamp cover is not securely attached. 	<ul style="list-style-type: none"> Ensure that the VX-3000 is plugged in and that the AC outlet is active. Turn on the power switch. Securely attach the lamp cover.
The projector does not turn back on after it was powered off.	<ul style="list-style-type: none"> The projector will not turn on for two minutes after power-off, to protect the lamp. 	<ul style="list-style-type: none"> Wait until the VX-3000 completes its cool-down (POWER LED lights solid orange).
The remote control does not work correctly.	<ul style="list-style-type: none"> The batteries have run out. 	<ul style="list-style-type: none"> Replace the batteries.
The projector is on and OSD menus appear, but there is no video image on-screen.	<ul style="list-style-type: none"> Incorrect source selection. Source component is not turned on. Source component is connected incorrectly or not at all. 	<ul style="list-style-type: none"> Select the correct source. Turn on the source. Check cable connection from source component to projector.
A projected image from a DVD is split or otherwise scrambled.	<ul style="list-style-type: none"> DVD player is connected to the Component input and set to progressive scan mode. 	<ul style="list-style-type: none"> Turn off progressive scan on the DVD player.
Image is blurred.	<ul style="list-style-type: none"> The lens is not correctly focused. 	<ul style="list-style-type: none"> Adjust the focus with the remote control.
Image is too bright and/or lacks definition in the bright areas of the image.	<ul style="list-style-type: none"> Contrast is set too high. 	<ul style="list-style-type: none"> Lower the contrast setting.
Image appears "washed out" and/or dark areas appear too bright.	<ul style="list-style-type: none"> Brightness is set too high. 	<ul style="list-style-type: none"> Lower the brightness setting.
Colors in the image are swapped; for example, reds appear blue or vice versa.	<ul style="list-style-type: none"> The Red/Pr, Green/Y or Blue/Pb outputs from the source are connected to the wrong inputs on the VX-3000. 	<ul style="list-style-type: none"> Ensure that the source outputs are connected to the correct VX-3000 input.
POWER LED lights solid red.	<ul style="list-style-type: none"> Internal failure. 	<ul style="list-style-type: none"> Please contact your Runco dealer for assistance.



Discount-Merchant.com (800) 281-8860
 THE TRUSTED SOURCE FOR PROJECTOR LAMPS AND ACCESSORIES

Table 5-1. Troubleshooting Chart (continued)

Symptom	Possible Cause(s)	Solution
LAMP LED lights solid red.	<ul style="list-style-type: none"> The lamp has failed or exceeded its usage life. 	<ul style="list-style-type: none"> Replace the lamp with a new one.
TEMP LED lights solid red.	<ul style="list-style-type: none"> VX-3000 internal temperature is too high or one or more fans have failed. 	<ul style="list-style-type: none"> Power off the VX-3000 and allow it to cool down. Ensure that the intake and exhaust vents are not blocked. Turn the projector back on. If the problem persists, please contact your Runco dealer for assistance.



Discount-Merchant.com (800) 281-8860
THE TRUSTED SOURCE FOR PROJECTOR LAMPS AND ACCESSORIES

Notes:



Discount-Merchant.com (800) 281-8860
THE TRUSTED SOURCE FOR PROJECTOR LAMPS AND ACCESSORIES

6. Serial Communications

To interface the VX-3000 with a home theater automation/control system or a PC running terminal emulation software:

1. Connect it to your control system or PC as shown in Figure 3-17.
2. Start a terminal session on your PC using a terminal-emulation program, such as HyperTerminal.
3. Configure the RS-232 controller or PC serial port as follows: no parity, 8 data bits, 1 stop bit and no flow control. Set the baud rate to 19200.
4. Type a command from among those listed in Table 6-1. For example, to select the Component 1 input, type `x133x`. **Do not send a carriage return after the command.**

Serial commands to the VX-3000 take the following form:

- Commands are in ASCII format.
- Commands must be in UPPERCASE; for example, `X001X`, **not** `x001x`.
- When you send a valid command, the VX-3000 performs the following actions:
 1. Echoes the command back to the PC or control system, unless the command is `x001x` (Power On).
 2. Executes the command.
 3. Sends a confirmation message in the form `X0_[command number]X<CR>`. The confirmation message does not include the leading zeros in the command.

For example, when you send the command `x003x`, the VX-3000 responds with `X003XX0_3X<CR>`. When you send the command `x061x`, the VX-3000 responds with `X061XX0_61X<CR>`. When you send the command `x133x`, the VX-3000 responds with `X133XX0_133X<CR>`.

- When you enter an invalid command, the VX-3000 echoes the command and does nothing else.

6.1 RS-232 Connection and Port Configuration

6.2 Serial Command Syntax



Note

The VX-3000 will not accept serial commands for 20 seconds after it is turned on or off.

Table 6-1. Serial Commands: X Command (Write Only)

Code	Function
<code>X006, X014, X000, X003, X000, X034, X011, X000, X05c</code>	Power on
<code>X001X</code>	Serial command test action
<code>X002X</code>	Power off

Table 6-1. Serial Commands: X Command (Write Only) (continued)

Code	Function
X003X	Menu
X004X	Enter
X005X	Exit
X006X	Up
X007X	Down
X008X	Left
X009X	Right
X011X	Info
X021X	Remote 1
X022X	Remote 2
X023X	Remote 3
X024X	Remote 4
X025X	Remote 5
X026X	Remote 6
X027X	Remote 7
X028X	Remote 8
X029X	Remote 9
X030X	Remote 0
X041X	Picture Memory "Custom 1"
X042X	Picture Memory "Custom 2"
X043X	Picture Memory "ISF Day"
X044X	Picture Memory "ISF Night"
X047X	Picture Adjust Reset to default
X048X	Setup Reset to default
X049X	ISF Reset to Default
X050X	show serial number
X051X	load gamma 2.2
X052X	remove all msg
X053X	copy comp1 color temperature value to comp2, RGBHD, HDMI1, HDMI2 copy video color temperature value to svideo.
X054X	copy 6500 to CT1 and CT2

Table 6-1. Serial Commands: X Command (Write Only) (continued)

Code	Function
X055X	open pip window
X056X	PIP increase sub window size
X057X	PIP decrease sub window size
X058X	Set PIP active window
X059X	Set PIP on
X060X	Set PIP off
X061X	Aspect Ratio:16:9
X062X	Aspect Ratio:4:3
X063X	Aspect Ratio:LetterBox
X064X	Aspect Ratio:VirtualWide
X065X	Aspect Ratio:Cinema
X066X	Aspect Ratio:VirtualCinema
X067X	For service tool copy ct RGB value
X071X	baud rate = 9600
X072X	baud rate = 19200
X073X	baud rate = 115200(default)
X081X	show factory menu
X082X	Image orientation:floor front
X083X	Image orientation:ceiling front
X084X	Image orientation:floor rear
X085X	Image orientation:ceiling rear
X091X	Lamp ECO Mode
X092X	Lamp Normal Mode
X093X	disable auto source searching
X095X	enable printf
X096X	disable printf
X100X	0 IRE
X101X	7.5 IRE
X102X	print fan rpm
X103X	print adc values

Table 6-1. Serial Commands: X Command (Write Only) (continued)

Code	Function
X106X	copy comp 720P ADC value to other timing
X107X	copy comp 721P ADC value to other timing(7.5 IRE)
X108X	copy RGBHD ADC value to other timing
X109X	copy 5160 video ntsc value to pal
X110X	copy 5160 svideo ntsc value to pal
X112X	Color Temp: 5400
X113X	Color Temp: 6500
X114X	Color Temp: 9300
X115X	Color Temp: Custom1
X116X	Color Temp: Custom2
X121X	Switch OSD language 1 English
X122X	Switch OSD language 2 French
X123X	Switch OSD language 3 Spanish
X124X	Switch OSD language 4 German
X125X	Switch OSD language 5 Italian
X131X	CVBS
X132X	S-Video
X133X	Comp1
X134X	Comp2
X135X	HDMI1
X136X	HDMI2
X137X	RGBHD
X151X	reset user lamp timer
X152X	reset factory lamp timer
X156X	Background Color = Black
X157X	Background Color = Blue
X158X	BackGround Color = Gray 60
X175X	Burn-In mode off
X180X	Blue Image ON
X181X	Blue Image OFF

Table 6-1. Serial Commands: X Command (Write Only) (continued)

Code	Function
X182X	Burn-In on/off eco
X183X	Burn-In on/off normal
X221X	32-Gray bars
X226X	Checker board
X231X	DMDRedCurtain
X232X	DMDGreenCurtain
X233X	DMDBlueCurtain
X234X	DMDFullBlackCurtain
X235X	DMDYellowSolidField
X236X	DMDCyanSolidField
X237X	DMDMagentaSolidField
X252X	DMDFullWhiteCurtain
X253X	set IRIS full off
X254X	set IRIS full on
X255X	set dynamic black off
X256X	set dynamic black on
X260X	test pattern off
X300X	focus enable
X301X	focus disable
X302X	zoom enable
X303X	zoom disable
X333X	switch events
X400X	show resolution
X500X	Set Gamma 2.8
X501X	Set Gamma 2.5
X502X	Set Gamma 2.2
X503X	Set Gamma 1.0
X504X	Set Gamma 2.4
X505X	Set Gamma 2.6
X520X	Focus increment (+1)

Table 6-1. Serial Commands: X Command (Write Only) (continued)

Code	Function
X521X	Focus decrement (-1)
X522X	Zoom increment (+1)
X523X	Zoom decrement (-1)
X524X	RVR increment (+1)
X525X	RVR decrement (-1)
X526X	H Lens Shift increment (+1)
X527X	H Lens Shift decrement (-1)
X528X	V Lens Shift increment (+1)
X529X	V Lens Shift decrement (-1)
X530X	H keystone increment (+1)
X531X	H keystone decrement (-1)
X532X	V keystone increment (+1)
X533X	V keystone decrement (-1)
X550X	Disable Splash screen
X551X	Enable splash screen
X552X	Disable OSD message
X553X	Enable OSD message
X570X	Read total lamp hours
X900X	reset IRIS position
X901X	get power status
X902X	projector states
X996X	show composer version
X997X	Show firmware version
X998X	show mcu version
X999X	show iris version

Table 6-2. Serial Commands: Z Command

Code	Function
Z001	Lamp hours -- Normal (User OSD)
Z002	Lamp hours -- ECO (User OSD)
Z004	Lamp hours -- Normal (Factory OSD)
Z005	Lamp hours -- ECO (Factory OSD)
Z010	picture mode setting
Z011	User brightness
Z012	User contrast
Z014	User color
Z015	User tint
Z016	User sharpness
Z017	Color temperature
Z034	Burn-In On timer
Z035	Burn-In Off timer
Z038	Burn-In Cycle
Z090	select IRE
Z091	NR_TR
Z092	Detail Enhance
Z093	LTI
Z094	CTI
Z104	Gamma gain -- Red (adjust ColorTemp)
Z105	Gamma gain -- Green(adjust ColorTemp)
Z106	Gamma gain -- Blue(adjust ColorTemp)
Z107	Gamma offset -- Red(adjust ColorTemp)
Z108	Gamma offset -- Green(adjust ColorTemp)
Z109	Gamma offset -- Blue(adjust ColorTemp)
Z127	DLP Color Wheel delay
Z128	DLP Degamma Table
Z129	system works timer
Z131	R offset to RGBHD(AD9984)
Z132	G offset to RGBHD(AD9984)
Z133	B offset to RGBHD(AD9984)

Table 6-2. Serial Commands: Z Command (continued)

Code	Function
Z134	R gain to RGBHD(AD9984)
Z135	G gain to RGBHD(AD9984)
Z136	B gain to RGBHD(AD9984)
Z137	Y offset to Comp(AD9984)
Z138	Pb offset to Comp(AD9984)
Z139	Pr offset to Comp(AD9984)
Z140	Y offset to Comp(AD9984)
Z141	Pb offset to Comp(AD9984)
Z142	Pr offset to Comp(AD9984)
Z143	HDMI1 color space
Z144	HDMI2 color space
Z145	Splash timer
Z146	Cine Wide mode
Z147	Splash Screen ISF or normal
Z148	Focus Zoom OSD visible
Z150	select RS232 baudrate
Z151	Dep Timing
Z152	Change Timing Tmp
Z153	RGBHD ADC R offset
Z154	RGBHD ADC G offset
Z155	RGBHD ADC B offset
Z156	RGBHD ADC R gain
Z157	RGBHD ADC G gain
Z158	RGBHD ADC B gain
Z163	comp2 720p ADC R offset
Z164	comp2 720p ADC G offset
Z165	comp2 720p ADC B offset
Z166	comp2 720p ADC R gain
Z167	comp2 720p ADC G gain
Z168	comp2 720p ADC B gain
Z173	comp2 1080p ADC R offset
Z174	comp2 1080p ADC G offset

Table 6-2. Serial Commands: Z Command (continued)

Code	Function
Z175	comp2 1080p ADC B offset
Z176	comp2 1080p ADC R gain
Z177	comp2 1080p ADC G gain
Z178	comp2 1080p ADC B gain
Z180	Red range
Z181	Green range
Z182	Blue range
Z183	Yellow range
Z184	Cyan range
Z185	Magenta range
Z186	Red saturation
Z187	Green saturation
Z188	Blue saturation
Z189	Yellow saturation
Z190	Cyan saturation
Z191	Magenta saturation
Z200	Gamut menu

Table 6-3. Serial Commands: U Command

Code	Function
U1	Set ISF Name (1th~10th word)
U2	Set ISF Name (11th~20th word)
U3	Set ISF Name (21th~30th word)
U4	Set ISF Name (31th~40th word)
U5	Set ISF Name (41th~50th word)
U6	Set ISF Name (51th~60th word)
U7	Set ISF Name (61th~70th word)
U8	Set ISF Name (71th~80th word)

 FixYourDLP.com
 Discount-Merchant.com (800) 281-8860
 THE TRUSTED SOURCE FOR PROJECTOR LAMPS AND ACCESSORIES



Discount-Merchant.com (800) 281-8860
THE TRUSTED SOURCE FOR PROJECTOR LAMPS AND ACCESSORIES

7. Specifications

Table 7-1 lists the VX-3000 specifications.

Table 7-1. VX-3000 Specifications

Projector Type:	Digital Light Processing (DLP), Single-Chip SuperOnyx DMD
Native Resolution:	1920 x 1080 (16:9)
Aspect Ratios:	4:3, Letterbox, 16:9, VirtualWide, Cinema, Virtual Cinema
Video Standards:	NTSC, PAL, ATSC
Video Compatibility:	480i, 480p, 576i, 576p, 720p, 1080i, 1080p
Scan Frequency:	Horizontal: 15 - 80 kHz Vertical: 50 - 100 Hz
Picture Size (16:9 Screen):	Recommended Width: 72 in. (1.83 m) to 96 in. (2.44 m)
Throw Distance (Factor x Screen Width):	Refer to Table 3-3
Vertical Offset (when projector is inverted):	Refer to Table 3-4
Horizontal Offset:	Refer to Table 3-4

7.1 VX-3000 Specifications



Discount-Merchant.com (800) 281-8860
THE TRUSTED SOURCE FOR PROJECTOR LAMPS AND ACCESSORIES

Table 7-1. VX-3000 Specifications (continued)

Brightness and Contrast:	<p>Cinema Standards Measurement System (CSMS) Specifications – VX-3000i/VX-3000d</p> <ul style="list-style-type: none"> - Brightness*: 13.9 to 19.8 foot-Lamberts (fL) - Contrast Ratio*: 196:1 to 206:1 <p>Cinema Standards Measurement System (CSMS) Specifications – VX-3000 Ultra Series</p> <ul style="list-style-type: none"> - Brightness*: 15.5 to 18.0 foot-Lamberts (fL) - Contrast Ratio*: 156:1 to 190:1 <p>*Variable depending on RVR setting</p> <p>These measurements are taken from the projector in a controlled, home theater environment. All measurements are made to ANSI/NAPM IT7.228-1997 specifications using the Photo Research PR-650 SpectraColorimeter and Minolta LS-100 Luminance Meter, Video Essentials test DVD and a 1.3 gain, 72-inch wide screen. The projector is calibrated to a color temperature of 6,500K and has a minimum of 150 hours of usage.</p> <p>The foot-Lambert (fL) is the unit of measurement used in commercial movie theaters to express image brightness at the screen surface. The Society of Motion Picture and Television Engineers (SMPTE) specifies 16 fL as the target image brightness for film-based projectors using an open gate (without film in the projector). More importantly, today SMPTE specifies 12 fL as the target image brightness in Digital Cinema theaters. The foot-Lambert measurement is dependent on screen size, screen gain and projector light output.</p> <p>Home Theater Calibration Specifications – VX-3000i/VX-3000d</p> <ul style="list-style-type: none"> - Light Output: 438 to 543 ANSI Lumens - Contrast Ratio*: 196:1 to 206:1 <p>Home Theater Calibration Specifications – VX-3000 Ultra Series</p> <ul style="list-style-type: none"> - Light Output: 368 to 443 ANSI Lumens - Contrast Ratio*: 156:1 to 190:1 <p>These specifications are obtained by calibrating the projector as described above for CSMS measurements.</p> <p>Industry-Standard Specifications – VX-3000i/VX-3000d</p> <ul style="list-style-type: none"> - Light Output: 800 ANSI Lumens - Contrast Ratio: 3000:1 <p>Industry-Standard Specifications – VX-3000 Ultra Series</p> <ul style="list-style-type: none"> - Light Output: 1000 to 1250 ANSI Lumens - Contrast Ratio: 1200:1 to 1400:1 typical (sequential) <p>These are typical projector brightness and contrast specifications found in most companies' sales literature. Runco includes these measurements in its literature to allow for direct comparison with other manufacturers' projectors. These measurements are typically taken at 9,000K to 13,000K to get expected performance data when the projector is used in professional, commercial and industrial displays.</p>
Lamp:	200 Watts
Estimated Lamp Life:	2000 hours
Video Inputs:	(1) Composite Video, (1) S-Video, (1) RGB/Component Video (5 x BNC), (1) RCA Component Video (3 x RCA), (2) HDMI
Control Options:	<ul style="list-style-type: none"> - Discrete IR remote - Serial commands via RS-232
RS-232 Communication Parameters:	19200 bps, no parity, 8 data bits, 1 stop bit, no flow control



Discount-Merchant.com (800) 281-8860
THE TRUSTED SOURCE FOR PROJECTOR LAMPS AND ACCESSORIES

Table 7-1. VX-3000 Specifications (continued)

+12V Output:	Max. 0.25 Amps, active when Cinema or Virtual Cinema Aspect Ratio is selected (CineWide versions only) or when projector is turned on; Tip = +12V; Sleeve = Ground
Power Requirements:	100 to 240 VAC (auto-sensing), 50/60 Hz, 290 Watts (989.8 BTUs/hour)
Operating Environment:	41°F to 95°F (5°C to 35°C), 20% to 80% humidity (non-condensing)
Dimensions:	VX-3000i/VX-3000d: See Figure 7-1 VX-3000 Ultra: See Figure 7-2 VX-3000/CineWide with AutoScope: See Figure 7-3
Weight (without lens):	34 lbs. (15.42 kg)
Regulatory Approvals:	Complies with FCC Class B, CE, CB, cTUV-US
Limited Warranty:	Projector: Two (2) years parts and labor from the date of delivery to the end user. Lamp: 1000 hours or six (6) months, whichever comes first.

Specifications are subject to change without notice.



Discount-Merchant.com (800) 281-8860
THE TRUSTED SOURCE FOR PROJECTOR LAMPS AND ACCESSORIES

**7.2
Overall Dimensions –
VX-3000i/CineWide
and
VX-3000d/CineWide**

Figure 7-1 shows the VX-3000 dimensions (all dimensions are in inches).

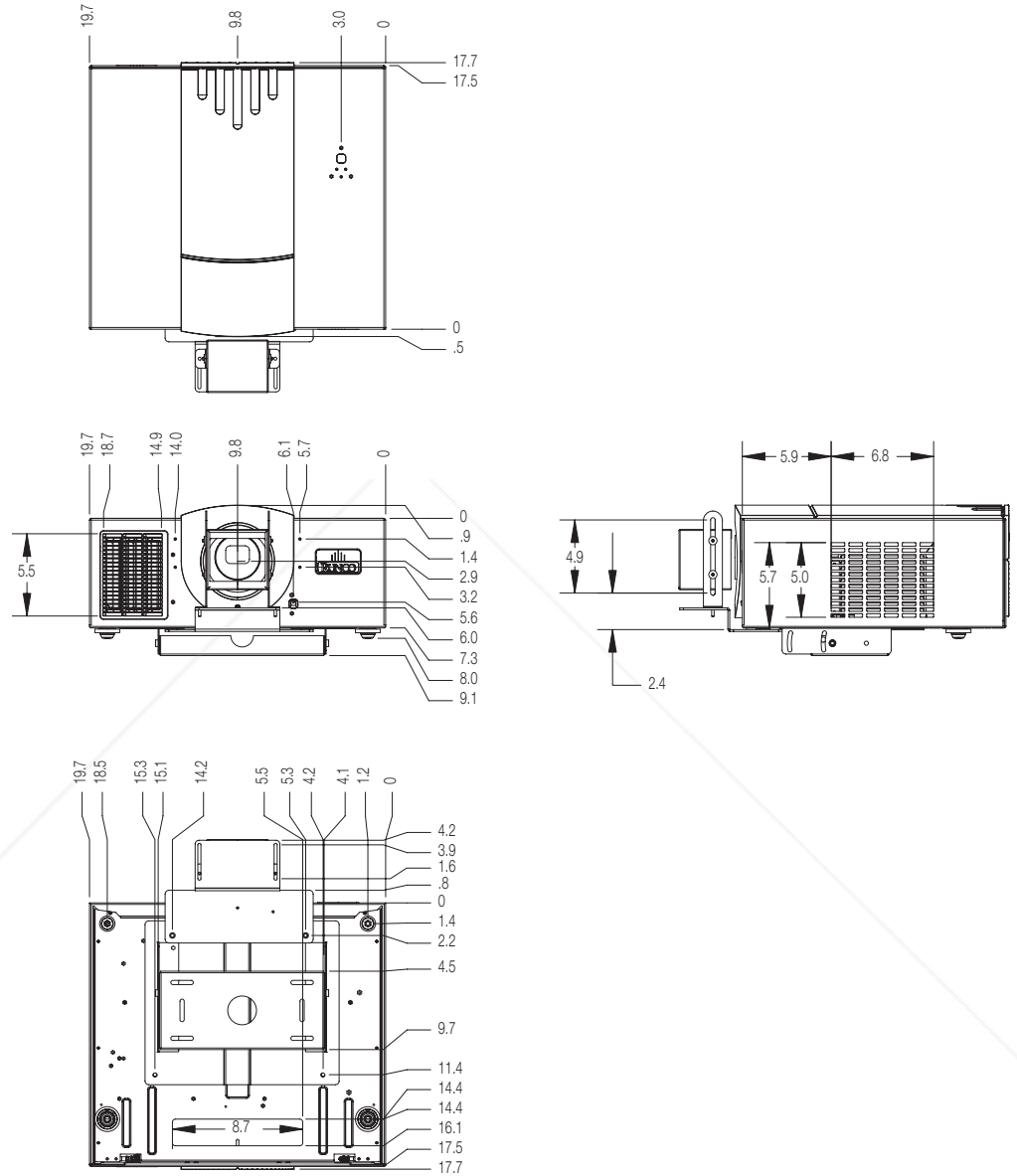

Figure 7-1. Overall Dimensions – VX-3000i/CineWide and VX-3000d/CineWide (Prismatic Lens)



Discount-Merchant.com (800) 281-8860
THE TRUSTED SOURCE FOR PROJECTOR LAMPS AND ACCESSORIES

Figure 7-2 shows the VX-3000 Ultra dimensions (all dimensions are in inches).

7.3 Overall Dimensions - VX-3000 Ultra

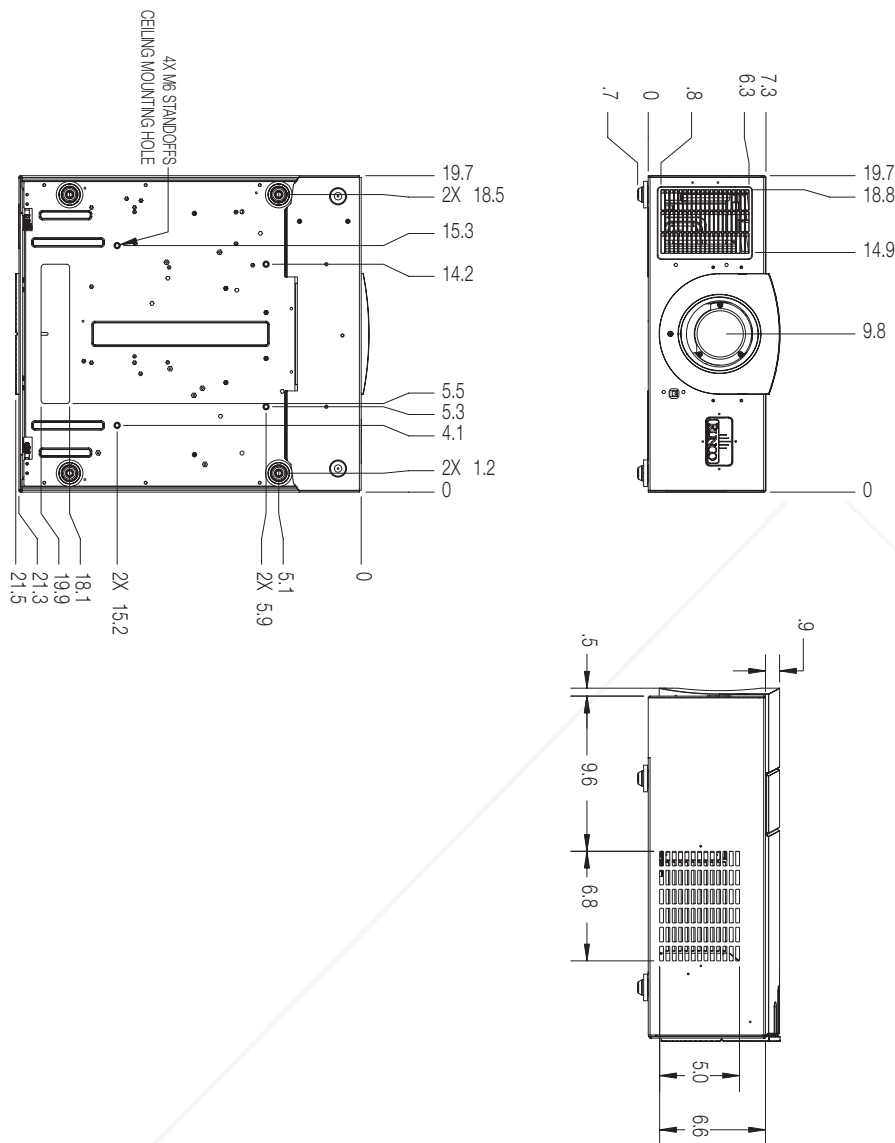

Figure 7-2. Overall Dimensions – VX-3000 Ultra



Discount-Merchant.com (800) 281-8860
THE TRUSTED SOURCE FOR PROJECTOR LAMPS AND ACCESSORIES

7.4 Overall Dimensions – VX-3000i/CineWide with AutoScope and VX-3000d/CineWide with AutoScope

Figure 7-3 shows the VX-3000/CineWide with AutoScope dimensions (all dimensions are in inches).

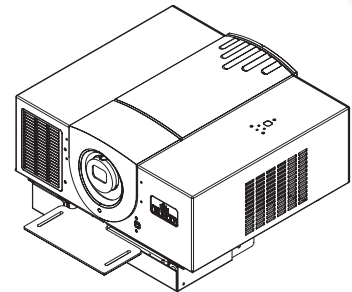
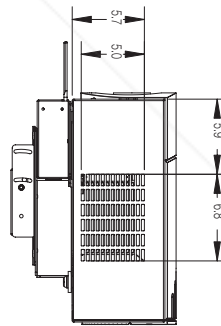
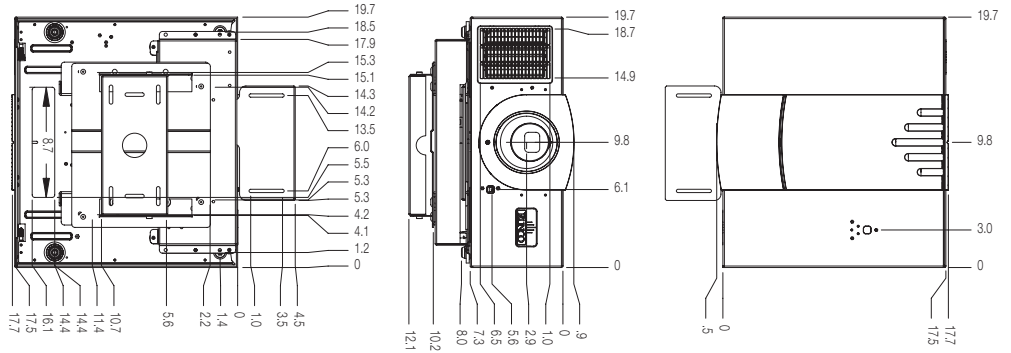

Figure 7-3. Overall Dimensions – VX-3000i/CineWide with AutoScope



Discount-Merchant.com (800) 281-8860
THE TRUSTED SOURCE FOR PROJECTOR LAMPS AND ACCESSORIES

Table 7-2 lists the signal types supported by each input on the VX-3000.

Table 7-2. Supported Signal Timings

Format	Resolution	Refresh Rate (Hz)	Horizontal Frequency (kHz)	Pixel Frequency (MHz)
Analog/Digital PC Signals (RGB HD / HDMI 1 / HDMI 2)				
720x350	720x350	70.00	31.469	28.322
720x400	720x400	70.00	31.469	28.322
		85.00	37.900	35.500
640x480	640x480	60.00	31.469	25.175
		72.00	37.861	31.500
		75.00	37.500	31.500
		85.00	43.269	36.000
800x600	800x600	56.00	35.156	36.000
		60.00	37.879	40.000
		72.00	48.077	50.000
		75.00	46.875	49.500
		85.00	53.674	56.250
848x480	848x480	60.00	31.02	33.750
1024x768	1024x768	60.00	48.363	65.000
		70.00	56.476	75.000
		75.00	60.023	78.750
		85.00	68.677	94.500
1152x864	1152x864	75.00	67.500	108.000
1280x768	1280x768	60.00	47.396	68.250
		60.00	47.776	79.500
		75.00	60.289	102.250
		85.00	68.633	117.500
1280x960	1280x960	60.00	60.000	108.000
		85.00	85.938	148.500
1280x1024	1280x1024	60.00	63.981	108.000
		75.00	79.976	135.000
		85.00	91.146	157.500
1360x768	1360x768	60.00	47.712	85.500

7.5

Supported Timings

Table 7-2. Supported Signal Timings (continued)

Format	Resolution	Refresh Rate (Hz)	Horizontal Frequency (kHz)	Pixel Frequency (MHz)
1400x1050	1400x1050	60.00	64.744	101.000
		60.00	65.317	121.750
		75.00	82.278	156.000
1440x900	1440x900	60.00	55.469	88.750
		60.00	59.935	106.500
		75.00	70.635	136.750
		85.00	80.430	157.000
1600x1200	1600x1200	60.00	75.000	162.000
1680x1050	1680x1050	60.00	64.674	119.000
		60.00	65.290	146.250
1920x1200	1920x1200	60.00	74.038	154.000
EDTV/HDTV Signals (HDMI 1 / HDMI 2 / Component 1 (YPbPr) / Component 2 (YPbPr or RGB))				
480/60i	720x487	59.94	15.734	13.500
480/60p	720x483	59.94	31.469	27.000
576/50i	720x576	50.00	15.625	14.750
576/50p	720x576	50.00	31.250	29.000
720/50p	1280x720	50.00	37.500	75.250
720/60p	1280x720	60.00	45.000	74.250
1080/50i	1920x1080	50.00	28.125/31.250	74.250/72.000
1080/60i	1920x1080	59.94/60.00	33.716/33.750	74.175/74.250
1080/24p	1920x1080	23.98/24.00	26.978/27.000	74.175/74.250
1080/25p	1920x1080	25.000	28.125	74.250
1080/30p	1920x1080	29.97/30.00	33.716/33.750	74.175/74.250
1080/50p	1920x1080	50.00	56.250	148.500
1080/60p	1920x1080	59.94/60.00	67.433/67.500	148.350/148.500

Table 7-2. Supported Signal Timings (continued)

Format	Resolution	Refresh Rate (Hz)	Horizontal Frequency (kHz)	Pixel Frequency (MHz)
SDTV Signals (Video / S-Video)				
NTSC 3.58	–	59.94/60.00	15.734/15.750	3.580
NTSC 4.43	–	59.94/60.00	15.734/15.750	4.430
PAL-B/G	–	50.00	15.625	4.430
PAL-M	–	59.94/60.00	15.734/15.750	3.580
PAL-N	–	50.00	15.625	3.580
PAL-60	–	59.94/60.00	15.734/15.750	4.430
SECAM	–	50.00	15.625	4.250/4.410



Discount-Merchant.com (800) 281-8860
THE TRUSTED SOURCE FOR PROJECTOR LAMPS AND ACCESSORIES

Notes:



Discount-Merchant.com (800) 281-8860
THE TRUSTED SOURCE FOR PROJECTOR LAMPS AND ACCESSORIES

Notes:



Discount-Merchant.com (800) 281-8860
THE TRUSTED SOURCE FOR PROJECTOR LAMPS AND ACCESSORIES



Discount-Merchant.com (800) 281-8860
THE TRUSTED SOURCE FOR PROJECTOR LAMPS AND ACCESSORIES



Discount-Merchant.com (800) 281-8860
THE TRUSTED SOURCE FOR PROJECTOR LAMPS AND ACCESSORIES

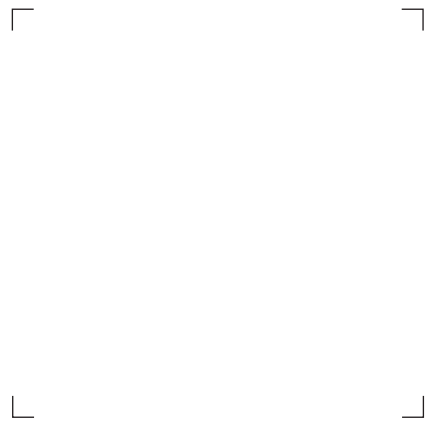

SERIAL NUMBER

020-1009-00 Rev. A
September 2009

Discount-Merchant.com (800) 281-8860
THE TRUSTED SOURCE FOR PROJECTOR LAMPS AND ACCESSORIES



Disclaimer

This user manual is provided as a free service by FixYourDLP.com. FixYourDLP is in no way responsible for the content of this manual, nor do we guarantee its accuracy. FixYourDLP does not make any claim of copyright and all copyrights remain the property of their respective owners.

About FixYourDLP.com

FixYourDLP.com (<http://www.fixyourdpl.com>) is the World's #1 resource for media product news, reviews, do-it-yourself guides, and manuals.

Informational Blog: <http://www.fixyourdpl.com>

Video Guides: <http://www.fixyourdpl.com/guides>

User Forums: <http://www.fixyourdpl.com/forum>

FixYourDLP's Fight Against Counterfeit Lamps:

<http://www.fixyourdpl.com/counterfeits>

Sponsors:

RecycleYourLamp.org – Free lamp recycling services for used lamps:

<http://www.recycleyourlamp.org>

Lamp Research - The trusted 3rd party lamp research company:

<http://www.lampresearch.com>

Discount-Merchant.com – The worlds largest lamp distributor:

<http://www.discount-merchant.com>



FixYourDLP.com

Sponsored by 